

H. HART.
MOTORS.

No. 182,189.

Patented Sept. 12, 1876.

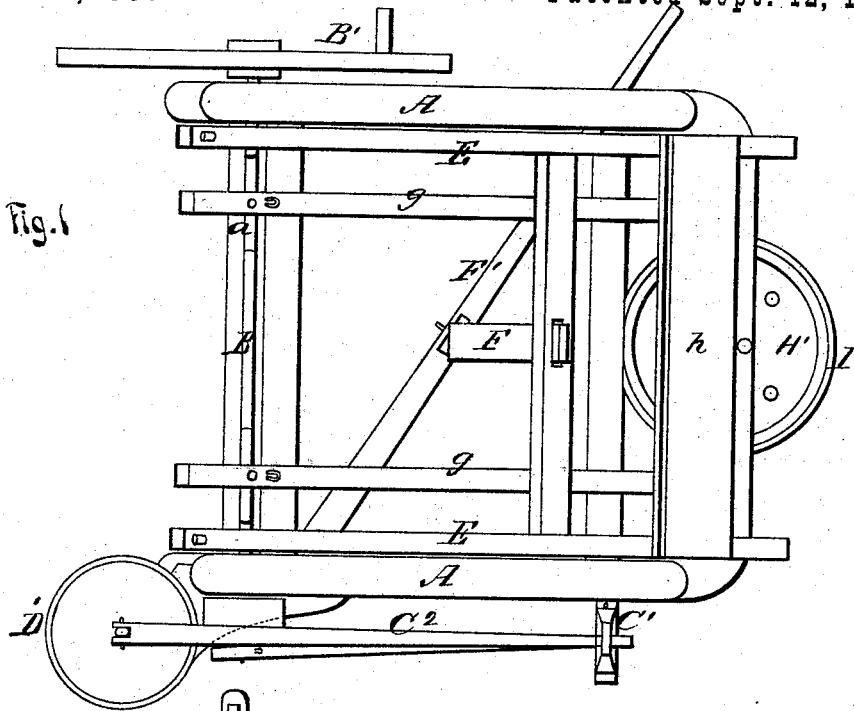

Fig. 1

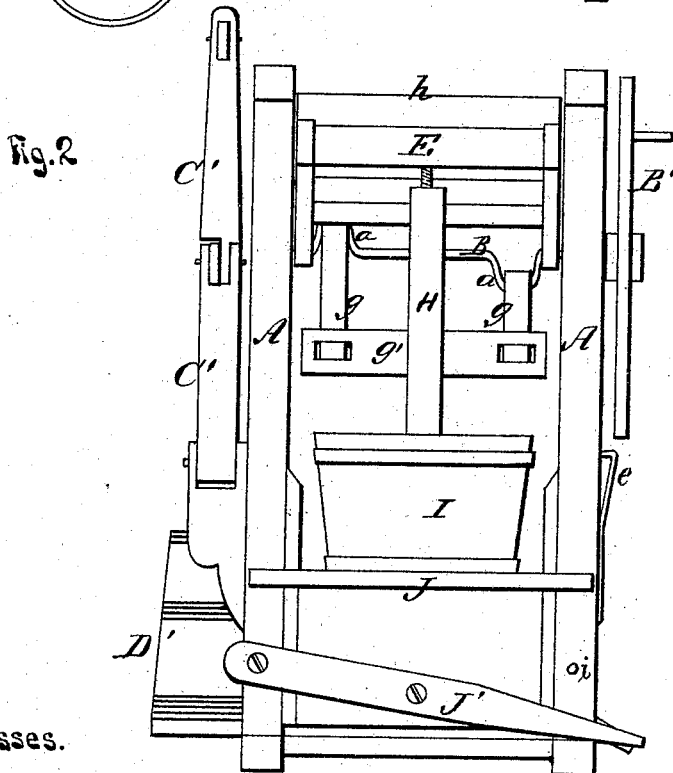

Fig. 2

Witnesses.

George E. Uphauer
Robert Everett.

Inventor.

Henry Hart,
Chipman & Sumner Co.,
Atty.

H. HART.
MOTORS.

No. 182,189.

Patented Sept. 12, 1876.

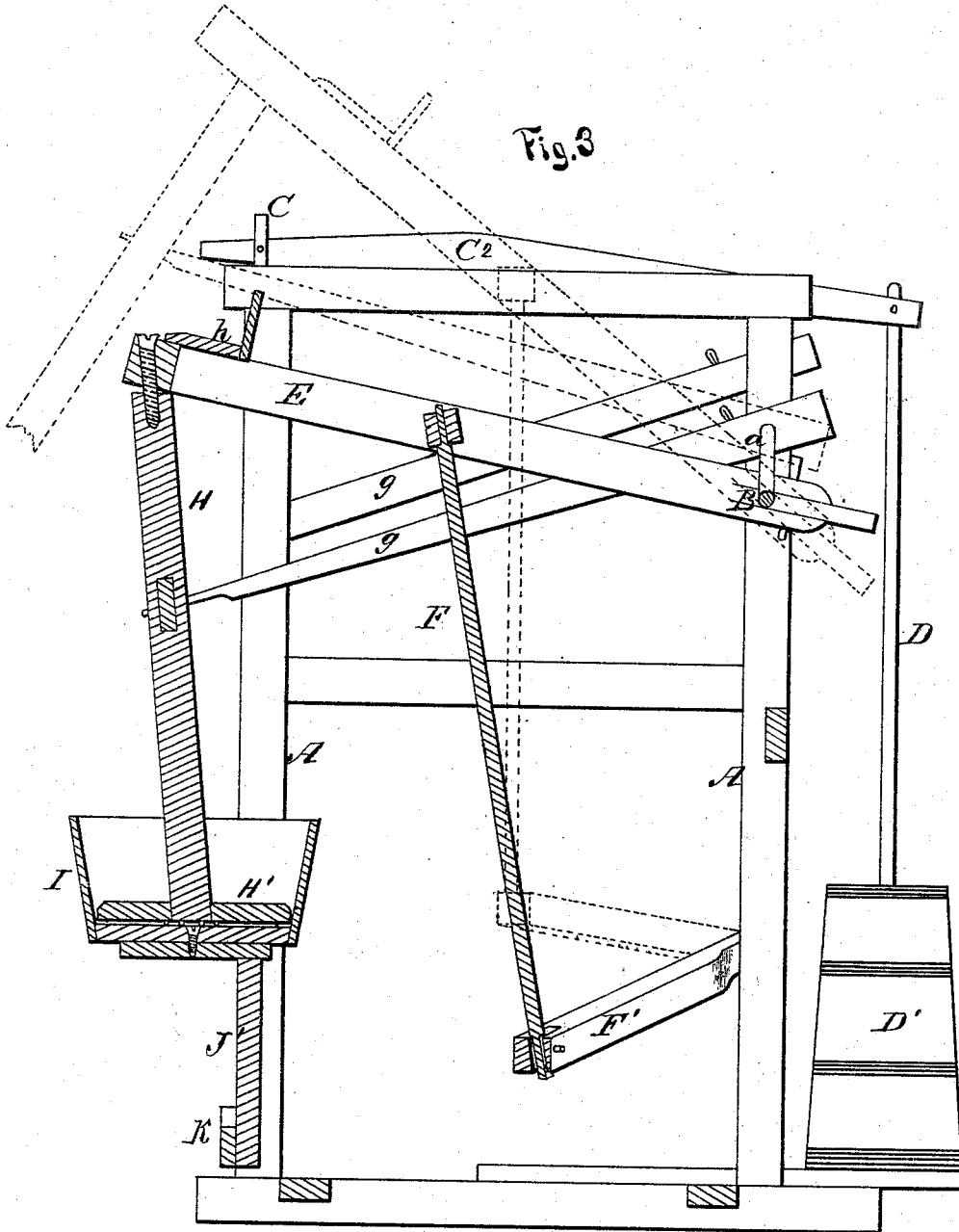

Witnesses.

George C. Upham,
Robert Everett.

Inventor.

Henry Hart
Chipman Fosmer & Co.,
Attys.

H. HART.
MOTORS.

No. 182,189.

Patented Sept. 12, 1876.

Fig. 4

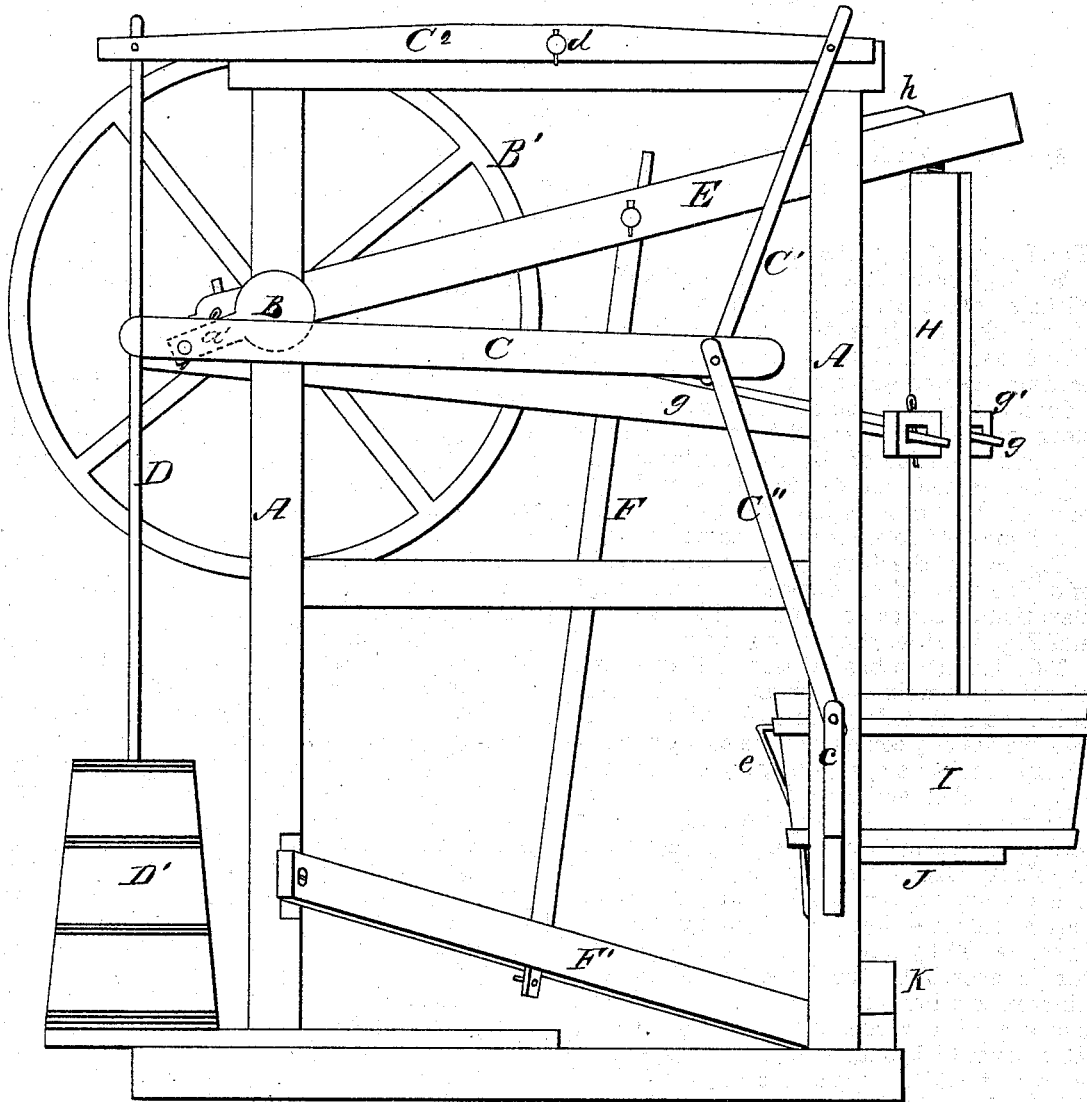

Witnesses.
George E. Upham,
Robert. Everett.

Inventor.
Henry Hart,
Chapman & Co
Attys.

UNITED STATES PATENT OFFICE.

HENRY HART, OF NICHOLS, NEW YORK, ASSIGNOR OF ONE-HALF HIS RIGHT
TO E. N. WATERMAN, OF SAME PLACE.

IMPROVEMENT IN MOTORS.

Specification forming part of Letters Patent No. 182,189, dated September 12, 1876; application filed
January 17, 1874.

To all whom it may concern:

Be it known that I, HENRY HART, of Nichols, in the county of Tioga and State of New York, have invented a new and valuable Improvement in Driving Mechanism for operating washing and churning machines; and I do hereby declare that the following is a full, clear, and exact description of the construction and operation of the same, reference being had to the annexed drawings, making a part of this specification, and to the letters and figures of reference marked thereon.

Figure 1 of the drawings is a representation of a plan view of my device. Fig. 2 is a side elevation of the same. Fig. 3 is a sectional, and Fig. 4 a side, view of the same.

This invention has relation to that class of machines wherein a churn and a washing-machine are operated by the same driving-shaft; and the novelty consists in the construction of certain mechanism, as will be hereinafter more fully described and claimed.

In the annexed drawings, A designates the main supporting-frame, and B the main driving-shaft, which latter is constructed with two bell-cranks, *a a*, and a crank-arm, *a'*, and carries a balance-wheel, B'. The crank-arm *a'* is connected by a rod, C, to the knee-joint of toggle-lever C¹ C¹, the lower one of which is pivoted to a bracket, *c*, and the upper one to one arm of a vertically-vibrating lever, C². This lever C² has its fulcrum *d* on the frame A, and to it the upper end of a dasher-rod, D, of a churn, D', is removably pivoted. E designates a vertically-vibrating frame, which is pivoted on the crank-shaft B, and connected by a vertical rod, F, to a lifting-lever, F'.

This lever F' extends diagonally across the frame A, and when the frame E is lifted, as indicated by dotted lines, Fig. 3, it is held in this position by adjusting the lever F' on a bracket, *e*.

To a cross-bar at the free end of frame E a shaft, H, is pivoted, which shaft carries a circular rubber, H', on its lower end, adapted to work in a wash-tub, I. Shaft H receives oscillation from the cranks *a a* of shaft B by means of connecting-rods *g g* and a cross-arm, *g'*.

The wash-tub I is secured upon a horizontal shelf, J, which is secured to a vertically-adjustable sash, J', that can be raised and depressed by means of a hand-lever, K, and when raised it can be held up by inserting a pin, *i*, into the frame A.

What I claim as new, and desire to secure by Letters Patent, is—

In a driving mechanism for operating a churn and a washing-machine, the rod C, connected to crank-arm *a'* of the crank-shaft B, and to the knee-joint of the toggle-levers C¹ C¹, the upper lever C¹ attached to one end of the vertically-vibrating lever C², in combination with the vertically-vibrating frame E, pivoted to the crank-shaft B, substantially as described.

In testimony that I claim the above I have hereunto subscribed my name in the presence of two witnesses.

HENRY HART.

Witnesses:

A. P. GOTON,
J. O. WATERMAN.