

L. HUNTOON.
COMPOUND STEAM-ENGINE.

No. 182,196.

Patented Sept. 12, 1876.

Fig. 1.

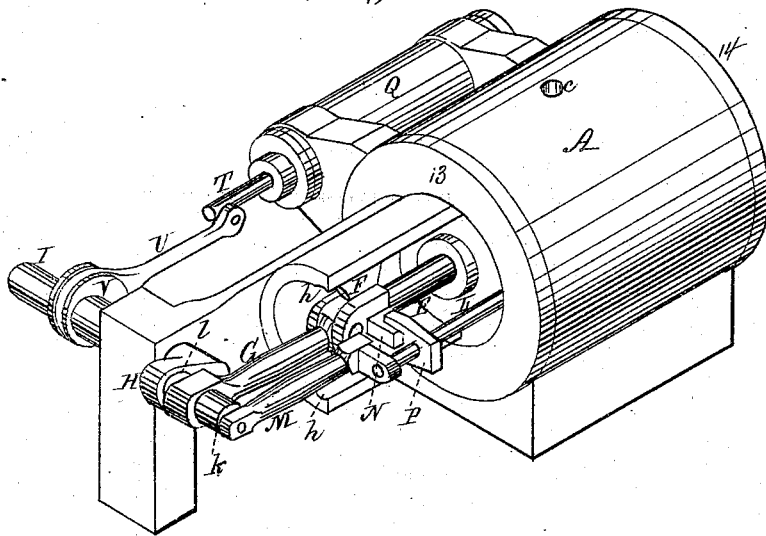
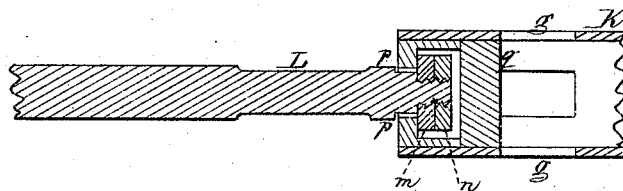

Fig. 5.



Witnesses,
W. J. Cambridge
J. C. Cambridge

Inventor,
Lafayette Huntoon,
Per Tschermacher & Stearns,
Attorneys.

UNITED STATES PATENT OFFICE.

LAFAYETTE HUNTOON, OF NATICK, MASSACHUSETTS.

IMPROVEMENT IN COMPOUND STEAM-ENGINES.

Specification forming part of Letters Patent No. 182,196, dated September 12, 1876; application filed May 10, 1876.

To all whom it may concern:

Be it known that I, LAFAYETTE HUNTOON, of Natick, in the county of Middlesex and State of Massachusetts, have invented certain Improvements in Compound Steam-Engines, of which the following is a full, clear, and exact description, reference being had to the accompanying drawings, making a part of this specification, in which—

Figure 1 is a perspective view of a compound engine constructed in accordance with my invention. Fig. 2 is a horizontal section through the center of the same. Fig. 3 is a transverse vertical section through the same. Fig. 4 is a section on the line *xx* of Fig. 2; Fig. 5, detail, enlarged in section.

My present invention relates to that class of compound engines having an outer cylinder provided with an inner movable piston-cylinder traversing on a stationary piston, the steam first acting between the stationary piston and the inner end of the movable piston-cylinder, and afterward expansively between the outer end of the piston-cylinder and the end of the outer cylinder; and my invention consists in certain details of construction, as hereinafter set forth and specifically claimed.

To enable others skilled in the art to understand and use my invention, I will proceed to describe the manner in which I have carried it out.

In the said drawings, A represents the outer cylinder of a compound steam-engine provided with an inner cylinder, B, which forms its piston, and is denominated the piston-cylinder; the heads *a a'* of which are of the same diameter as the interior of the outer cylinder, and are provided with packing-rings, so as to move therein without leakage of steam. Within the piston-cylinder B is a stationary piston, C, on which it moves, the rod D, which supports the piston C, passing steam-tight through the head of the cylinder B, and being secured to the center of the head of the cylinder A. To the piston-cylinder B is secured the piston-rod E, which passes through the head of the cylinder A, and is attached to the cross-head F, which slides in guides *h*. G is the connecting-rod, secured to the crank H on the driving-shaft I. *c* is an opening in the top of the outer cylinder A, through which steam is ad-

mitted into the annular space *d* between the cylinders A B, in which space the steam is confined between the heads *a a'* of the piston-cylinder. K is a hollow tubular valve, which slides steam-tight through the heads *a a'* and projections *e e* on the inner sides thereof.

The tubular valve K is provided at or near its center with a series of apertures, *f*, which are exposed between the projections *e e* to allow the steam in the annular space *d* to enter the tubular valve K, near each end of which are formed one or more ports, *g*, which communicate with the ports *i i'* of the piston-cylinder B, when the valve K is moved into the desired positions. These ports *i i'* are alternately opened and closed by the sliding of the valve K, the stem L of which passes through the head of the cylinder A, and is jointed at its outer end to a connecting-rod, M, which is pivoted to a crank, *k*, secured to the end of the crank-pin *l* of the crank H, and by the connections above described the tubular valve is made to move simultaneously with and at the same speed as the piston-cylinder during a portion of its stroke; but when it has nearly completed its stroke in either direction the valve K receives a sudden movement independently of the piston-cylinder, whereby the steam is admitted at one end of the piston-cylinder, and at the same time cut off from the other end. On one side of the cross-head F is a projection, N, over which fits a bifurcated slide, P, secured to the stem L of the valve K, a guide being thus formed to support the stem and insure its being moved in a straight line. To allow the valve to have a slight movement independently of its stem, so that it may at all times bear uniformly on its seat in the event of the piston-cylinder having a slight rotary movement, the stem is loosely connected with the valve in the following manner, reference being had to Fig. 5. Through the end of the valve K is formed an aperture for the reception of the end of the stem, of a smaller diameter than the aperture, and secured to the valve by nuts *m n*, a loose connection being thus formed, the stem being provided with a shoulder, *p*, just outside the valve, which is not brought in contact therewith when the nuts are screwed up in place. This shoulder, however, abuts against the valve when it is

pushed by its stem, and the steam is prevented from escaping through the aperture at the joint by a tight head, *g*. In line with each port *i i'*, and within the seat of the valve *K'*, is formed a groove, 16, extending entirely around the valve, which is constantly filled with steam, which exerts a uniform pressure on and serves to balance the valve. *r s* are the exhaust-ports of the outer cylinder *A*, located at each end thereof and communicating with an exhaust-pipe, *Q*, provided with a pair of hollow valves, *R S*, secured to a rod, *T*, which passes out of the exhaust-pipe through a stuffing-box, and is jointed to a rod, *U*, connected with an eccentric, *V*, on the driving-shaft *I*, by which the desired movements are imparted to the valves *R S*, to alternately open and close the exhaust-ports *r s*.

Within the pipe *Q*, in line with the ports *r s*, are formed grooves *t* extending entirely around the valves *R S*, whereby they are balanced by the equal pressure of the steam thereon. *W* is an outlet in the pipe *Q*, for the escape of the exhaust steam.

The parts being in the position seen in Fig. 2, the steam admitted into the annular space *d*, through the opening *c*, enters the valve *K* through the apertures *f*, and thence passes to the port *i*, through the ports *g* adjacent thereto, into the piston-cylinder, between its head *a'* and the stationary piston *C*, whereby the piston-cylinder is made to move through the outer cylinder *A* in the direction of the arrow, the steam in the piston-cylinder on the other side of the piston *C* escaping through the port *i'* and space or opening 12 around the stem *L*, into the outer cylinder *A*, between its head 13 and the head *a* of the piston-cylinder *B*, the steam working expansively, and assisting in driving the piston-cylinder in the direction in which it is already moving, the amount of pressure exerted being in proportion to the difference of the areas of the stationary piston *C* and the outer surface of the head *a* of the piston-cylinder. While the piston-cylinder is moving in the direction of the arrow, the steam between its head *a'* and the head 14 of the outer cylinder *A* is exhausted through the port *s*, into the end of the pipe *Q*, and thence through the hollow valve *S* to the discharge-outlet *W*, the valve being in such position as to leave the port *s* uncovered, the opposite exhaust-port *r* being closed by its valve *R*.

When the piston-cylinder has nearly completed its stroke, the valve *K* commences to move in the opposite direction, cutting off communication between the port *i'* and the opening 12 into the cylinder *A*, simultaneously with which the port *i'* and ports *g* adjacent thereto are brought into line with each other, allowing a fresh supply of steam to enter the

piston-cylinder between its head *a* and the piston *C*, to force the piston-cylinder in the direction contrary to the arrow. This same movement of the valve uncovers the port *i*, and allows the steam first introduced between the piston *C* and head *a'* to pass out of an opening, 15, similar to that 12, into the outer cylinder *A*, between its head 14 and the head *a'* of the piston-cylinder, where it works expansively to assist in forcing the piston-cylinder, as previously described. When the piston-cylinder is moving in this direction, the steam between its head *a* and the head 13 of the outer cylinder *A* is exhausted through the port *r*, into the adjacent end of the pipe *Q*, and thence through the hollow valve *R* to the discharge-outlet *W*, this valve being in a position to leave the port *r* uncovered.

Just before the arrival of the piston-cylinder at the end of its stroke in this direction the valve *K* is again moved, cutting off communication between the opening 15 and port *i*, and at the same time bringing the ports *g* of the valve in line therewith, and also opening communication between the port *i'* and the opening 12, when the parts are brought to their original position, (seen in Fig. 2,) and the operation continues as before.

By admitting the steam into the space between the outer cylinder and piston-cylinder, and locating the valve *K*, exhaust-pipe *Q*, and its valves *R S* in the positions shown, the construction is rendered less complex, the cost reduced, and convenient access afforded for repairs.

The outer end of the crank *k* is so placed that it will travel in the same circle as the end of the main crank *H*, or rather the crank-pin *l*. This arrangement gives the valve the exact motion necessary to open and shut the ports at the required times.

What I claim as my invention, and desire to secure by Letters Patent, is—

1. The sliding tubular valve *K*, with its apertures *f* and ports *g*, placed within the side of the piston-cylinder *B*, in combination with the ports *i i'* and openings 12 15, operating substantially in the manner and for the purpose described.

2. In a compound engine, the valve-crank arranged to travel in the same circle with, and slightly in advance of, the main crank *H*, in combination with the rods *M L*, piston *B*, and guide *N P*, substantially as and for the purpose set forth.

Witness my hand this 2d day of May, A. D. 1876.

LAFAYETTE HUNTOON.

In presence of—

N. W. STEARNS,
P. E. TESCHEMACHER.