

S. S. TIFFANY & G. W. PIKE.  
 BOOT AND SHOE LASTING MACHINE.

No. 182,246.

Patented Sept. 12, 1876.

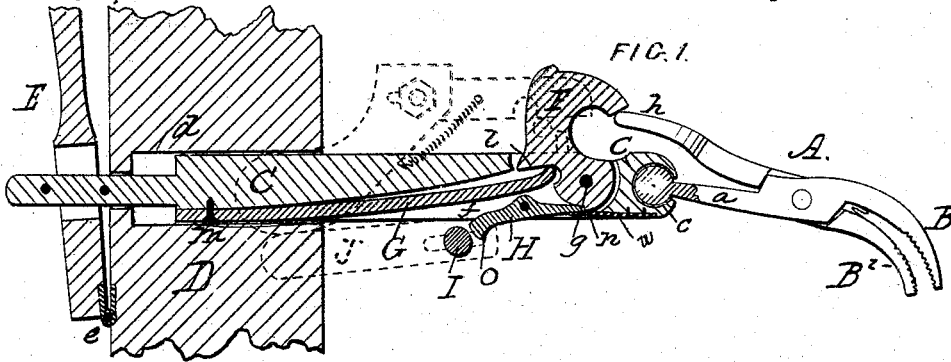

FIG. 2.

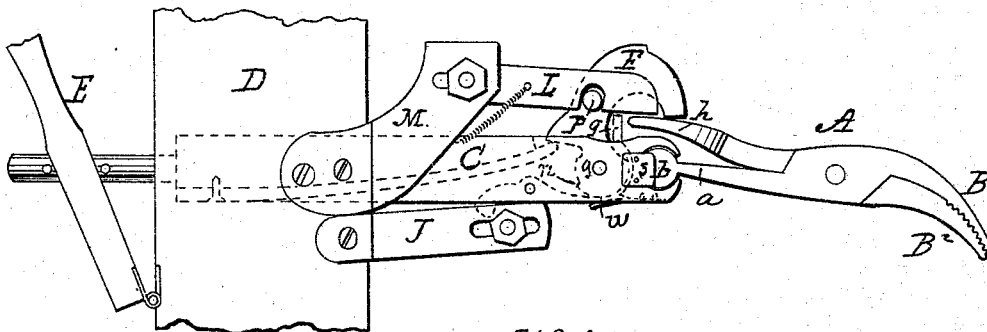

FIG. 4.

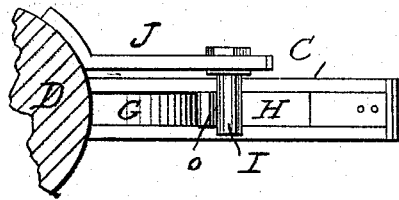
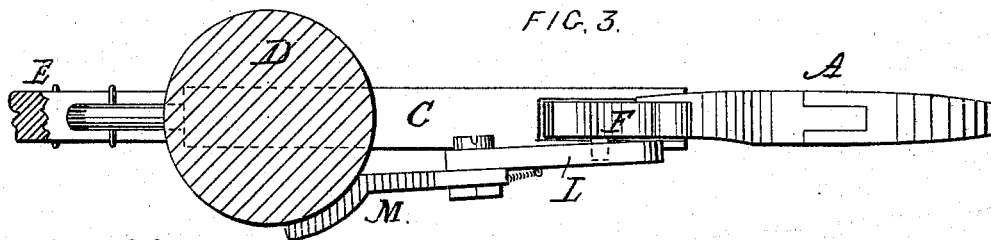

FIG. 3.



WITNESSES.

Geo. H. Carl.  
 E. H. Thon

INVENTORS

S. S. Tiffany.  
 G. W. Pike.  
 Per Baum Bros  
 Attorneys.

# UNITED STATES PATENT OFFICE.

SAMUEL S. TIFFANY, OF NEWARK, NEW JERSEY, AND GEORGE W. PIKE, OF MILFORD, CONNECTICUT.

## IMPROVEMENT IN BOOT AND SHOE LASTING MACHINES.

Specification forming part of Letters Patent No. 182,246, dated September 12, 1876; application filed February 24, 1876.

*To all whom it may concern:*

Be it known that we, SAMUEL S. TIFFANY, of Newark, in the county of Essex, State of New Jersey, and GEORGE W. PIKE, of Milford, county of New Haven, State of Connecticut, have invented certain new and useful Improvements in Machines for Lasting Boots and Shoes, of which the following is a specification:

This invention relates to mechanism for drawing the uppers of a boot or shoe over a last, so that it may be secured to the sole for being afterward stitched or otherwise properly fastened thereto, by hand or machinery; and the invention consists, substantially, of mechanism arranged and operating all substantially as hereinafter described.

In the accompanying plate of drawings, Figure 1 is a vertical section of our invention; Fig. 2, a side elevation; Fig. 3, a plan view, and Fig. 4, a view in detail.

A, in the drawings, represents a pair of spring-pinchers, having gripping-jaws B and B<sup>2</sup>. These pinchers are secured by the extension *a* of one jaw, B, in and to a holder, C, by means of substantially a ball, *b*, and socket, *c*, joint, whereby the pinchers A can have, in the present instance, a vertical swinging motion.

The holder C is arranged and adapted to be moved forward and backward in a slot, *d*, in the standard D, by and through the lever E, to which the holder C is connected, hinged at *e* in the standard, substantially as shown; F, a hammer, hung in slot *f* on a pivot, *g*, of holder, and arranged and adapted to bear upon the extension *h* of jaw B<sup>2</sup> of pinchers A, to close the jaws B and B<sup>2</sup>, when desired, by the spring G bearing against the part of hammer F, the spring G being secured to holder M, as shown.

The hammer F is held in the position shown in Fig. 1 against the spring G by the pawl or trigger H catching in the notch *n* of hammer F.

In the use of the hereinabove-described mechanism, the pinchers are carried forward, and with their jaws open and other parts as shown in Fig. 1, in section and dotted lines, to the last, so that the upper is in and between the two jaws, when, by pulling the lever E backward, carrying with it the holder, trigger,

and pinchers, the trigger H by end O is acted upon, in the said backward movement, by its striking the pin I on arm J of standard D, and thus sets the hammer F free, which, by the spring G is caused to bear upon the extension *h* of jaw B<sup>2</sup>, and thereby close the jaws B and B<sup>2</sup> on the upper, and firmly gripping and nipping it, then is drawn with the pinchers in their continued backward movement until it (the upper) is brought to the edge of the sole of the last, to be there held until properly secured in the usual manner.

When the holder and pinchers are in the position last described, and as is shown in Fig. 2, a spring-catch, L, catches on the pin P of hammer F, as shown in Fig. 2. This spring-catch L serves, on the forward movement of the holder, hammer, pinchers, &c., necessary for a second operation similar to the above, to hold the hammer F, causing it to swing on its pivot *g*, and thereby release its hold upon the pinchers, until, when the forward movement is completed, the trigger H catches by the force of its spring *u* in the notch *n*, and thus holds the hammer up; the spring-catch L then striking the pin *g* on holder, is released from its hold on the hammer, as above described, when all parts are in position and free for a second operation, while at the same time, by a relative movement by hand or by machinery, the last, sole, and upper are presented in another position ready for the seizure at a new point on the upper by the pinchers, and again pulling it over the sole as before, and so on until the work is finished.

The vertical swinging movement of the pinchers, as above described, is requisite to adapt them to the varying width of the sole of the boot or shoe in following the line of the shank, ball of the foot, &c. By the plate S the pinchers are prevented from accidental displacement from their socket, and by taking off the plate S they can be easily removed when desired.

In lieu of connecting the pinchers A to the holder C, in the manner described, they can be connected in any of the obvious forms of hinge or pivot joints, the swinging movement being necessary for the purpose stated.

In the use of the mechanism such as hereinabove described, it can be arranged to operate in connection with any of the so-called lasting-machines, being adapted in connection with a suitable last-carrier, which is arranged to travel so as to bring the edge of the upper, step after step, into the plane of the forward and backward movement of the pinchers, and also in connection with suitable mechanism for each portion of the edge of the upper to be successfully drawn by the pinchers over the last to the sole located on the last; and when so applied, its special operation is to draw the edge of the upper over the last to the sole, and there hold it as it is fastened thereto at such point by the operation of the mechanism last referred to above.

Fig. 4 represents a plan view of the under side of holder and its parts, except pinchers, as represented in Fig. 2.

The spring-catch L and pin I can be adjusted as desired for effective working through the slots in their supports M and J.

Having thus described our invention, what we claim, and desire to secure by Letters Patent, is—

1. In a machine for lasting boots and shoes, the pinchers A, having the jaws B<sup>1</sup> B<sup>2</sup>, and shanks *a* and *b*, the shank *a* having a ball-head, in combination with the socketed holder

C, substantially as and for the object specified.

2. In a machine for lasting boots and shoes, the pinchers A, constructed to have a swinging movement imparted to them, in combination with the sliding holder C, substantially as and for the object specified.

3. In combination with the standard D, the holder C, pinchers A, hammer F, spring G, trigger H, spring *u* and pin I, when all are arranged relatively to each other for operation substantially as described, for the purpose specified.

4. In combination with the standard D, holder C, pinchers A, hammer F, spring G, trigger H, spring *u*, and pin I, the spring-catch L, substantially as and for the object specified.

5. The spring-catch L, in combination with the hammer F, substantially as and for the object specified.

The above specification of our invention signed by us this 8th day of January, A. D. 1876.

SAML. S. TIFFANY.  
GEORGE W. PIKE.

Witnesses:

EDWIN W. BROWN,  
GEO. H. EARL.