

W. A. VANARSDSELL.
SULKY-PLOW.

No. 182,248.

Patented Sept. 12, 1876.

Fig. 1.

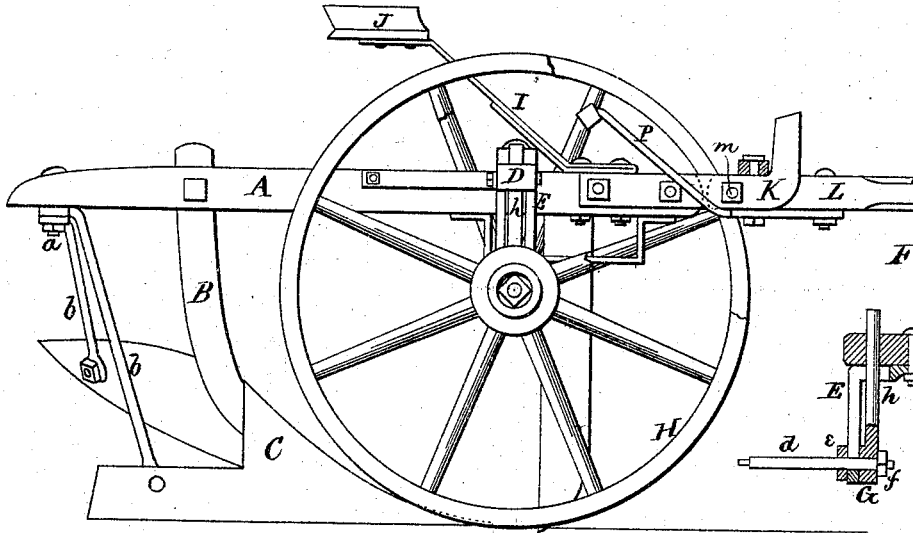

Fig. 3.

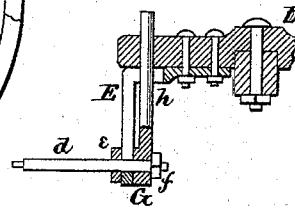
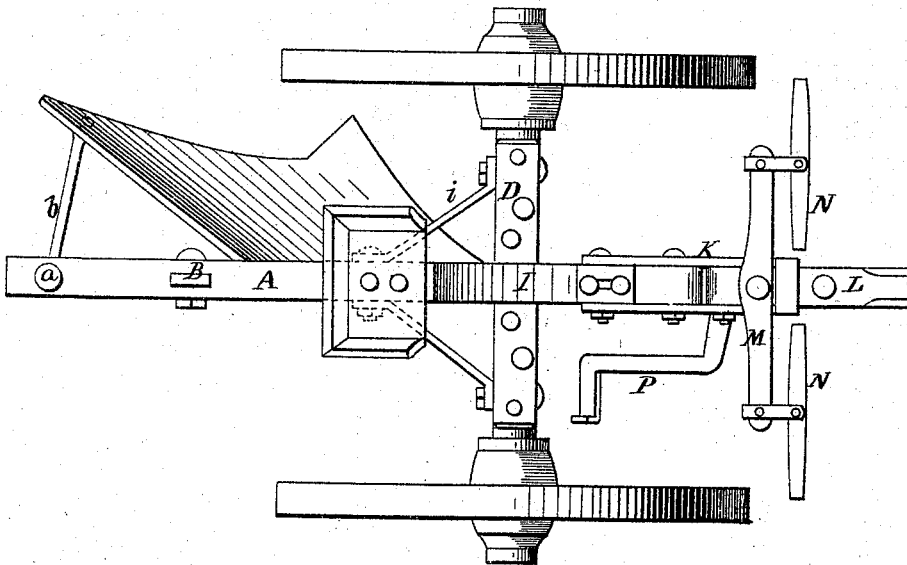

Fig. 2.



WITNESSES

Henry N. Miller
C. L. Ewert.

B11

INVENTOR

Wm. A. Vanarsdell,
Alexander Mator
Attorney.

UNITED STATES PATENT OFFICE.

WILLIAM A. VANARSDPELL, OF McAFEE, KENTUCKY.

IMPROVEMENT IN SULKY-PLOWS.

Specification forming part of Letters Patent No. 182,248, dated September 12, 1876; application filed January 22, 1876.

To all whom it may concern:

Be it known that I, WILLIAM A. VANARSDPELL, of McAfee, in the county of Mercer and in the State of Kentucky, have invented certain new and useful Improvements in Sulky Riding-Plows; and do hereby declare that the following is a full, clear, and exact description thereof, reference being had to the accompanying drawings, and to the letters of reference marked thereon, making a part of this specification.

The nature of my invention consists in the construction and arrangement of a sulky-plow, as will be hereinafter more fully set forth.

In order to enable others skilled in the art to which my invention appertains to make and use the same, I will now proceed to describe its construction and operation, referring to the annexed drawing, in which—

Figure 1 is a side elevation of my plow. Fig. 2 is a plan view of the same. Fig. 3 is a detail view of one of the axles or spindles.

A represents a straight plow-beam, having the plow-standard B secured to it in a mortise. C is an ordinary plow, secured to the standard B, and braced to the beam A by means of braces *b b*, which are fastened to the inner sides of the mold-board and land-side, near their rear ends, and extend up to the rear end of the beam on the under side, where they are fastened by a vertical bolt, *a*, passing through the beam. On the plow-beam A, at any suitable point, is secured a cross-bar, D, forming the axle-tree of the sulky. At each end of the axle-tree on the under side is secured an L-shaped casting, E, which is slotted longitudinally from near the lower end upward and inward beyond the angle thereof. Through this slot is passed the spindle *d*, on which the wheel H is placed. This spindle is provided with a collar or washer, *e*, welded or otherwise permanently attached thereto, which collar comes against the outside of the casting or arm E. The inner end of the spindle

d passes through a box, G, and is fastened by a nut, *f*, on the inner end thereof. From the box G a rod, *h*, extends upward through a hole in the axle-tree D. By these means the wheels H may be adjusted up or down, as required, for regulating the plow. The axle-tree D is braced to the beam A by braces *i i*, as shown. On the beam A is secured an arm, I, which supports the driver's seat J, both said arm and seat being adjustable, so as to be regulated according to the weight of the driver. To the front end of the beam A is secured a bent iron strap, K, having its ends straddling the end of the beam, and fastened thereto by bolts. The center of this bent bar K is turned upward, as shown in Fig. 1, forming, as it were, a loop, in which the tongue L is movable up and down, the rear end of the tongue being pivoted between the sides or ends of the bent straps by a horizontal bolt, *m*, passing through them. On the tongue L, immediately behind the loop, is pivoted the double-tree M, having the single-trees N connected thereto. From the under side of the tongue L at the rear end projects a foot-lever, P, within reach of the driver, by means of which he can at any time raise the plow out of the ground in turning at the end of a furrow and in going to and from the field.

Having thus fully described my invention, what I claim as new, and desire to secure by Letters Patent, is—

The combination of the axle-tree D, slotted L-shaped iron E, wheel-spindle *d*, with collar *e*, box G, with rod *h*, and nut *f*, substantially as and for the purpose herein set forth.

In testimony that I claim the foregoing I have hereunto set my hand this 22d day of October, 1875.

WILLIAM A. VANARSDPELL.

Witnesses:

H. F. JAMES,
W. W. DAVIS.