

W. WEBSTER.  
BAG-SEWING MACHINE.

No. 182,249.

Patented Sept. 12, 1876.

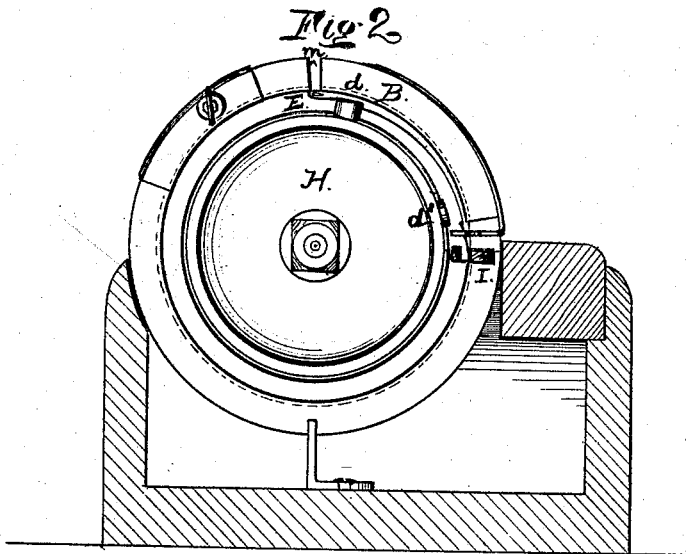
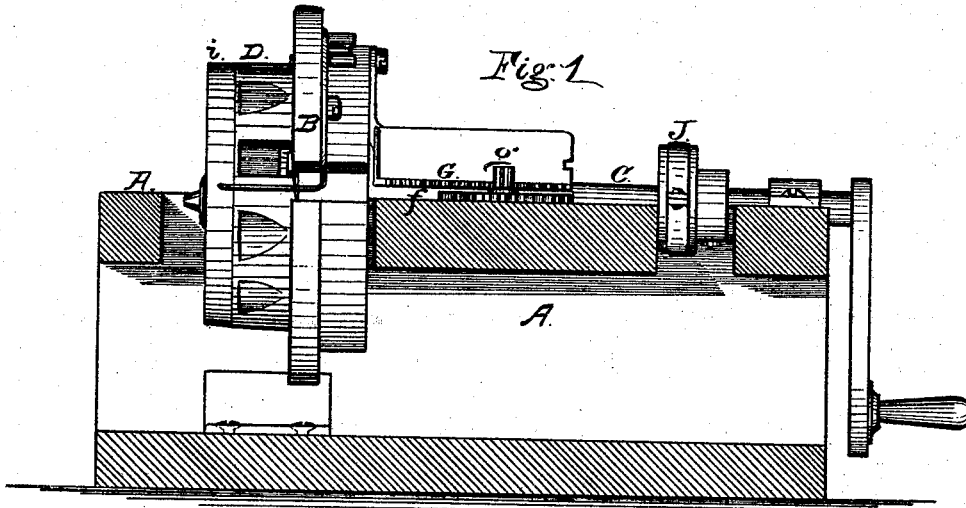

Witnesses:

Edward Osborne  
S. E. Schenk

Inventor:

William Webster  
By G. W. M. Smith  
Atty



W. WEBSTER.  
BAG-SEWING MACHINE.

No. 182,249.

Patented Sept. 12, 1876.

Fig. 4

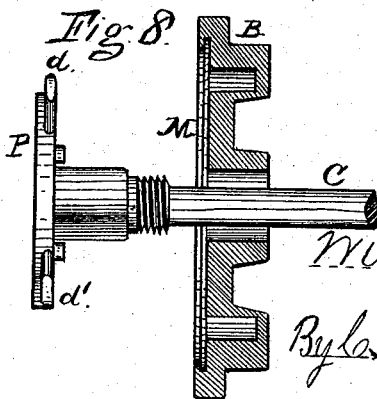
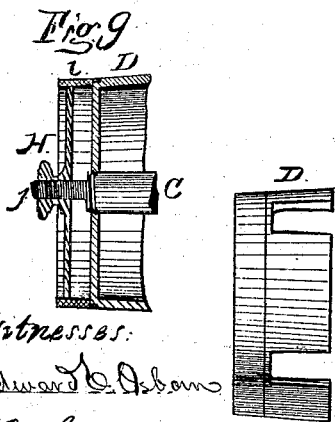
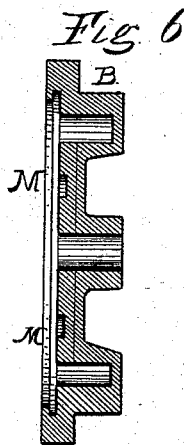
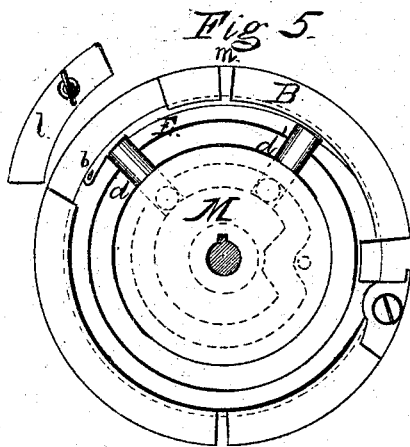
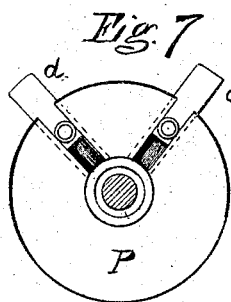
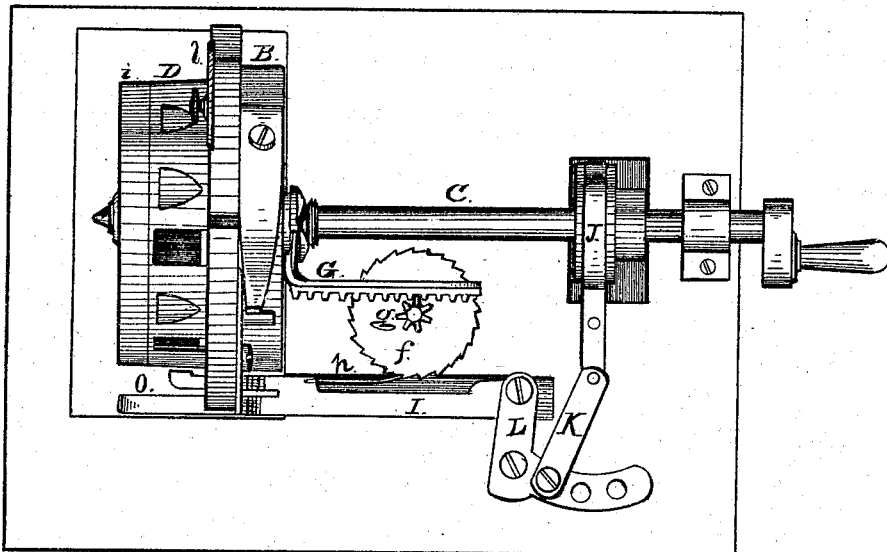

Witnesses:  
Edward D. Adams  
E. C. Schenck

Inventor  
William Webster  
By Wm Smith  
Atty.

# UNITED STATES PATENT OFFICE.

WILLIAM WEBSTER, OF SAN FRANCISCO, CALIFORNIA, ASSIGNOR OF ONE-THIRD HIS RIGHT TO EDINGTON DETRICK, OF SAME PLACE.

## IMPROVEMENT IN BAG-SEWING MACHINES.

Specification forming part of Letters Patent No. 182,249, dated September 12, 1876; application filed January 27, 1876.

### To all whom it may concern:

Be it known that I, WILLIAM WEBSTER, of San Francisco, in the State of California, have invented an Improved Sewing-Machine for Sewing Bags, &c., of which the following is a specification:

My invention relates to that class of sewing-machines used in the manufacture of grain-bags, sacks, and other articles made from coarse material; and it consists in an improved construction and arrangement of parts whereby I produce a machine making an overhand stitch with a single or double thread, and capable of sewing through many thicknesses of coarse material in a perfect manner, and having the capacity to make a strong and tight seam with a coarse thread or twine.

It is the object of my invention to produce these results without tearing the fiber of the material, or making holes in it during the progress of the sewing, and to enable a curved as well as a straight and continuous seam to be sewed, as will be more fully described.

In the accompanying drawings, herein referred to by letters and figures, Figure 1 is a front elevation with the table in section, in order the better to show the arrangement of the mechanism. Fig. 2 is an end view of the same, taken from the left-hand side of Fig. 1. Fig. 3 is a view of the curved needle. Fig. 4 is a top view of my machine, showing the feed mechanism for spacing the stitches and for moving the disk or needle-guide laterally over the thread-take-up cylinder. Fig. 5 is a front view of the needle disk or guide and the needle-driving mechanism. Fig. 6 is a vertical section of the disk and its cam. Fig. 7 is a front view of the needle-driving dogs and their holding-plate. Fig. 8 is a view in detail, showing the arrangement and relation with each other of the take-up cylinder, the needle-driving dogs and plate, and the disk or needle-guide and its cam, the latter being shown in section. Fig. 9 is a view in section of the end of the take-up cylinder, showing the tension-band and mechanism for regulating the same.

The principal elements of this machine are: a circular disk with an inner groove or track for the needle, a curved needle formed on the arc of a circle of the same curve as the groove,

and with two shoulders and an eye at the head, an arrangement of mechanism for giving a continuous rotary motion to the needle within the circular groove of the disk, and a conical revolving thread-take-up for throwing off the proper amount for each stitch, and taking up the slack of the thread as the sewing progresses. These parts are arranged with proper driving and feeding mechanism to produce a working machine.

A is the bed or table of the machine; B, the circular grooved disk, having a sliding horizontal motion upon the shaft C, but not revolving with it; D, the revolving conical take-up fixed on the shaft C; and *d d'* are the two arms or dogs that engage with the notches or shoulders of the needle E, and give to it a continuous rotary motion within the groove *b*. These arms are operated from a face-cam that forms a part of the needle-disk B within the conical take-up, whereby one arm at a time is drawn from the shoulders of the needle to allow it to pass through the material and thrown out again in contact with the needle after the shoulder has passed through and below the fabric, so that while the needle is free to carry its thread through the material it is always in contact with, and is driven by, one of the arms or dogs, and from the form of the cam the arms are withdrawn from the needle only while that shoulder engaged by the arm is passing through the material. These arms or dogs *d d'* work through slots in the conical take-up D, and they give a positive continuous rotary motion to the needle. The form of the needle E and the manner of holding it within the groove in the disk B, and of driving it with a positive motion, renders it capable of sewing through many thicknesses of the coarsest and heaviest material that is used in the manufacture of grain-bags, sacks, and other articles.

The thread or twine *e* is secured to the end of the needle E, which, as it revolves, carries the thread through the material so that the thread lies in a succession of loops around the conical drum D, and embracing said conical drum and that portion of the material between the edge and the puncture made by the needle, and the progression of the material

produced by the feed mechanism causes the coils of thread to move gradually upon the conical surface toward the smaller end of the drum so that these loops may be pulled off and drawn up one at a time into the material and over its edges to produce the overhand stitch. But as one of these loops is more than sufficient for one stitch, the remainder is pulled up and taken again upon the drum as it revolves, and before another loop is cast off by the strain or pull upon the thread by the needle. Thus a loop is cast off and pulled up for each revolution of the drum D and the needle in the disk B, and as one part of the thread is secured to the material that is being moved away by the feed while its end is attached to the needle, there is produced a constant strain or pull upon the thread that serves to draw up the loops.

The action of the feed in moving the material causes the coils of thread upon the drum D to move toward the smaller end and away from the needle-disk B, so that the thread would extend diagonally after a time, from the last coil to the eye of the needle, unless some means were provided whereby the thread and the needle could be kept nearly in the same plane, and thus enter the cloth more easily and with no side pull or strain upon the needle. For this purpose I cause the needle-carrying disk B to have a longitudinal sliding movement toward the smaller end of the drum D to correspond with the motion of the coils of thread, and thus I keep the last coil or end of the thread and the needle always in about the same straight line. In addition to this sliding movement of the disk B, I give a rotary motion to the conical drum D, to reduce the strain upon the thread; for, if the take-up drum D were stationary, and the needle, with its disk, had no sliding movement, but only a motion of rotation, the thread that is carried around by the needle would not be laid in even coils one after the other, and the friction between the thread-coils and the surface of the conical drum D would soon become so great that neither the thread nor the needle could withstand the strain thus thrown upon them, and a perfect seam could not be made.

From this construction it will be seen that the circular motion of the needle produces in connection with the progression of the material, a constant pull upon the thread, while the sliding movement of the disk B and the rotary motion of the conical drum D, operate to reduce the friction upon the thread and cause its coils to be laid evenly upon the drum and the needle, and the last coil to be kept nearly in a straight line, as the coils move toward the smaller end of the drum.

The sliding movement of the disk B is produced by the rack G secured to the disk, and the pinion *g* upon the ratchet-wheel *f*, and the necessary rotation of this wheel is produced by a finger, *h*, on the feed-bar, as shown in Fig. 4.

When the disk B has reached the limit of its motion toward the end of the drum D, and the thread is all exhausted, the rack is sprung away from contact with its pinion *g*, and the disk is drawn back to its first position, and a fresh supply of thread provided for another start.

In a machine of twice the size shown in the drawings, the needle will make seventy revolutions and produce as many stitches while the disk is moving from one end to the other of the conical drum.

The take-up drum D is made conical in order to allow the thread to move down gradually toward the elastic end, and to facilitate the discharge of the loops or coils, and the head of the drum or cylinder is provided with an elastic surface or band, *i*, to act as a tension upon the loop of thread, that it may be drawn off by the pull or strain upon it by the movement of the material in feeding instead of dropping off loosely and falling down in the way of the sewing mechanism. This elastic band *i* has a plate, H, within the head of the take-up drum, adjustable on the shaft C, by means of the set-screw *j*, as shown in Fig. 9, so that the rim of the band *i* may be raised and spread out more or less to act upon the loop of thread and retard its motion in dropping or being drawn off the cone to a greater or less degree, and thus the tension of the thread at this point is increased or diminished.

The feed mechanism consists of the serrated bar I that reciprocates back and forth beneath the presser-foot. The movement is given to this bar by means of the eccentric J on the main shaft C, through the medium of the link K and lever L, as shown in Fig. 4. The revolution of the eccentric J produces a rocking motion of the lever L, that is pivoted to the table, and this a reciprocating movement to the bar I that is connected with the lever by means of the link K. One arm of the lever L is made of curved shape, so that the connection or bar secured to the strap of the eccentric J may be set nearer to, or farther from, the center of motion or pivot of the lever L, and its extent of motion and the motion of the bar I are thus graduated at pleasure.

This form of feed mechanism may be varied, however, in the construction of my machine, and I do not confine myself to the form herein described and shown, as many forms of four-motion feed may be substituted for it.

The disk B has a presser-foot, O, and a movable plate, *l*, in the side of the flange to permit the needle to be removed and replaced when necessary. It has, also, a notch, *m*, extending down to the groove or track of the needle to facilitate the introduction of the thread into the eye of the needle.

The needle-driving mechanism is shown in detail in Figs. 5, 6, 7.

The form of the cam M is such that the first dog *d* is withdrawn from the shoulder at the point of the needle as it reaches the cloth, and is thrown out again to engage with the

shoulder after it has passed through the material, and the second dog *d'* is operated in the same manner as it passes the cloth, one of the dogs being at all times in contact with the needle and the motion produced by them being a positive one.

The face-cam M that drives the dogs is stationary, and forms a part of the needle-guiding disk B. The form of its groove is shown in Figs. 5 and 6. The dogs are held in place against this cam and rotated by the face-plate P, each dog being provided with a pin and roller, and moving up and down in the groove in the face-plate that is fixed upon the driving-shaft. This arrangement of mechanism is shown in Fig. 7.

The form of the needle and the manner of driving it make a strong sewing mechanism capable of penetrating the strongest material and of uniting many thicknesses of it together. This machine has also the capacity to sew a continuous seam around corners, and make curved as well as straight lines of sewing, and from the principle of its construction it will be seen that it can be run at a rapid rate of speed and still make a perfect seam.

The conical take-up holds the thread as it is laid by the needle in a compact manner out of the way of the sewing mechanism, and prevents any entanglement or snarling of the thread. In the machine of the size shown in the drawings, the take-up will carry thread enough to sew seventy stitches; but the size of the machine can be increased to sew twelve or more sacks before it would be necessary to move back the disk B on the shaft toward the head of the take-up cylinder. The curved needle E is shown with the shoulders or notches *d d'* for driving it made on the under surface; but I do not confine myself to the precise form or position of them, as they may be placed at the side of the shank and made of a wedge shape.

Having thus fully described my invention, what I claim as new, and desire to secure by Letters Patent, is—

1. A sewing machine or mechanism, composed of the following elements, viz: A circular disk or needle-guide, B, having a groove or track for the needle; a curved needle, E, formed

on the arc of a circle that coincides with the groove or track of the disk; a needle-driving mechanism consisting of a cam, M, cam-plate P, and dogs or arms *d d'*, or equivalents for giving to the needle a continuous rotary motion within the groove in a forward direction; and a cylindrical take-up, D, formed with a conical surface, and arranged to revolve continuously in the same direction as the needle, when these parts are arranged and combined with proper feeding, driving, and thread-controlling mechanism, as described and set forth.

2. In a sewing machine or mechanism, the circular needle holding and guiding disk B, with a groove or track for the needle, the axis of which coincides with the center of the disk, combined with mechanism to move it in a horizontal direction upon its axis or shaft over and upon the conical take-up D, but having no rotary motion, constructed as and for the purpose described and set forth.

3. In a sewing machine or mechanism, the combination with the needle E, herein described, of the revolving cam M, cam-plate P, and dogs *d d'*, or equivalent mechanism for driving and propelling the needle continuously forward in a rotary path; in the manner and for the purpose described and shown.

4. In a sewing machine or mechanism, the combination, with the needle E, and its propelling mechanism herein described, of a revolving conical thread cast-off and take-up D, arranged within the circle traversed by the needle, and having a continuous rotary motion in the same direction as the motion of the needle, in the manner and for the purpose described.

5. In a sewing machine or mechanism, the elastic tension-band *i*, and its adjusting-plate H, or equivalent, arranged and combined with the conical revolving take-up D, to control the loops of thread in the manner described and shown.

In witness whereof I have hereunto set my hand and seal.

WILLIAM WEBSTER. [L. S.]

Witnesses:

C. W. M. SMITH,  
PHILIP MAHLER.