

J. S. STEWART.
 BARREL-FILLING MACHINE.

No. 182,336.

Patented Sept. 19, 1876.

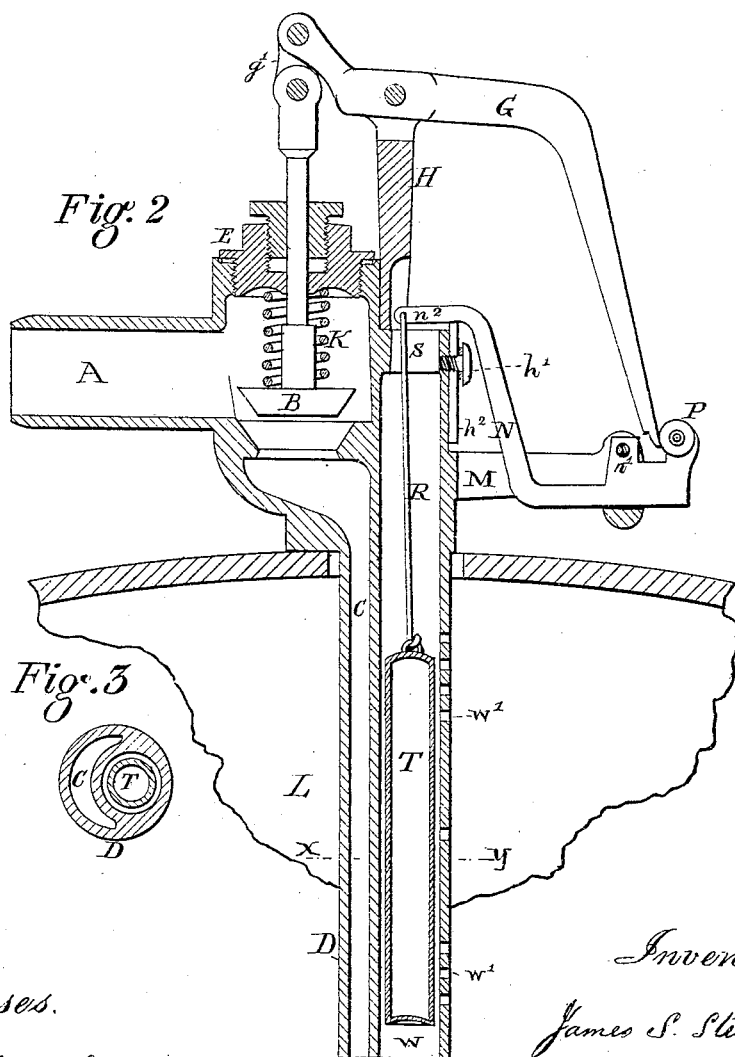
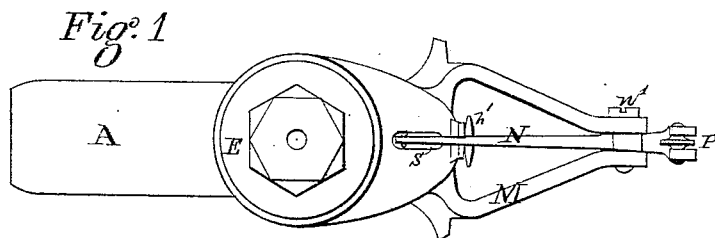

Witnesses.

D. Louis Shivers
 John S. Grant.

Inventor.

James S. Stewart
 per Edw. Brown
 attorney.

UNITED STATES PATENT OFFICE.

JAMES S. STEWART, OF PHILADELPHIA, PENNSYLVANIA.

IMPROVEMENT IN BARREL-FILLING MACHINES.

Specification forming part of Letters Patent No. 182,336, dated September 19, 1876; application filed June 3, 1876.

To all whom it may concern:

Be it known that I, JAMES S. STEWART, of Philadelphia, in the county of Philadelphia and State of Pennsylvania, have invented a new and useful Improvement in Machines for Filling Barrels, which improvement is fully set forth in the following specification, reference being had to the accompanying drawings, in which—

Figure 1 is a plan with the tripping-lever removed. Fig. 2 is a vertical section through the machine. Fig. 3 is a section on the line X Y.

The machine may be briefly described as a cock with a drop-valve to cut off the supply as soon as the barrel is full.

My improvement relates to the arrangement and combination of the lever, trigger, and float which operates the valve.

The cock is cast in the form of an elbow. The pipe A conducts the oil from the tanks through the drop-valve B, and down the passage C in the spigot D into the barrel L. The spigot D fits loosely in the bung-hole of the barrel, and permits the escape of air outside. The stem of the valve B passes through the stuffing-box E, and is connected, by a short link, g' , to the lever G, the latter being pivoted upon the support H. A spring, K, between the valve and stuffing-box, closes the valve as soon as the lever is released, as explained further on. A bracket, M, is cast upon the barrel-filler, to which the trigger N is hinged at n^1 . The outer and short arm of the trigger carries a wheel, P, turning easily upon a center-pin. The other end, n^2 , passes upward like a bell-crank, and over the top of the tube W, where it is connected, by a link, R, passing through the slot S, to the copper float T. This float slides freely in the tube W, which tube has a few holes, w' , to permit the oil to enter and escape freely from it. An adjusting-screw, h^1 , is for raising or lowering the scale h^2 .

The lowering of this scale depresses the arm n^2 and the float T, thereby filling the barrel fuller than when the float T is in its highest position. By this adjustment the quantity of oil let into the barrel may be regulated with great accuracy.

The operation of the machine is in this manner: The spigot D is inserted in the bung-hole of the barrel. In this position the weight of the float brings the arm n^2 in contact with the scale h^2 . The lever G is pressed down so that its point catches beneath the trigger-wheel P. This raises the valve B, and permits the oil to enter the barrel until it raises the float T, thereby liberating the arm G, and the spring K closes the valve and prevents any further entrance of the liquid.

The wheel P upon the end of the trigger N retains the lever G firmly in position, and yet the friction required to release it is so slight that the quantity of oil introduced can be regulated with great accuracy, whatever may be the pressure from the head of oil in the supply-tanks.

The wheel P may be dispensed with, and only the lever G and trigger N used, but the machine is not so efficient or useful as with it.

I claim—

1. In a barrel-filler, the tripping-lever G, pivoted upon the arm H, and operating the valve-stem through the stuffing-box E, in combination with the trigger N, the link R, and float T, substantially as herein described.
2. In a barrel-filler, the trigger N, in combination with the wheel P, for the purpose of liberating the valve-arm, as described.
3. In a barrel-filler, the combination of the adjustable scale h^2 , the trigger N, link R, and float T, substantially as described.

JAS. S. STEWART.

Witnesses:

EDWD. BROWN,
JOHN F. GRANT.