

W. WOOD.

MACHINES FOR TESTING PIPE.

No. 182,397.

Patented Sept. 19, 1876.

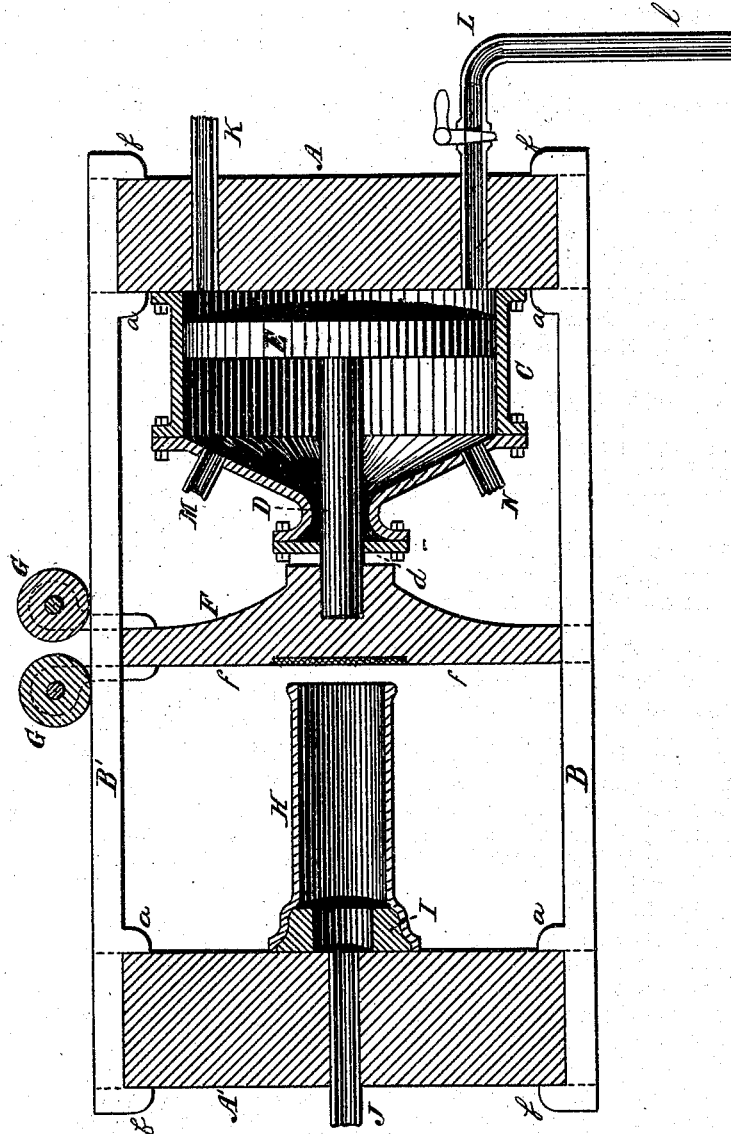

Witnesses
A. P. Wright
W. C. Strawbridge
By

Inventor
Walter Wood
George Harding
Attorney

UNITED STATES PATENT OFFICE.

WALTER WOOD, OF PHILADELPHIA, PENNSYLVANIA.

IMPROVEMENT IN MACHINES FOR TESTING PIPES.

Specification forming part of Letters Patent No. 182,397, dated September 19, 1876; application filed August 3, 1876.

To all whom it may concern:

Be it known that I, WALTER WOOD, of the city of Philadelphia, and State of Pennsylvania, have invented a new and useful Machine for Testing the Strength of Water, Gas, and other Pipes, of which the following is a specification:

The drawing represents a central longitudinal section of my machine.

The nature of my invention consists in the combination and arrangement of such devices as will, in a hydrostatic machine for testing the strength of metallic pipes, instantly and effectively open and close the ordinarily open ends of such pipes, leaving, however, a suitable aperture for the injection of the testing-fluid.

The construction of these devices is as follows: A suitable frame is formed by rigidly connecting together the heavy ends or disks A A' by means of the tie-rods B B', these rods being sunk or let into the upper and lower parts of the disks A A', and being provided with shoulders *a b*, which prevent any lateral displacement of the disks. Upon the inner surface of the disk A is formed a cylinder, C, provided with a piston-rod, D, working through a suitable bearing, *d*, in the inner end of the cylinder, and carrying upon its outer end a solid piston-rod head, E. The piston-rod is attached at its inner end to a plate or disk, F, having its outer face *f* smoothly and evenly finished. This disk, in addition to being connected with the rod D, is hung from or suspended by means of pulleys G traveling upon the upper tie-rod B', which forms a rail for the same. H represents the pipe to be tested, and I a projecting collar formed upon the inner side of the disk A', for the partial support of the pipe, and to direct it into proper position while being adjusted in the machine. J is the pipe or opening through which the testing-fluid is introduced to the pipe. K is a pipe through which water is introduced to the cylinder to operate the machine, and L the escape for the same. M is an opening through which water may be introduced to the cylinder, to drive the piston backward, and N the escape for the same.

Such being the construction of my device,

its mode of operation is as follows: The pipe H is suitably supported in any convenient manner in the position shown in the drawing. The valves L, M, and N being closed, the valve K is opened, and water under pressure is introduced to the cylinder. The piston-rod and its disk F are instantly forced hard against the open end of the pipe H. A rubber or other suitable gasket, having previously, if necessary, being fitted to the disk, water under pressure is then introduced through the valve J to the pipe H in the ordinary manner. The operation having been completed sufficiently, the valves J and K are closed, and the valve L opened, the valve N being shut. Water is introduced to the inner side of the piston-head through the valve M, and thus the disk F is freed from contact with the pipe, the valves L and N serving to empty the cylinder of water at the proper time.

I have found it advantageous to construct the pipe L of considerable length, as shown in the drawing, by means of which the cylinder can be more quickly emptied of water, and in certain sizes of the machine, the vacuum so formed by the rapid discharge of the water will of itself be sufficient to withdraw the piston to the outer end of the cylinder without the necessity of water being introduced through the valve M.

The advantages of my improvement are apparent. The pressure can be applied instantly, and to such an extent as to avoid leakage due to imperfect stoppage of the pipe, as is incident to the ordinary plan of bringing a disk into contact with the pipe by means of a screw and the like.

I do not limit myself to the exact form or arrangement of devices shown in the drawing, it being readily seen that a variety of arrangements embodying the same invention can be made.

Having thus described my invention, I claim—

1. In a machine for testing the strength of pipes, a disk, F, actuated by hydrostatic pressure, substantially as shown and described, and for the purpose specified.

2. In a machine for testing the strength of pipes, the combination of the disk F, the cyl-

inder C, piston-rod D, and piston-rod head E, substantially as shown and described, and for the purposes set forth.

3. The piston-rod D, head E, and disk F, in combination with the cylinder C, having valves K, L, M, and N, one of which, L, is provided with a pipe, I, substantially as shown and described, and for the purposes specified.

4. The combination of the pipe H, the disk A', disk F, piston-rod D, piston-head E, and cylinder C, substantially as shown and described, and for the purposes specified.

WALTER WOOD.

Witnesses:

NATHL. B. CRENSHAW,
J. T. BEYARD.