

A. MOORE.  
BORING-MACHINE.

No. 182,463.

Patented Sept. 19, 1876.

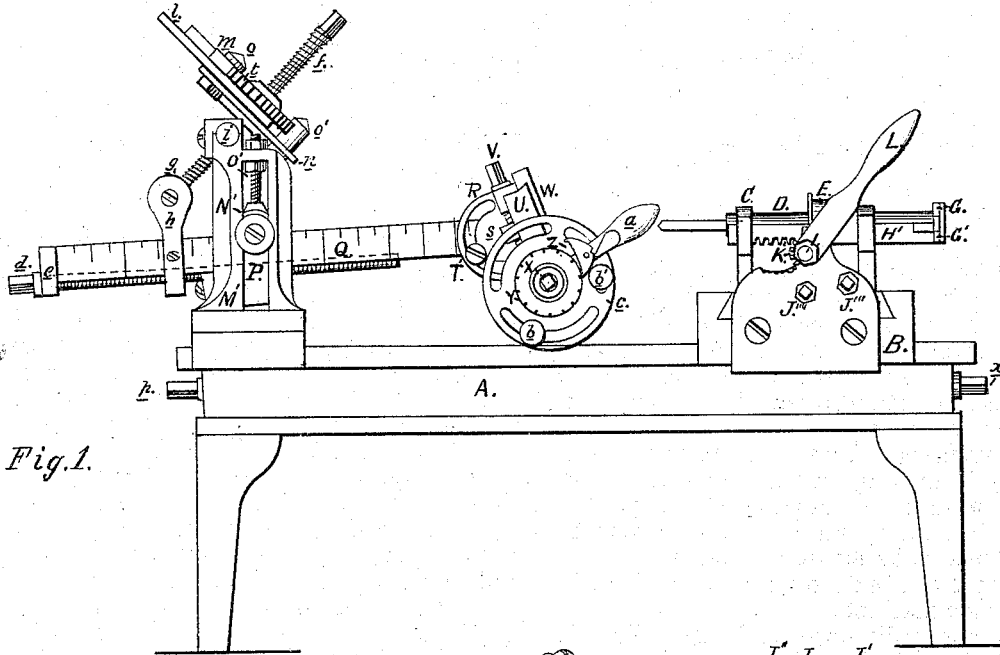

Fig. 1.

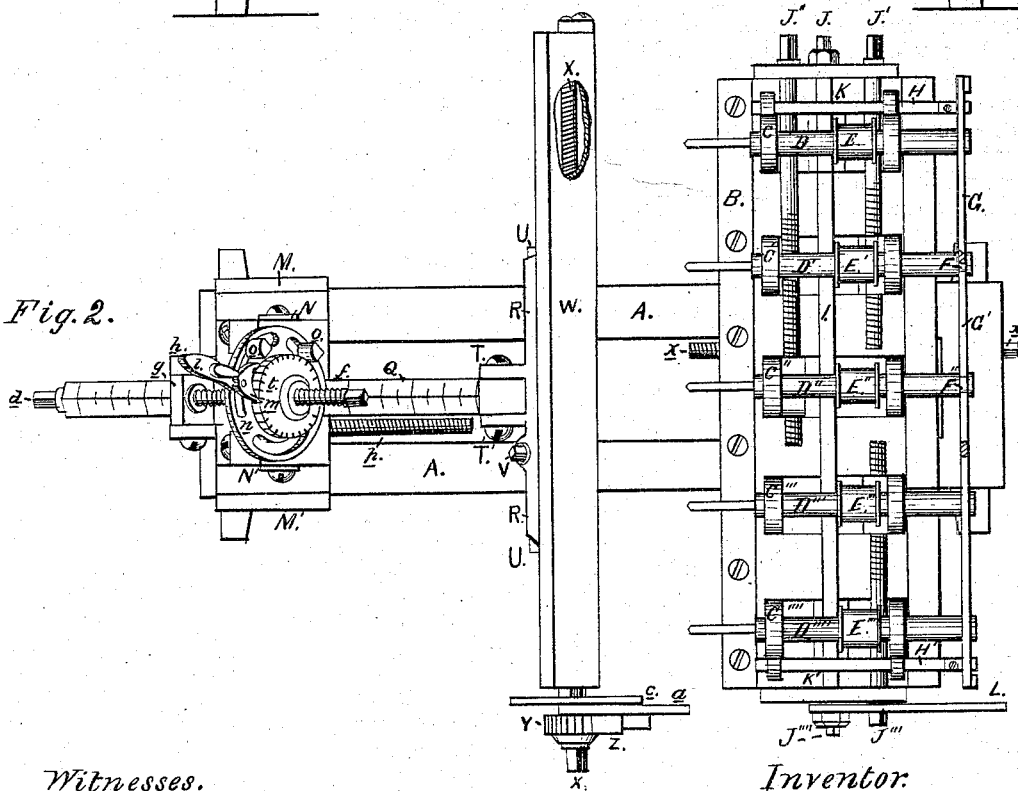

Fig. 2.

Witnesses.  
Albert M. Moore.  
Samuel B. Wyman

Inventor:  
Archibald Moore.

# UNITED STATES PATENT OFFICE.

ARCHIBALD MOORE, OF LOWELL, MASSACHUSETTS, ASSIGNOR TO SAMUEL E. STOTT, OF SAME PLACE.

## IMPROVEMENT IN BORING-MACHINES.

Specification forming part of Letters Patent No. **182,463**, dated September 19, 1876; application filed May 1, 1876.

*To all whom it may concern:*

Be it known that I, ARCHIBALD MOORE, of Lowell, in the county of Middlesex and Commonwealth of Massachusetts, have invented an Improvement in Boring-Machines, which improvement is fully set forth in the following specification, reference being had to the accompanying drawings.

My invention relates to the means of operating and adjusting the head-stock, drills, tail-stock, and face-plate of a machine for drilling wooden lags for cylinders; and consists in the improvements hereinafter described.

Figure 1 is a side elevation, and Fig. 2 a plan, of my machine.

Upon a metallic head, A, is dovetailed the head-stock B. This head-stock is rectangular, and has dovetailed onto it the separate head-stocks or drill-arbor bearings C C' C'' C''' C''', which support the drill-arbors D D' D'' D''' D'''. The drill-arbors are revolved by quarter-turn belts, which run from a wide pulley above them around the flanged pulleys E E' E'' E''' E''', secured on said arbors. Said drill-arbors have each an annular groove, F F' F'' F''' F''', at their outer ends, into which are laid the parallel bars G G', secured together at their ends. Rack-bars H H', running through holes in the outer drill-bearings D D''', are also grooved to receive the bars G G'.

The rod I, running from end to end of the head-stock B, has splined to it two pinions, K K', which take into the bars H H'. By turning the lever L, attached to the rod I, the drill-arbors are simultaneously carried to or from the work. The distances of the drill-arbors from each other are regulated by the screws J J' J'' J''' J'''. The head-stock is moved toward or from the tail-stock by the screw *a*.

The tail-stock is also dovetailed onto the bed A, and consists in a base, upon which are two uprights, slotted vertically, M M'. In the slots in said uprights are vertically-adjustable boxes N N', (raised or lowered by the screws O O',) in which swings the yoke P. The yoke P sustains a graduated arm, Q, to which is pivoted the head R. The head R is kept from turning by the set-screws T T'.

A plate, U, is dovetailed over the flat part

of the head R, so that the former may slide vertically on the latter when moved by a screw, V, which runs through a nut on the head R and a post on said plate U. A face-plate, W, is so dovetailed onto the plate U that it may be moved sidewise by a nut on the plate U and a screw, X, attached to said face-plate by suitable bearings.

On the end of the screw X is a circular ratchet, Y, operated by a pawl, Z, on the lever *a*, the amount of motion of said lever being determined by the adjustable stops *b b'* on the stop-plate *c*. These stops are secured by nuts on the under side of the stop-plate.

The head R and face-plate W on the arm Q may be brought nearer the tail-stock by the screw *d*, which runs in a nut in the yoke P, and is supported by the bearing *e* on said arm. Angular motion is imparted to said arm by the tangent screw *f*, the head of which is secured to a swivel, *g*, in the carrier *h*. From the carrier the screw passes through another swivel, *i*, between the uprights M M'. A circular ratchet is splined to the screw *f*, and a lever, *l*, and pawl *m* serve to rotate the screw. A stop-plate, *n*, attached to the swivel, and stops *o o'* are similar to those on the face-plate W, and serve a similar purpose. The tail-stock is moved toward or from the head-stock by the screw *p*.

It will be seen from the above description that the adjustability of the face-plate W on the center enables holes to be drilled at any bevel—that is, at any angle to a tangent of the cylinder formed by the lags; that said face-plate, by means of the graduated arm Q, may be set at a distance from the center equal to the radius of curvature on the face of the lag; that the face-plate, by means of the screw X and ratchet Y, may be so adjusted endwise (or sidewise) as to drill the holes which form a single row; and that the amount of this endwise adjustment may be determined by the position of the adjustable stops *b b'*; that the vertically-adjustable centers N N' of the radius enable the lag to be so placed that, whatever the bevel, the drills will be in the same horizontal plane with the radius; that the length of the radius, or, in other words, the distance of the face-plate from the center, may

be determined by the screw *d*, working through the yoke P; that the angle which said radius has with the bed A may be varied by the tangent screw *f*; that the drill-arbor bearings D D' may be set at different distances from each other by the screws J J'; that the parallel bars G G', moved by the racks H H' and pinions, enable all the drills at once to enter or leave the work.

I claim as my invention—

1. The face-plate W, adjustable on the center *s*, in combination with the drill-arbors D D', as and for the purpose described.

2. The face-plate W, in combination with the drill-arbors D D' and the graduated arm Q, as and for the purpose described.

3. The face-plate W, in combination with the drill-arbors D D', the screw X, and ratchet Y, as and for the purpose described.

4. The face-plate W, in combination with the drill-arbors D D', the screw X, ratchet Y, and stops *b b'*, as and for the purpose described.

5. The radius Q, provided with vertically-adjustable centers N N', in combination with the face-plate W, as and for the purpose described.

6. The radius Q, provided with the screw *d*, in combination with the swinging yoke P, as and for the purpose described.

7. The radius Q, in combination with the carrier *h*, swiveled beam *i*, and tangent screw *f*, as and for the purpose described.

8. The parallel bars G G', in combination with the rack-bars H H', pinions K K', and drill-arbors D D' D'', having the annular grooves F F' F'', all constructed and arranged as herein described, as and for the purpose described.

ARCHIBALD MOORE.

Witnesses:

ALBERT M. MOORE,  
SAMUEL B. WYMAN.