

E. O. RICHARD.

CAR-BRAKE.

No. 182,477.

Patented Sept. 19, 1876.

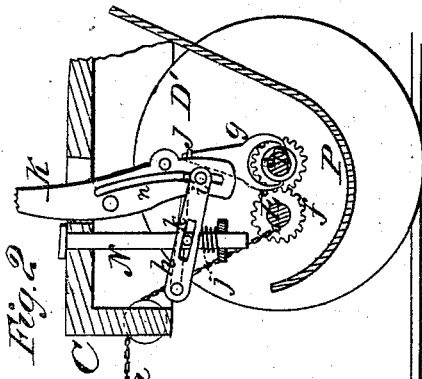

Fig. 2

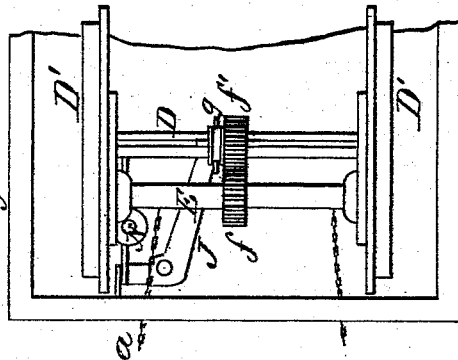

Fig. 4

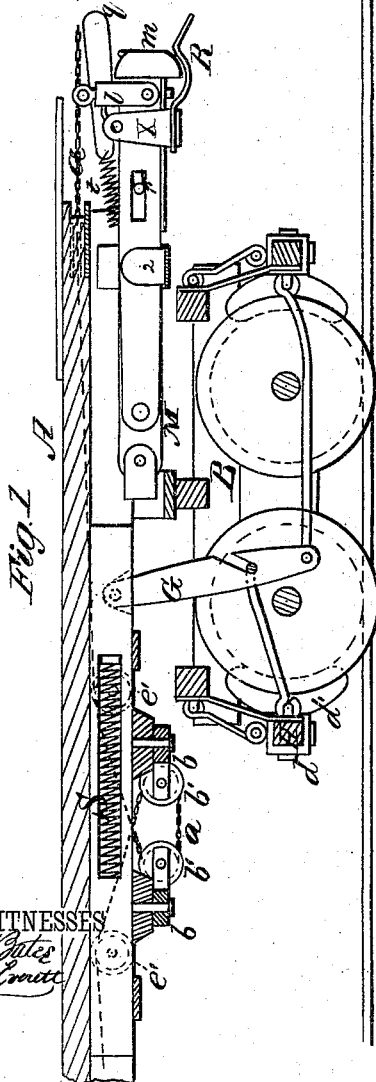

Fig. 1

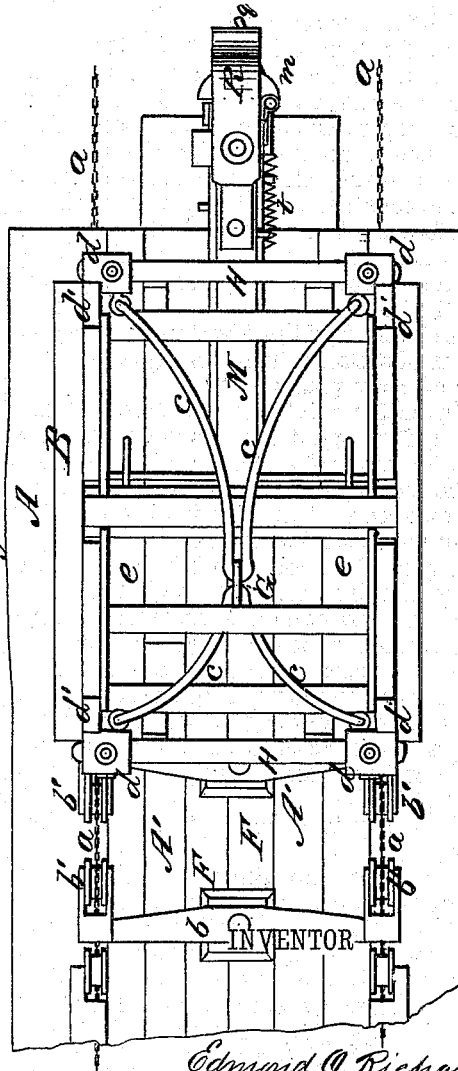

Fig. 3

WITNESSES
E. H. Bates
Robt. Conitt

INVENTOR
Edmond O. Richard
Chipman and Fisher & Co
Attorneys

UNITED STATES PATENT OFFICE.

EDMOND O. RICHARD, OF QUEBEC, QUEBEC, CANADA, ASSIGNOR OF PART INTEREST TO JEAN E. RICHARD, OF COLUMBIA, SOUTH CAROLINA, AND JOSEPH C. RICHARD, OF QUEBEC, CANADA.

IMPROVEMENT IN CAR-BRAKES.

Specification forming part of Letters Patent No. 182,477, dated September 19, 1876; application filed August 8, 1874.

To all whom it may concern:

Be it known that I, EDMOND O. RICHARD, of Quebec, in the Province of Quebec and Dominion of Canada, have invented a new and valuable Improvement in Automatic Car-Brakes; and I do hereby declare that the following is a full, clear, and exact description of the construction and operation of the same, reference being had to the annexed drawings making a part of this specification, and to the letters and figures of reference marked thereon.

Figures 1 and 2 of the drawings are representations of sectional views of my car-brake. Figs. 3 and 4 are plan views.

This invention relates to car-brakes of the automatic kind; and it consists in a novel way of arranging the brake-chains and pulleys between the trucks, and also in an arrangement of draw-rods, so that these rods draw directly on the brake-shoes, instead of on the brake-bars between the shoes. It also consists in certain mechanism, combined with the drum on which the brake-chains are wound, and with the hand-lever used to cut off steam in stopping the engine, whereby the engineer can give motion to the winding-drum simultaneously with the shutting off of steam or reversing, or he can actuate the said lever independently of the winding-drum, as will be hereinafter explained.

The following is a description of my improvements:

In the annexed drawings, A designates a portion of the bed of a passenger-coach, and B a truck applied underneath the bed in the usual manner. C designates part of the locomotive-frame; D, the axle of the drivers D', and E a windlass, on which brake-chains *a a* are wound in applying the brakes. Between the two longitudinal beams A' A' of the car-bed are two longitudinally-movable bars, F F, to each one of which a single-tree, *b*, is pivoted, so as to vibrate freely, which tree has two pulleys, *b' b'*, attached to its extremities, as shown in Fig. 3. Each bar F has a brake-lever, G, pivoted to one end of it, which lever extends down between the axles of the truck-

wheels, and is connected by bail-rods *cc* to the tubular shanks *d d* of brake-shoes *d' d'*. The rods *cc* are connected as near the brake-shoes as possible, so that, in applying the brakes, the brake-rods H H are not subjected to strain. The brake-rods are hung by straps from the truck-frames, and acted on by springs in the usual well-known manner.

The brake-chains, which are attached to the windlass E, extend back beneath the different cars of the train, and for each car these chains pass through tubes *e e*, over pulleys *e' e'*, and over and under pulleys *b' b'*. At the rear end of the rearmost car the chains *a a* are suitably secured.

When the chains are wound on the windlass E the bars F F of each car in the train will be moved in opposite directions, and the brake-shoes will be forcibly pressed against the peripheries of the wheels; and when the brake-chains are slackened, springs S, acting on the bars F, will move these bars back and take up the slack.

The windlass E has a spur-wheel, *f*, keyed fast on it, which wheel engages, at times, with a wheel, *f'*, on the axle of the drivers D'. Wheel *f'* is allowed endwise play on the axle D, and is engaged with this axle by means of a feather and groove. Wheel *f'* has an annularly-grooved collar on one end of it, the groove of which is embraced by a forked pendant, *g*, which is secured to the longest arm of a laterally-vibrating lever, J. The short arm of this lever J is pivoted to a vertically-vibrating connecting-rod, *h*, which extends forward and is connected to the lower arm of the reversing-lever K by means of a stud, *i'*, and a long curved slot, *n*, shown in Fig. 2. N designates a treadle, which extends up vertically through the floor of the locomotive, in rear of the reversing-lever K, and is held up by means of a spring, *j*. This treadle is connected to the rod *h* by means of a pin and slot, *k*, which allows free play.

When the treadle is up the stud *i'* is in such a position relatively to the fulcrum of the lever K, that this lever can be operated freely and independently of the wheel *f'*. When the

treadle is depressed, as shown in Fig. 2, the stud *v* will be carried below the fulcrum of lever K, so that when this lever is drawn back it will cause wheel *f'* to engage with the wheel on the windlass and rotate this windlass, thus winding up chains *a a* and applying the brakes. When treadle N is released, spring *j* will throw it up, and at the same time disengage the wheel *f'* from wheel *f*. P designates a guard beneath the windlass E, for receiving the slack of the chains *a a* and protecting the gearing.

What I claim as new, and desire to secure by Letters Patent, is—

1. Brake-chains *a a*, applied around pulleys *e' e'* and *b' b'*, in combination with single-trees

b b, longitudinally-movable bars F F, brake-levers G, and rods *c c*, connecting with the brakes, substantially as described.

2. In combination with the winding-drum E, fast spur-wheel *f*, and shifting spur-wheel *f'*, the yoke *g*, arm J, connecting-rod *h*, treadle N, and reversing-lever K, substantially as described.

In testimony that I claim the above I have hereunto subscribed my name in the presence of two witnesses.

EDMOND O. RICHARD.

Witnesses:

GEORGE E. UPHAM,
H. C. HOLLINGSHEAD.