

E. ROGERS.

MACHINE FOR MOLDING AND PRESSING BRICK BY HYDRAULIC PRESSURE.

No. 182,481.

Patented Sept. 19, 1876.

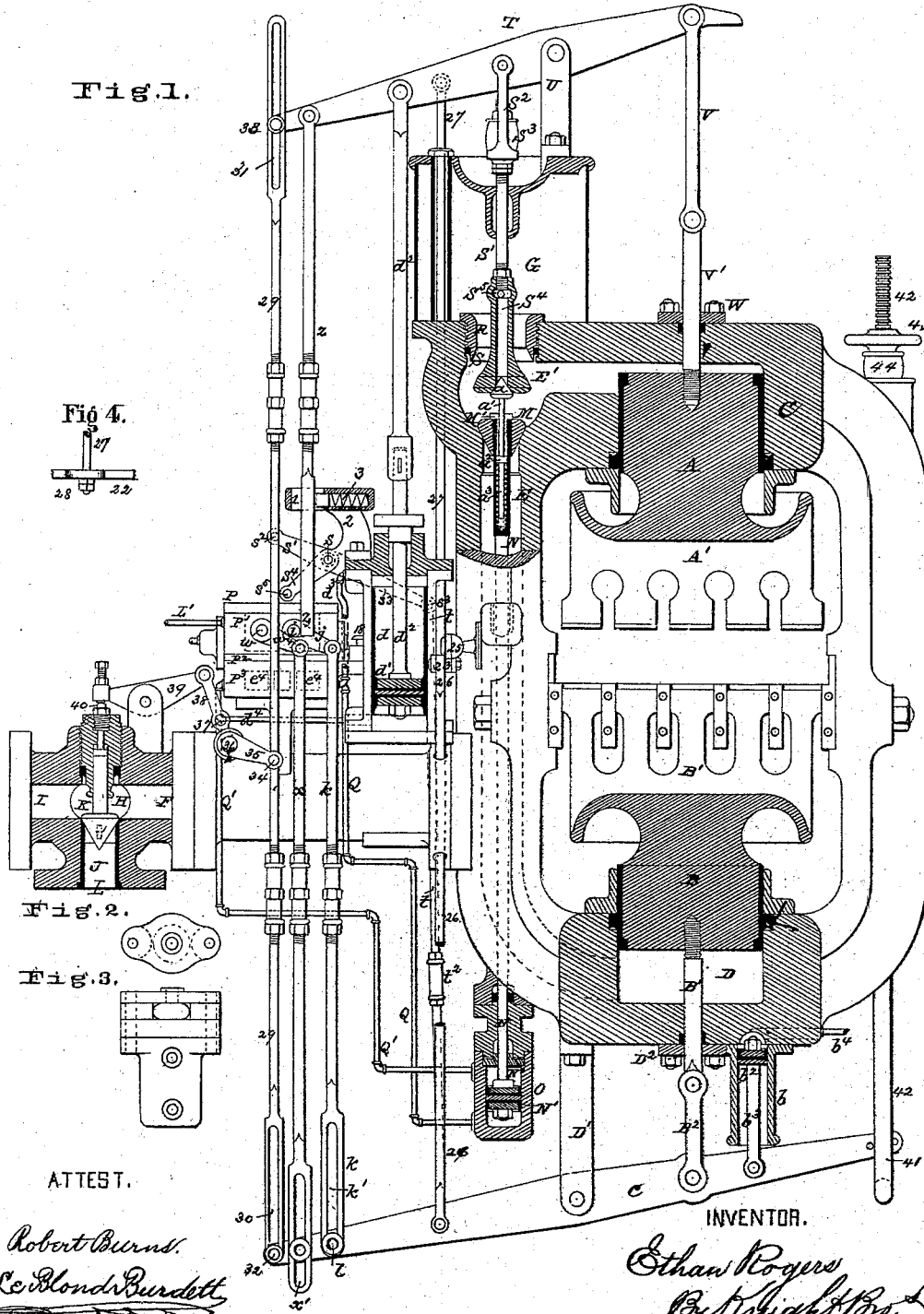

Fig. 1.

Fig. 4.
2.8 2.2

Fig. 2.

Fig. 3.

ATTEST.

Robert Burns.
Le Blond Burdett

INVENTOR.

Ethan Rogers
By Knight Bros.
Atty.

E. ROGERS.
MACHINE FOR MOLDING AND PRESSING BRICK BY HYDRAULIC
PRESSURE.

No. 182,481.

Patented Sept. 19, 1876.

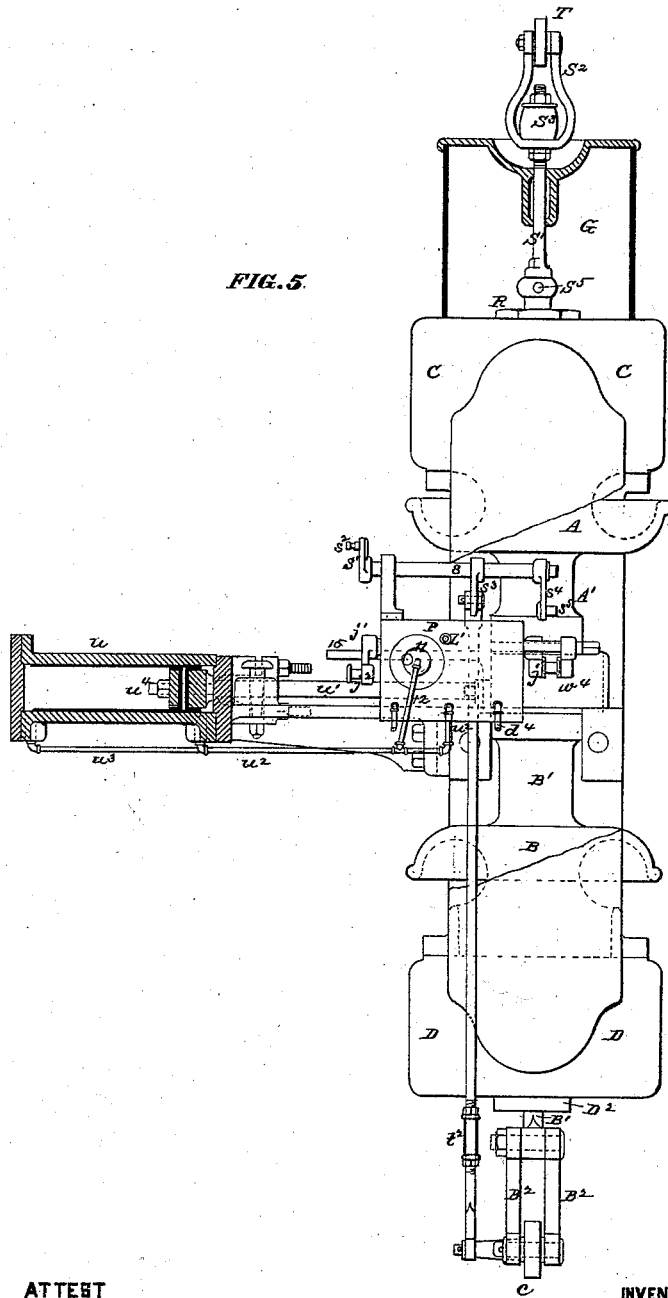

FIG. 5.

ATTEST

Robert Burns
Le Blond Burdett

INVENTOR.

Ethan Rogers
By Knight Bros.
Atty.

E. ROGERS.
MACHINE FOR MOLDING AND PRESSING BRICK BY HYDRAULIC
PRESSURE.

No. 182,481.

Patented Sept. 19, 1876.

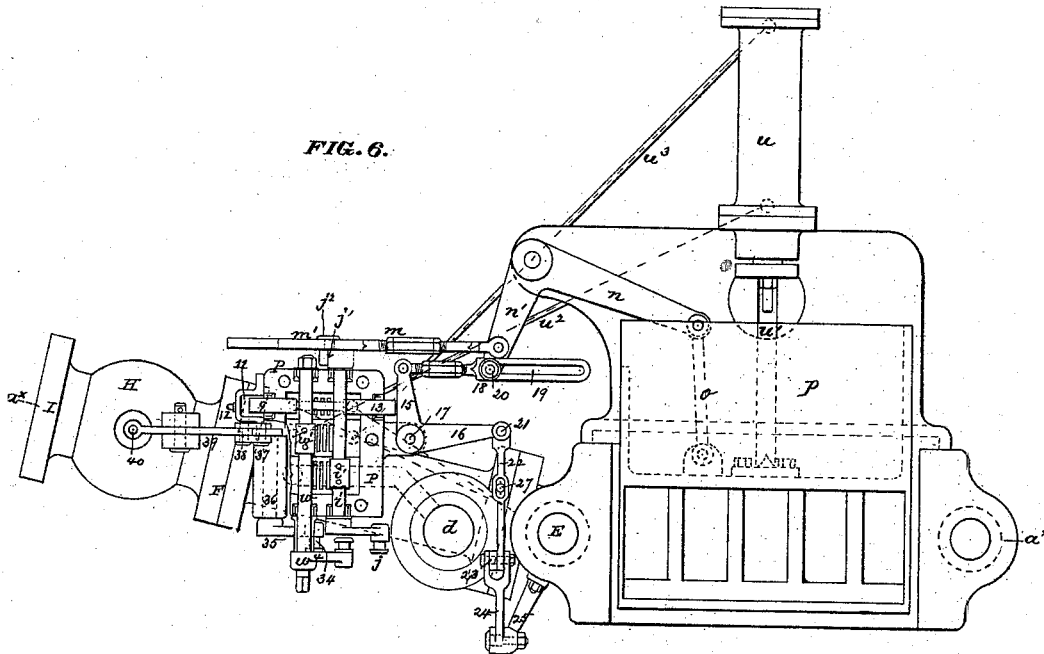

FIG. 6.

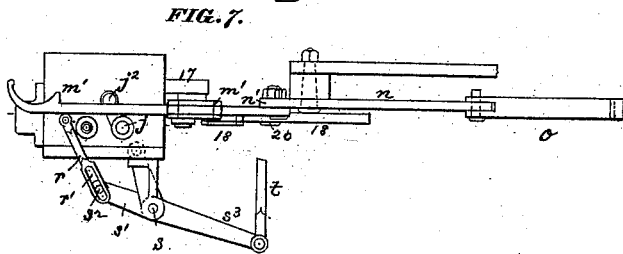
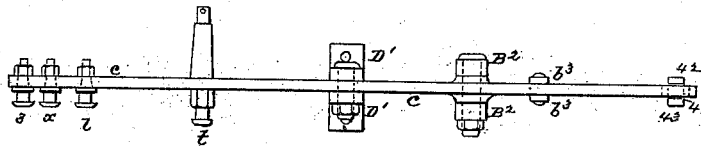

FIG. 7.

FIG. 8.



ATTEST.

Robert Burns.

Le Blond Burdett

INVENTOR.

Ethan Rogers
By Knight Bro.
Atty

E. ROGERS.

MACHINE FOR MOLDING AND PRESSING BRICK BY HYDRAULIC PRESSURE.

No. 182,481.

Patented Sept. 19, 1876.

FIG. 9. g^x

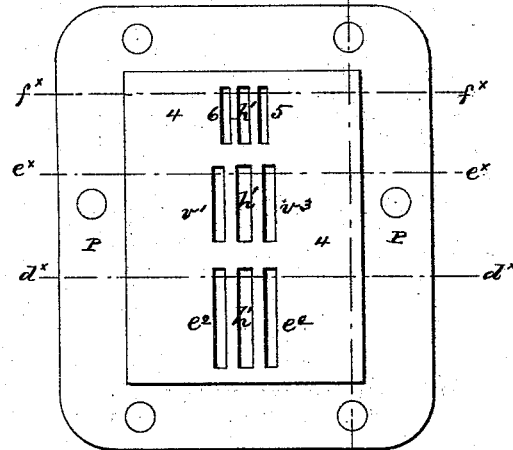

FIG. 10. g^x

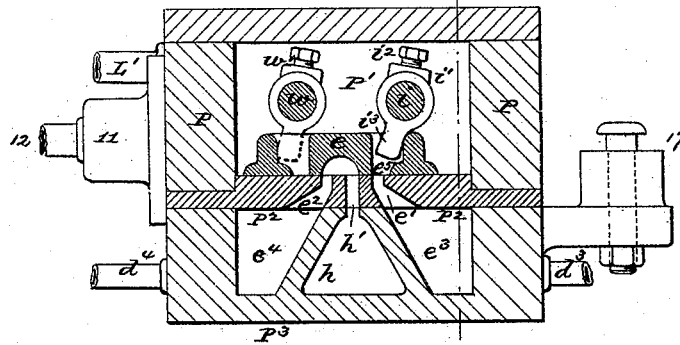
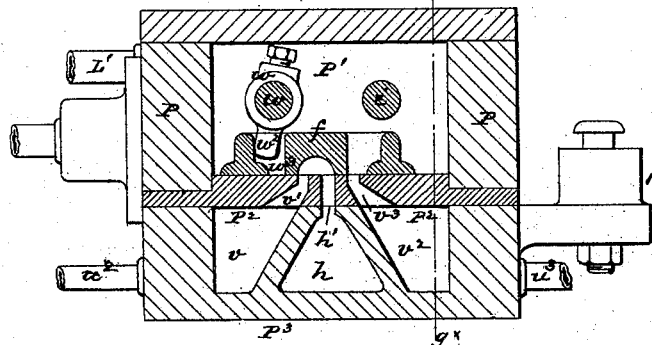

FIG. 11. g^x



ATTEST:

Robert Burns.
Lc Blondi Burdett

INVENTOR:

Ethan Rogers
By Knight Bros.
Atty

UNITED STATES PATENT OFFICE.

ETHAN ROGERS, OF CLEVELAND, OHIO.

IMPROVEMENT IN MACHINES FOR MOLDING AND PRESSING BRICK BY HYDRAULIC PRESSURE.

Specification forming part of Letters Patent No. 152,451, dated September 19, 1876; application filed June 20, 1876.

To all whom it may concern:

Be it known that I, ETHAN ROGERS, of Cleveland, in the county of Cuyahoga and State of Ohio, have invented a new and useful Improvement in Machines for Molding and Pressing Bricks by Hydraulic Pressure, which improvement is fully set forth in the following specification, reference being had to the accompanying drawings.

The first part of my improvement consists in the construction of the valve-box, which has a central seat-plate common to the three valves, and water-supply and exhaust chambers also common to all the valves.

The second part of my improvement consists in the combination of the appropriate valve and connections with the feeder, as hereafter described.

The third part of my improvement consists in the combination of the appropriate valve-connections with the water-engine, by which is operated the valve by which communication between the upper follower-cylinder and the water-supply is opened and closed.

The fourth part of my improvement consists in the combination of the appropriate slide-valve and connections with the reversing-engine of the upper follower-piston.

The fifth part of my improvement consists in the combination device by which is held shut the valve closing communication between the low-pressure pump and the mold follower-cylinder.

The sixth part of my improvement consists in the combination of parts forming the adjustable stop device for the lower follower-piston in its descent.

This invention is mainly an improvement on my brick-machine patented September 23, 1873, No. 143,188.

Figure 1 is a vertical section at $a^x a^x$, Fig. 6. Figs. 2 and 3 are, respectively, top and side views of the reversing-engines of the valve by which communication is closed between the water-supply, and the cylinder of the upper follower-piston. Fig. 4 is a diagram illustrating the tripping device of the pawl which prevents the reversal of the slide-valve of the aforesaid engine. Fig. 5 is an elevation, showing the feeder-engine and discharge-water chamber in section at $b^x b^x$, Fig. 6. Fig. 6 is

a horizontal section at $c^x c^x$, Fig. 1. Fig. 7 is an inverted side view of part of the valve-gear of one of the slide-valves. Fig. 8 is a top view of the walking-beam to which the lower follower-piston is connected. Fig. 9 is a plan of the seats of the slide-valves. Fig. 10 is a vertical section through the valve-box at $d^x d^x$, Fig. 9. Fig. 11 is a vertical section through the valve-box at $e^x e^x$, Fig. 9. Fig. 12 is a vertical section through the valve-box at $f^x f^x$, Fig. 9. Fig. 13 is a vertical section at $g^x g^x$, Fig. 9.

The hydrostatic pistons A and B, with the mold-followers or platens A' and B', are similar to those described in my before-mentioned invention, except that the followers are fewer in number, and the pistons proportionally reduced in diameter. The cylinders C and D are also similar to those described in aforesaid patent, also the general principle of operation, the bricks being compressed to a certain degree by water under a certain pressure, and the pressure upon the bricks being completed by water under a higher pressure.

My present improvement relates to the mechanical devices by which the motions of the press are controlled.

The cylinders C and D are both in communication with a vertical water-pipe, E, receiving water through a supply-pipe, F. The upper end of the pipe E is in communication, through a valve-chamber, E', with an outflow-water chamber, G, from which the water escapes into the supply-tank of the pressure-pumps.

The water enters the pipe F through a valve-chamber, H, in constant communication, through a pipe, I, with the high-pressure pump. The valve-chamber H is in communication, through the port J of the valve K, with the low-pressure pump by means of the pipe L. The valve K is free to drop at all times, except when forced up by the entrance of water into the valve-chamber from the low-pressure pump. The valve is held down at intervals against the pressure of the water from the low-pressure pump, as and for a purpose hereafter described.

The valve-chamber E' contains three valves. The lower valve, M, is seated in the bottom of the chamber, and has a stem, N, passing down

axially through the pipe E, and ending in a piston, N', which works in a cylinder, O, receiving water from the valve-box P through pipes Q Q', to raise or lower the piston N', and with it the valve M. The valve M acts to shut off the communication between the pipe E and cylinder C. R is a valve-seat at the top of the chamber E', and S is a valve working against said seat, and acting to close communication between the chamber E' and the outflow-chamber G. The stem S¹ of the valve S passes upward through the top of chamber G, and is attached to the lever T, fulcrumed upon a standard, U, and having one end secured by means of rods V and V' to the piston A. The rod V' is firmly attached to the piston A, and extends vertically upward through a stuffing-box, W, in the top of the cylinder C. The rod V is jointed to the rod V' and lever T. The connection between the valve-stem S¹ and lever T is not rigid, but is made by means of a stirrup-link, S², hanging from the lever, through whose lower part the stem passes; and the stem also passes through a rubber-block spring, S³, and has nuts screwed upon its end, resting upon the top of the spring. The arrangement is such that when the valve is raised firmly against its seat that end of the lever T may continue to rise, and the spring is compressed, thus causing no breakage of parts, such as would result if the connection between the valve and lever were rigid.

The valve S is tubular at S⁴, forming the port of the valve a, of which the bottom of valves S forms the seat. S⁵ are radial orifices leading from port S⁴ into the water-chamber G. The stem a¹ of valve a works axially in the valve M. Said stem has a collar, a², which prevents its being drawn out of its bearing in the valve, the collar engaging the inner side of a bushing, M', which is screwed into the valve, and which forms the bearing of the stem a¹. Beneath the collar a², forming the lower end of the stem a¹, is a spiral spring, a³, tending to keep the collar in contact with the bushing M'. b is the reversing-cylinder of the lower mold-piston B. The lower end of this cylinder is open, and its upper end above the piston b² is constantly supplied with water under pressure by a pipe, b⁴, communicating with the low-pressure-pump pipe L. The rod b³ of the piston is connected to the lever c, fulcrumed to a hanger, D¹, and connected to the lower piston B by jointed rod B² and rigid rod B¹, the latter passing through a suitable stuffing-box, D². d is the reversing-cylinder of the upper mold-piston A, and d¹ is the piston therein, whose rod, d², is connected to the lever T. This cylinder receives water from the valve-box P, to operate the piston through water-pipes d³ d⁴.

The upper chamber P¹ of the valve chest or box P is in constant communication, by a pipe, L', with the low-pressure pipe L, so as to contain water under a constant pressure. Extending horizontally across the interior of the

valve-box is the seat-plate P², having suitable seats and ports for the slide-valves e f g. The lower part P³ of the valve-box has a central chamber, h, extending across it transversely to the valves, and in communication with the supply-tank of the pumps. The exhaust-ports h' of all the valves are in communication with chamber h. The end ports e¹ e² of valve e communicate with chambers e³ e⁴, connected, respectively, by the pipes d³ d⁴ with the cylinder d.

The valve e is operated by the following means: i is a rock-shaft extending through the valve-box. Above the valves on this shaft is a collar, i¹, adjustable and held in position by a set-screw, i². i³ is a lug on the under side of the collar, extending downward into the opening e⁵, through which the water descends to the water-port e¹. The ends of the shaft i, outside the valve-box, carry crank-arms j and j¹, the former of which carries a pitman-rod, k, slotted at k', and in which slot plays a pin, l, projecting from the side of lever c. The arrangement is such that, when the outer end of the lever c is depressed, (by the upward movement of the piston B,) the arm j shall be drawn down, and shall slide the valve e, so as to admit the water into the top of cylinder d, to raise the upper piston A, and allow the bricks to be pushed from the top of the molds. The slide-valve e is moved in the opposite direction (so as to allow the water under pressure to enter the bottom of the cylinder d) by a rod, m, having a catch, m', engaging the pin of crank-arm j¹, and whose end is pivoted to the bell-crank lever n n' fulcrumed to the frame, and having its arm n connected, by a link, o, to the feeder p. This feeder is similar in construction and action to that described in my former patent, No. 143,188. The arrangement of the catch-rod m is such that, when the feeder moves back from beneath the mold-piston A, the valve e is reversed, as stated, so as to allow the piston A to descend upon the clay in the molds. At the proper time, during the descent of the lower mold-piston B, the catch m' is raised from its engagement with pin j² of cam j¹, so as to allow the valve e to be reversed by the rod k, as before described.

The mechanism for raising the catch-rod m is as follows: Connected to said rod is a link, r, slotted at r' to receive a pin, s², on an arm, s¹, of a rock-shaft, s. This shaft has another arm, s³, connected by a rod, t, to the lever or beam c; and as the outer end of beam c descends the arm s³ is depressed, and that s¹ raised, which brings the pin s² against the upper end of the slot r', and the catch m' is disengaged from pin j². u is the cylinder of the water-engine, by which the feeder p is reciprocated, the piston-rod u¹ of said engine carrying a piston, u², and being attached directly to the feeder. u² and u³ are pipes leading to the slide-valve f of said engine. The pipe u² leads from the inner end of said cylinder to the water-space v, in connection with the

valve-port v^1 , and the pipe w^3 communicates between the outer end of cylinder u and the space v^2 , in communication with port v^3 . The valve f exhausts through water-way or chamber h .

The valve f is actuated by the following means: w is a rock-shaft passing through the valve-box above the valve. Upon this shaft is an adjustable collar, w^1 , having a lug, w^2 , extending down into the water-passage w^3 in the slide-valve, so that as the shaft is oscillated the valve is reciprocated upon its seat. w^4 is a crank-arm on the rock-shaft, connected by its pin to a pitman-rod, x , which has a vertical slot at x' receiving a pin projecting from the side of the lever or beam c . By the upward movement of that end of the beam c (as the piston B descends) the arm is raised and the slide-valve f is moved outwardly, so as to allow the water to pass through the port v^1 and pipe w^2 to the inner end of the feeder-cylinder, to carry the feeder with its surplus clay back from beneath the followers A' of piston A, as described in my former patent, No. 143,188. As the feeder moves backward it moves back the bell-crank arm n , and draws inward the arm n' and the rod m , which reverses the valve e , as before described.

The upward movement of the mold-piston A reverses the valve f by the following means: Hanging from the long end of the beam-lever T is a pitman, z , rectangular at the lower end, and passing through a guide-slot, 1, in bracket 2. The lower end of the pitman is forced outward by a spring-pin, 3, sliding in a bearing in the bracket. The purpose of this is to hold the lower end of the pitman in line with the upper (rectangular) end of the pitman z , so that as the pitman z descends it carries down with it the pitman x , and reverses the valve f , so as to cause the feeder to move forward by the water passing through the valve-port v^3 and pipe w^3 to the outer end of the cylinder w , so that the feeder is made to move forward and charge the molds each time the follower-piston A attains its upper position.

As the lower follower-piston B is about to reach its lower position, the pin l on the beam c reaches the top end of the slot x' , and, by lifting up the pitman z , reverses the valve f , and the feeder is drawn back from the molds. Just prior to this upward movement of the pitman z , the lower end of the pitman z is drawn off the upper end of x by the following means. Upon the rock-shaft s is an arm, s^4 , whose pin s^5 is brought against the side of the pitman z , as the arm s^3 is raised by its connection (by pitman-rod t) with the beam c . By the adjustment of the length of this rod, which may be done by a right and left hand screw coupling, t^2 , the time of the movement of the arm s^4 , relatively to the piston B, is regulated.

The movement of the valve-engine N' O is governed by the movement of the slide-valve g . This valve works on the seat 4, on the plate P², which has a central exhaust-port,

h' , and end ports 5 and 6, the exhaust-port opening into the exhaust-chamber or passage h , like the exhaust-ports of the other valves, and the water passing down from the upper part or chamber P¹, through openings 7 and 8, to the ports 5 and 6, respectively, according to the position of the valve, the water under pressure, when the valve g is in its outer position, passing through ports 7 and 5 and the pipe Q to the lower end of the cylinder O, and the port 6 being then an exhaust-port, and in connection with port h' and water-passage h .

When the valve g is in its inner position the water under pressure passes through the ports 8 and 6, and through the pipe Q', to the upper end of the cylinder O, and draws down the piston to close the valve M, the water exhausting from the lower part of the cylinder through the pipes and ports Q, 5, 7, h' , and h , and so to the pump supply, tank, or reservoir.

When there is a pressure of water on the inner side of the feeder-piston w^4 , and in the pipe w^2 in connection therewith, there is always a tendency of the valve g to move inward, owing to the pressure of water upon the outer end of its plunger-piston 9, which extends through a stuffing-box, 10, into a chamber, 11, in communication with the pipe w^2 through a pipe, 12, and, by the above means, this valve is moved inward whenever freed from other influences.

The valve g has at the inner end a rod, 13, passing through a stuffing-box, 14, and extending outside the valve-box P. 15 16 is a bell-crank fulcrumed at 17. The arm 15 of this bell-crank comes in contact with the end of the rod 13 each time the feeder moves forward, the arm 15 having jointed to its end a rod, 18, whose other end is slotted at 19 to receive a pin, 20, on the upper side of bell-crank arm n' ; and as the arm n' is moved toward the valve-box the pin 20 impinges against the rod 18 at the end of slot 19, and the arm 15 is forced outward against the rod 13 and reverses the valve, so as to admit the water under pressure to the lower end of the cylinder O, and the valve M is raised from its seat.

When the bell-crank 15 16 is carried around into the position last described it is held in this position until the process of pressing the bricks is concluded by the following means: Upon the top of the arm 16 is a pin, 21, which is engaged by a toggle-pawl to hold it in said position. The toggle-pawl has a bar or pawl proper, 22, notched at one end to engage the pin 21, and hinged at the other end 23 to the bar 24. The other end of the bar 24 is hinged to a bracket, 25. 26 is a vertical rod connecting the hinge 23 and the beam-lever c . 27 is a rod depending from the lever-beam T and passing through the bar 22, and having at the lower end an adjustable head or jam-nut, 28. As the piston descends and the outer end of the lever-beam T rises the head 28 is brought in contact with the bottom of bar 22, and the

notched end of the pawl-bar is drawn off the pin 21 to allow the bell-crank 15 16 to move backward under the influence of the valve-rod 13.

The time of release of the pawl 22 is modified by the movement of the lower follower-piston B, owing to its action through the rod 26 upon the hinge 23.

It will be seen that the pawl 22 is released when the two pistons A and B have approached within a certain distance of each other, so that the bricks will be of a uniform thickness, and this thickness may be regulated to adjustment of the head 28 upon the rod.

29 is a rod, with lower slot 30 and upper slot 31. In the slot 30 plays a pin, 32, projecting from the side of the beam-lever *c*, and a pin, 33, on the side of lever T, plays in the slot 31. In this rod turns the wrist-pin 34 of an arm, 35, upon a rock-shaft, 36.

The shaft 36 carries an arm, 37, connected by a toggle-link, 38, with one end of a lever, 39, whose other end rests on a pin, 40, whose lower end rests upon the valve K. The arrangement is such that the toggle 37 38 is carried up just past its center by the lever, *c*, acting through the pin 32 and rod 29, the pin drawing down the rod by pressure against the lower end of the slot 30. When the toggle is in this position the valve K is held tightly down on its seat to keep the port closed against the entrance of water from the low-pressure pump into the valve chamber H. As the piston A descends the pin 33 reaches the upper end of the slot 31, and the arm being drawn up the pin 40 is relieved from the pressure of the lever 39, and the valve K is allowed to rise.

The downward movement of the piston B is limited by the lever *c*, the end of the lever, to which the piston B is connected, sliding in a slot, 41, at the lower end of a vertical rod, 42, which passes through the frames of the machine, and whose upper end is screw-threaded, and carries an adjusting-nut, 43, which rests upon a rubber spring, 44. By adjusting the nut upon the rod the position of the rod is regulated, and consequently the lower position of the cylinder, in which position the lever rests against the lower end of slot 41.

The operation of the press, as far as relates to the movements of the pistons A B, (with their followers;) the valves M, S, *a*, and K, and the movements of the feeder, are precisely like those of my patent aforesaid, upon which this is an improvement; and the pipes leading to the valve-chamber H, from the high and low pressure pumps, are supplied with weighted valves, as in my former patent, allowing the escape of water from said pipes into the supply-tank when the water has attained a certain pressure. The movements of the various parts have been minutely described; and I will now give a short explanation of the movement of the parts in the production of one pressing of bricks. Suppose both of the follower-pistons to be in their up-

per position, as shown in the drawings. The feeder *p*, moves forward and pushes the last pressing of bricks from the top of the molds, and carries a fresh supply of clay over the molds.

The feeder *p*, by moving forward, reverses the valve *g* and opens the valve M, so that the waters can escape from the lower cylinder through the valve-chamber E' into the out-flow-chamber. This allows the lower follower to drop to open the molds, the downward movement of the followers being limited by the beam-lever *c* and rod 42. As the follower-piston B descends the valve *f* is reversed to draw back the feeder. As the feeder reaches its backward position it acts through bell-crank *n n'* and rod *m* to reverse the valve *e*, which forces up the piston *d*, and the follower-piston A descends. The descent of this piston closes the valve S, and the valve *a* ascending with valve S, owing to the pressure of the spring *a*³, and allows the valve K to open by relieving the pin 40 from the pressure of the lever 39 through connections 29, 31, 33, 34, 35, 36, 37, and 38. There is no way of escape of water from the pipe or trunk E, and consequently the pressure of the water is brought upon both pistons A and B, and the bricks are compressed to as great a density as the low-pressure pump is capable of imparting. At this time the valve K drops upon its seat and prevents the escape of water from the valve-chamber H into the low-pressure-pump pipe L, and the pressure of the high-pressure pump is brought upon both pistons A and B.

On the lower piston B reaching a certain elevation, and the upper piston A descending to a certain point, the pawl 22 is drawn from the pin 21, and the pressure of water at the end of the plunger-piston 9 13 of valve *g* reverses the said valve, and the valve M is drawn down to its seat, closing the communication between water-trunk E and cylinder C. As the valve M is drawn down, it draws the valve *a* from its seat, and the water escapes from the chamber E' through the central opening S⁴ of valve S. The piston B then carries up the bricks, and the piston B holds the valve K shut, by means of lever *c*, rod 29, rock-shaft 36, toggle 37, 38, lever 39, and pin 40. As the piston B attains its highest elevation with the tops of the followers B' flush with the tops of the molds, the valve *e* is reversed by lever *c* and rod *t*, which causes the descent of the piston *d*¹, and the followers A' are raised from the bricks, (the piston *d*¹ acting on that A through the medium of lever T.) As the piston A reaches its highest position, the lower end of the pendent rod *z* descends upon the head of the rod *x*, and reverses the valve *f*, to move forward the feeder. As the lower cylinder B descends, it acts through lever *c*, rod *t*, arm *s*³, rock-shaft *s*, arm *s*⁴, and pin *s*⁵ to push the lower end of rod *z* from the head of rod *x*, so that the valve *f* may be reversed by the continued descent of piston B. As the

feeder attains its forward position, it reverses the valve *g*.

I claim as my invention—

1. The valve *e f g*, in combination with the valve-box P and plate P², forming the seat for all the valves, substantially as set forth.

2. The combination of feeder *p*, link *o*, bell-crank lever *n n'*, rod 19, bell-crank lever 16 17, and valve *g*, substantially as set forth.

3. The combination of valve *g*, bell-crank lever 15 16, with pin 21, toggle-pawl 22 24, pitman-rod 26, beam *c*, rod 27, and beam T, substantially as set forth.

4. The combination of valve-box P, valve *g*, pressure and exhaust ports 5, 6, and *h'*, respectively, water-pipes Q and Q', engine O N N', and valve M, substantially as set forth.

5. The combination of feeder *p*, engine *u w u'*, pipes *w² w³*, valve *f*, ports *v v¹ v² v³ h'*, shaft *w*, with arms *w² w⁴*, rod *x*, and beam *c*, with pin working in slot *x'* of said rod, substantially as set forth.

6. The combination of the valve *f*, having shaft *w*, and arm *w⁴*, with pitman *z*, beam T, spring-pin 3, shaft *s*, arms *s³ s⁴*, pitman *t*, and beam *c*, substantially as and for the purpose set forth.

7. The combination of upper mold-piston A, beam T, reversing-engine *d d¹ d²*, water-pipes *d³ d⁴*, and valve *e*, its water ports and passages *e¹ e² e³ e⁴ h'*, substantially as set forth.

8. In combination of the valve *e*, rock-shaft *i*, lug or arm *i²*, arm *j*, pitman *k*, and beam *c*, arm *j¹*, rod *m*, bell-crank lever *n n'*, rod *o*, and feeder *p*, substantially as set forth.

9. The combination of the valve *e*, shaft *i¹*, arm *j¹*, rod *m*, bell-crank *n n'*, feeder and rod *p, o*, link *r*, rock-shaft *s*, with arms *s¹ s³*, pitman-rod *t*, and beam *c*, substantially as set forth.

10. The combination of valve K, pin 42, lever 41, toggle 38 37, rock-shaft 36, arm 35, slotted rod 29, and beams T and *c*, substantially as and for the purpose set forth.

11. The combination of piston B, rod B¹, link B², beam *c*, vertical stop-rod 42, with slot 41, adjusting-nut 43, and spring 44, substantially as set forth.

ETHAN ROGERS.

Witnesses:

J. BARBER,
THOMAS DIXON.