

H. C. STOFFER.

PIPE-WRENCH.

No. 182,492.

Patented Sept. 19, 1876.

fig. 1.

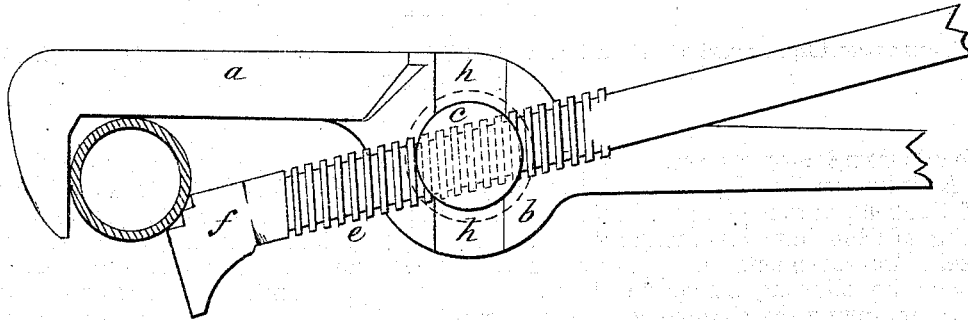

fig. 2.

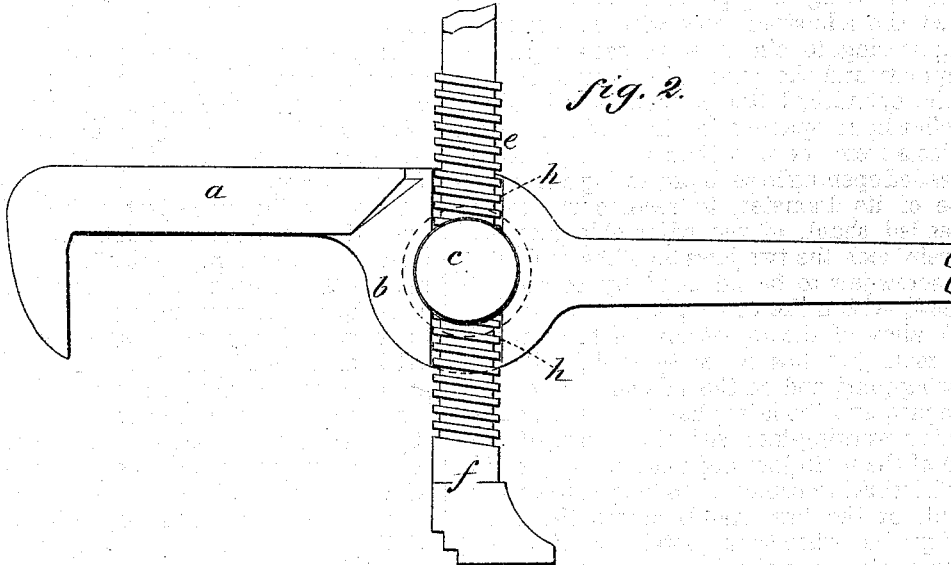

fig. 3.

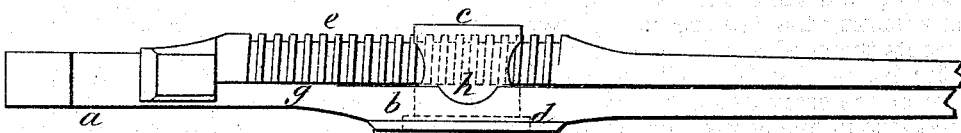
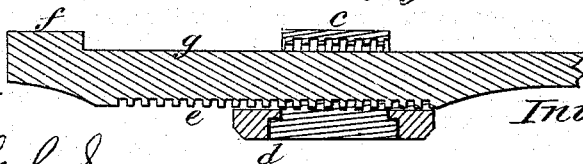

fig. 4.



Witnesses:

J. Rutherford  
Floyd Norris

Inventor:

Hiram C. Stouffer,  
by Johnson & Johnson  
Attorneys.

# UNITED STATES PATENT OFFICE.

HIRAM C. STOFFER, OF CANFIELD, OHIO, ASSIGNOR OF ONE-HALF HIS RIGHT TO JOHN CHILDS, OF SMITH'S FERRY, PENNSYLVANIA.

## IMPROVEMENT IN PIPE-WRENCHES.

Specification forming part of Letters Patent No. 182,492, dated September 19, 1876; application filed April 24, 1876.

*To all whom it may concern:*

Be it known that I, HIRAM C. STOFFER, of Canfield, in the county of Mahoning and State of Ohio, have invented certain new and useful Improvements in Pipe-Wrenches, of which the following is a specification:

In improving the pipe-wrench, I have combined the adjustable jaw with a cylindrical plug-bearing, in a manner to secure greater simplicity and cheapness of construction.

The cylindrical bearing-plug is seated by a collar in an opening in the main jaw, and projects from one side thereof, with a screw-threaded opening in such projecting end, cross-wise of its diameter, to receive the screw-threaded shank of the adjustable jaw, and thereby lock the two jaws together, and allow the screw-jaw to be adjusted by rotating it directly within the screw-plug.

To allow of the adjustment of the wrench, the main jaw has a cavity radial with the bearing-plug, and on the side next the adjustable jaw, and the latter has a flat side, which forms a working-face with the enlarged portion of the main jaw, and holds the adjustable jaw in working condition so long as the screw-shank of the jaw stands across the radial cavity; but when the adjustable jaw is moved to bring its screw-shank coincident with the radial cavity, the screw-jaw can then be rotated to give it the desired adjustment.

In adjusting the jaw the radial cavity receives its threaded shank, so that it can be quickly rotated by its handle to move it in or out in the screw-bearing plug, and bring its flat side in line or working condition with the main jaw.

In the accompanying drawings, Figure 1 represents a side view of my improved pipe-wrench; Fig. 2, a similar view with the screw-jaw in position for adjustment; Fig. 3, an edge view, and Fig. 4 a section through the cylindrical bearing-plugs and jaws, in the positions shown in Fig. 2.

The main jaw *a* has an enlargement, *b*, through a shouldered opening, in which a cylindrical bearing-plug, *c*, is fitted, and held in place at one side by means of an annular end collar, *d*, leaving the plug free to be in-

serted and turned within the shouldered opening, and projecting beyond the face of the enlargement a sufficient distance to bring a cross-screw-threaded opening, formed therein, to one side of the enlarged portion *b*, to receive the screw-shank *e* of the adjustable jaw *f*, and lock the jaws in working position by the direct action of the screw in the plug.

To prevent the screw-jaw from rotating in being opened and closed, it is made flat on one side, at *g*, to form a close bearing-face with the side of the main jaw, the cylindrical bearing-plug turning with the movement of the screw-jaw.

To allow the screw-jaw to be adjusted to suit different pipes, a radial face-cavity, *h*, is made in the enlargement *b* of the main jaw, to receive the screw-shank *e* when it is turned coincident with such cavity, and leave it free to be rotated within the screw of the cylindrical bearing-plug, and thus adjust the jaw *f* in or out to suit the pipe or nut.

So long as the screw-shank stands across the radial cavity it cannot be rotated in the screw-plug; but when the jaw *f* is opened wide enough to bring the flat side of the screw-shank over and in line with the radial cavity, then it can be easily and quickly screwed in or out, and when so adjusted its angular side is then brought coincident with the side of the main jaw and closed for use, so that the jaw can only be adjusted when opened wide, and then only by rotating the handle to screw it through the bearing-plug.

In putting the pipe-wrench together, the cylindrical plug is inserted into the shouldered opening of the main jaw, and the screw-jaw inserted, handle foremost, and screwed into the screw-threaded opening, made diametrically in the projecting end of the cylindrical bearing-plug. No rivets or bolts are needed, and the wrench is strong and cheaply made, quickly and easily adjusted, by rotating one jaw within a screw-plug, which serves to lock it with the main jaw.

I claim—

1. The combination, with the adjustable screw-jaw, of the cylindrical bearing-plug *c*, provided with an interior diameter screw, to

receive the jaw-screw, and allow the latter to be adjusted by rotating it directly within the screw of the plug.

2. The adjustable screw-jaw, provided with the angular bearing side *g*, in combination with the cylindrical bearing-plug *c*, and the main jaw, as and for the purpose described.

3. The adjustable jaw, provided with the angular bearing side, and working by male and female screw directly through the cylin-

dric bearing, as described, in combination with the main jaw, having a radial face cavity, *h*, into which the screw may be turned, as and for the purpose described.

In testimony whereof I have affixed my signature in the presence of two witnesses.

HIRAM C. STOFFER.

Witnesses:

A. H. CLARK,

A. R. MARKALL.