

G. W. COPELAND.

LASTING MACHINES FOR BOOTS AND SHOES.

No. 182,561.

Patented Sept. 26, 1876.

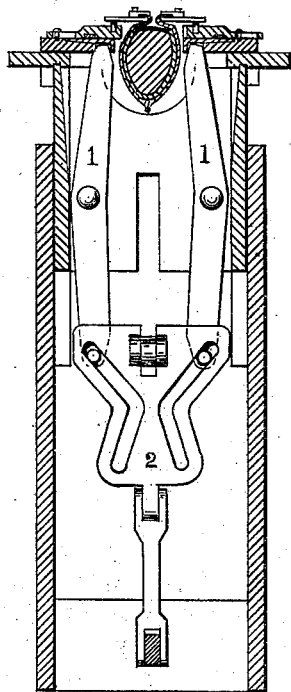

Fig 1

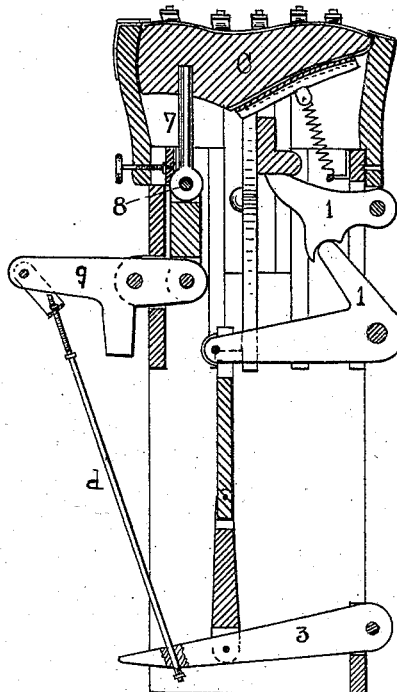

Fig. 2.

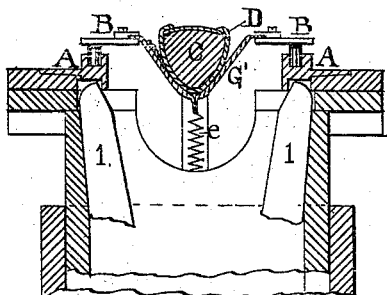

Fig 3

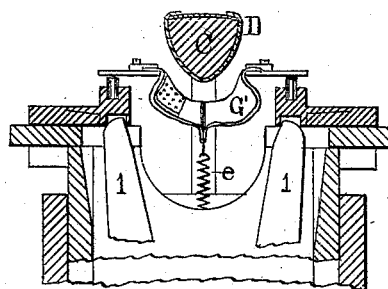

Fig 4.

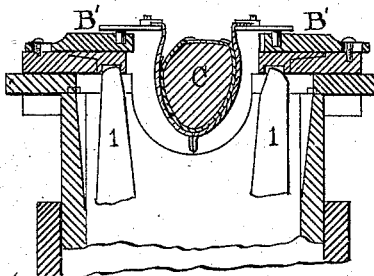

Fig 5.

WITNESSES

Frederic Raymond
Adolph J. Oettinger

INVENTOR

Geo. W. Copeland

G. W. COPELAND.

LASTING MACHINES FOR BOOTS AND SHOES.

No. 182,561.

Patented Sept. 26, 1876.

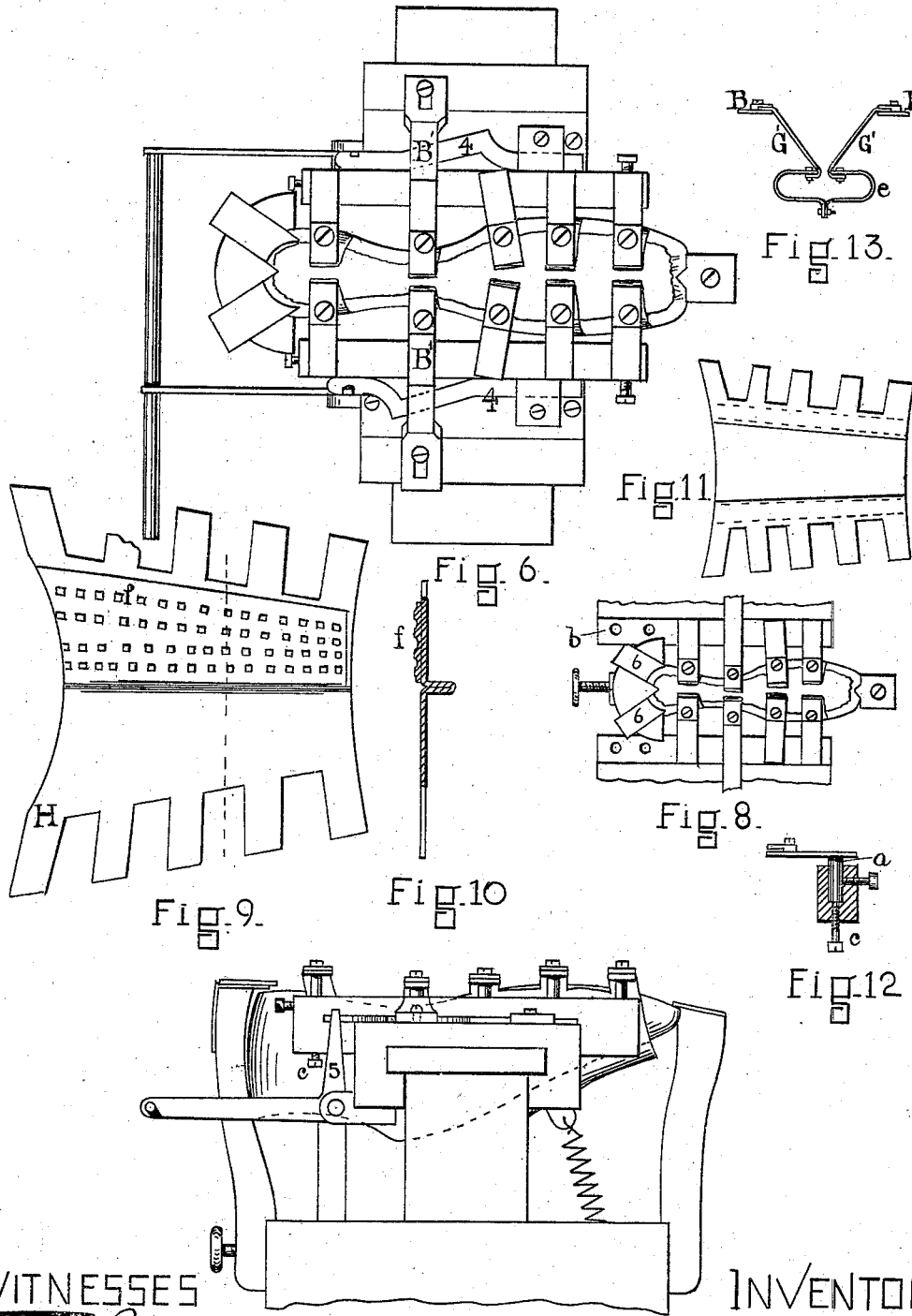

WITNESSES

Frederic F. Raymond.
Adolph J. Cettinger.

INVENTOR

Geo. W. Copeland.

UNITED STATES PATENT OFFICE.

GEORGE W. COPELAND, OF MALDEN, MASSACHUSETTS.

IMPROVEMENT IN LASTING-MACHINES FOR BOOTS AND SHOES.

Specification forming part of Letters Patent No. 182,561, dated September 26, 1876; application filed August 11, 1876.

To all whom it may concern:

Be it known that I, GEORGE W. COPELAND, of Malden, in the county of Middlesex and State of Massachusetts, have invented an Improvement in Lasting-Machines, of which the following is a specification:

This invention relates to that principle of lasting which employs a straining, compressing, and smoothing action upon the upper, begun either on the median line from instep to toe, or from points sufficiently remote from the edge of the last to secure the fitting of the upper to the last by straining the upper upon the same continuously in constantly-succeeding areas to the surface of the insole, and the completion of the lasting by the advance of the lasting-fingers to, or nearly to, the longitudinal center of the insole. It comprises, first, the movement of the jaws carrying the fingers from the line upon which the strain and compression is first exerted to the completion of the lasting; second, the adjustability of the fingers upon the jaws to the varying surfaces and slopes of the bottom and edges of a last; third, the horizontal movement of the fingers and their automatic adjustment, whereby the strain upon the upper is increased or diminished at will. This adjustment is particularly desirable in the shank. Fourth, the automatic adjustment of the height of the last relatively to the fingers and heel-plates; fifth, the combination of lasting-fingers possessing the adjustable features named with an elastic girth, or with a girth inelastic in itself, but combined with springs, as will be hereinafter described; sixth, the combination of lasting-fingers and girth for side lasting with toe and heel plates; seventh, the arrangement of the heel-block relatively to the jaws, whereby an adjustment for varying lengths of last is effected; eighth, in providing the inner surface of the girth with a frictional surface.

These features are represented in the drawing as follows:

Plate 1, Figures 1, 2, 3, 4, and 5 relate principally to movements of the jaws A, fingers B, and girth G relatively to the last C and upper D. In Fig. 2 is also shown the automatic adjustment of the last-spindle 7.

Plate 2, Figs. 6, 7, and 8 show the adjustability of the fingers, and Figs. 9, 10, and 11

refer to the girth. Fig. 12 is a detail view of the means of adjusting the fingers on the jaws, and Fig. 13 shows a girth and spring combined.

The jaws A are operated by the levers 1, cam 2, and lever 3, in the following path: First outward from their lowest point, as represented in Fig. 4, and this movement may be upon the plane of the lowest level; or it may be diagonal to the position shown in Fig. 3; or they may swing out on the arc of a circle, the intention being to develop a strain upon the girth before the same is wrapped upon the upper. The next movement is a vertical one, and the jaws are raised to the level of the insole, or to a point somewhat above the level of the insole, as seen in Fig. 5. This is followed by a closing movement, which may be horizontal or descending.

These jaws are provided with the fingers B, which are arranged upon the jaws at given distances from each other to project to the center of a plane coincident with the surface of the insole when the jaws are closed. Their position is shown in Figs. 6 and 7. These fingers are provided with the pivots *a*, which fit into holes *b* in the jaws, and a vertical adjustment is given them by means of the screws *c*, and they may swivel or not, as desired.

In practice, it is deemed desirable to fasten the end fingers, and even those which shut onto the ball of the last. These fingers are interchangeable, being of the same length; but their height, relative to the jaws, is variable, and is governed by the conformation of the last-bottom, those at the shank being somewhat lower than those at the surface over the ball of the last. This arrangement is distinctly shown in Fig. 7. It is also desirable to give the fingers a horizontal movement, so that their ends may not always project to a given straight line drawn from the center of the toe to the center of the heel, but shall project to a line represented by the mean center line from toe to heel, which necessarily must be somewhat curved. This disposition of the fingers is shown in Fig. 6, and is adapted particularly for use in the shank, inasmuch as, without this adjustment in right-and-left boots and shoes, the girth would not be drawn on the inside of the shank, which is the more

difficult side to last well, so far over as on the outside—that is, the same fingers, if unadjustable horizontally, could not produce with the same girth a strain upon the inside in all cases sufficient to secure a perfectly tight wrapping of the upper over the last at the shank. These horizontally-acting fingers B' are operated by the wedging slides 4 and levers 5.

The adjustment for varying lengths of last is obtained by removing either the toe or heel fingers, or both sets, if necessary, and moving the toe and heel blocks inward. A view of this adjustment is shown in Fig. 8. This enables the same jaws to be used for all lengths of lasts, and it would probably not be necessary to change the girth as often as the number of fingers were increased or diminished, as supplemental girths may be added.

The heel-lasting is obtained by the converging of slides 6, and the block upon which they slide may be adjustable to and from the spindle. This same principle of converging plates may be employed in lasting the toe. The spindle 7, upon which the last is hung, is jointed at 8, as shown, and is raised and stiffened by lever 9, adjustable rod *d*, and lever 3, the object being to firmly hold the last under the toe and heel downholds by the action of the operating-lever 3.

Attached to the ends of the fingers is the girth G, which is elastic in itself in desired areas, (the girth shown in Fig. 11 possessing an elastic center,) or may be inelastic in itself and derive its elasticity from springs. In Fig. 3 is shown an inelastic girth, G', and spring *e*. The spring is fastened to the frame of the machine and to the bottom of the girth, and the girth may be continuous, as shown, or it may be parted along its center, and have each end attached to springs. This construction is shown in Fig. 13.

The principle illustrated by this inelastic girth and spring arrangement is the bringing of a compression and strain upon the upper along a line somewhat remote from the edge of the insole or bottom of the last, and to fit the upper to the last by continuing the strain and compression from that line to the edge of the insole. This result may be reached also by causing a frictional surface to act from a line sufficiently remote from the surface of the insole, and causing that surface to conform to the contour of the last to the surface of the insole. This last method, however, I intend to embody in a separate application.

I prefer that the contacting portion of the girth shall be wholly, or in part, provided with a frictional or roughened surface, which may or may not be of an elastic nature. One side of the girth in Fig. 9 is represented with a frictional surface, *f*.

The girth is secured to the ends of the fingers by the straps H, which must be flexible, and may be of a tougher nature than the material used in the construction of the girth.

The operation of the machine is as follows: The last, with the upper and insole adjusted

thereon, is hung upon the spindle with its heel and toe under the downholds. The jaws are then actuated outward, tightening the girth, and causing it to act from the center line, from instep to toe, or from lines adjacent thereto, and by the rising of the jaws, and the subsequent closing, the straining and compression action is exerted over the entire surface of the sides of the last to the surface of the insole, and the surplus, together with the margin of the upper, folded upon the insole. The toe and heel slides are then driven upon the insole, lasting the toe and heel.

If the shank-fingers are provided with the transverse movement on the jaws, it is desirable to operate them while the jaws are lifting.

It will be observed that the fingers which swivel shut upon the insole at, or nearly at, right angles to the line of the curvature of the sole edge, as shown in Fig. 6.

Having thus fully described my invention, I claim and desire to secure by Letters Patent—

1. In a machine for lasting the uppers of boots and shoes, the combination of the jaws A with the swiveling-fingers B, substantially as and for the purpose described.
2. In a machine for lasting the uppers of boots and shoes, the combination of the jaws A with pivoted adjustable fingers B, arranged as to height only upon the jaws to correspond to the curvature of a last's bottom, substantially as shown and described.
3. In a machine for lasting the uppers of boots and shoes, the combination of the jaws A with the fingers B', having an independent transverse movement, substantially as described, for the purpose set forth.
4. In a machine for lasting the uppers of boots and shoes, the combination of the jaws A with two or more pairs of fixed fingers and one or more pairs of swiveling fingers, arranged to operate substantially as described.
5. In a machine for lasting the uppers of boots and shoes, the combination of two or more pairs of fixed fingers and one or more pairs of fingers having an independent transverse motion effected by mechanism, substantially as described, with the jaws A, for the purpose set forth.
6. In a machine for lasting the uppers of boots and shoes, the combination of one or more pairs of fixed fingers, one or more pairs of swiveling-fingers, and one or more pairs of fingers having an independent transverse movement, with the jaws A, substantially as set forth.
7. In a machine for lasting the uppers of boots and shoes, the removable fingers B, in combination with the jaws A, the fingers being interchangeable thereon, substantially as and for the purpose described.
8. In a lasting-machine, the combination of the jaws A, the vertically-adjustable fingers B, and the girth G, substantially as and for the purpose set forth.

9. In a lasting-machine, the combination of two parallel jaws, A, removable fingers B, and girth G, substantially as set forth, and for the purpose described.

10. In a lasting-machine for lasting the uppers of boots and shoes, the combination of the jaws A and removable fingers B with a toe-and-heel-lasting mechanism, adjustable to and from the spindle between the jaws, substantially as described.

11. In a lasting-machine for lasting the uppers of boots and shoes, the fingers B, having a clamp to hold the girth, and provided with the pivots *a*, substantially as described.

12. In a lasting-machine for lasting the uppers of boots and shoes, the jaw A, having upward and a closing motion relative to the last, in combination with a girth possessing elasticity, substantially as and for the purpose described.

13. In a lasting-machine, the combination of the jaws A, inelastic girth G', and spring *e*, substantially as described, for the purpose set forth.

14. In a lasting-machine for lasting the uppers of boots and shoes, the combination of a jointed spindle, 7, lever 8, adjustable rod *d*, and operating-lever 3, all operating substantially as and for the purpose described.

15. In a lasting-machine for lasting the uppers of boots and shoes, a lasting-girth, provided with a roughened frictional inner surface, substantially as and the purpose described.

16. In a lasting-machine for lasting the uppers of boots and shoes, a lasting-girth, consisting of an inelastic flexible base and an elastic contacting inner surface, substantially as described.

17. In a lasting-machine for lasting the uppers of boots and shoes, the combination of two jaws, A, provided with fingers, girth G, and toe-and-heel-lasting mechanism, substantially as and for the purpose described.

GEO. W. COPELAND.

Witnesses:

FREE. F. RAYMOND,
ADOLPH J. OTTINGER.