

F. KAHL.  
PUMPS.

No. 182,582.

Patented Sept. 26, 1876.

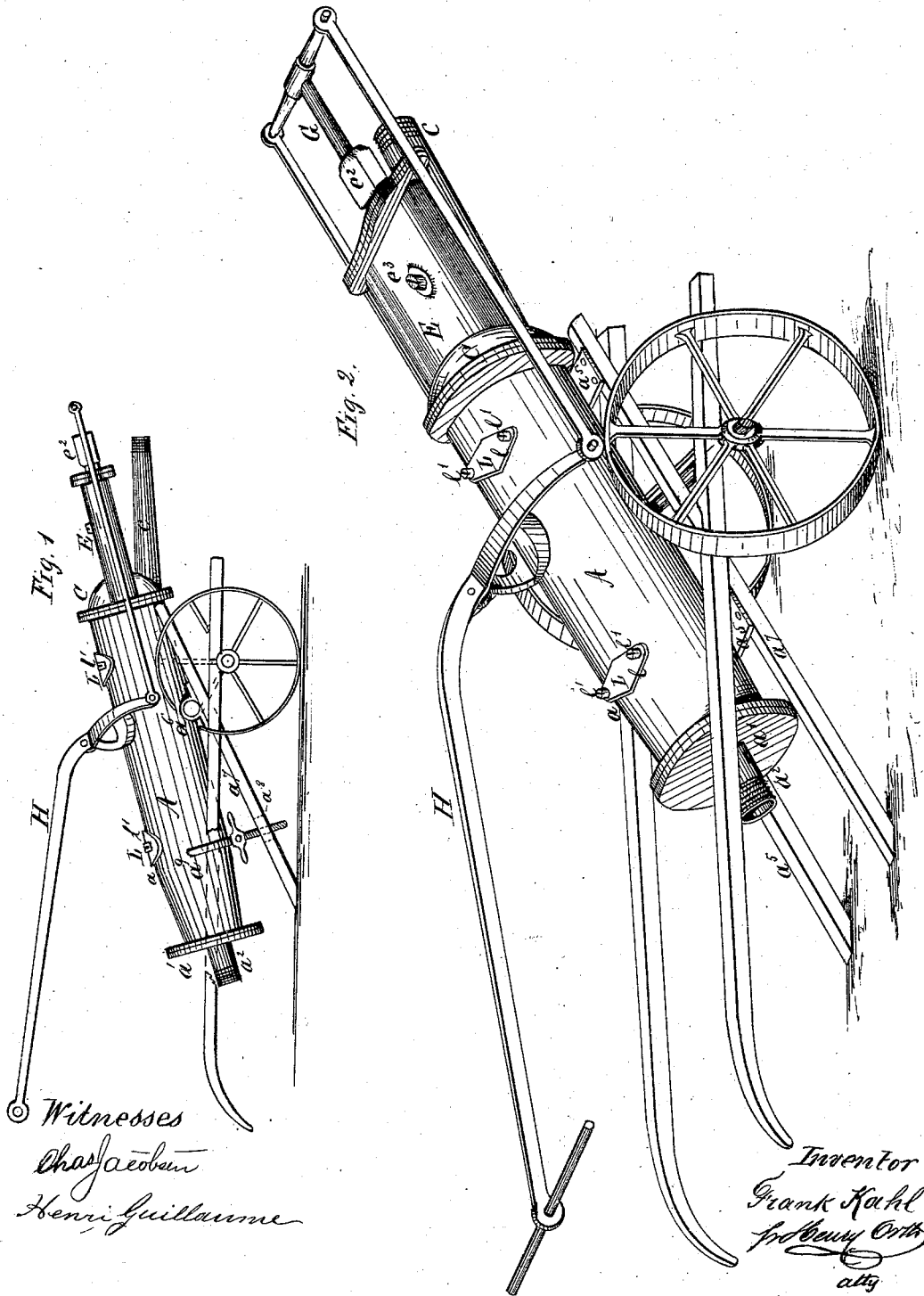

Witnesses  
*Charles Jacobson*  
*Henri Guillaume*

Inventor  
*Frank Kahl*  
*John Henry Orth*  
*att'y*

F. KAHL.  
PUMPS.

Patented Sept. 26, 1876.

No. 182,582.

Fig. 5.

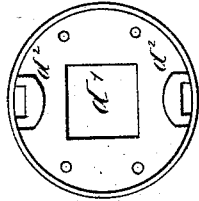
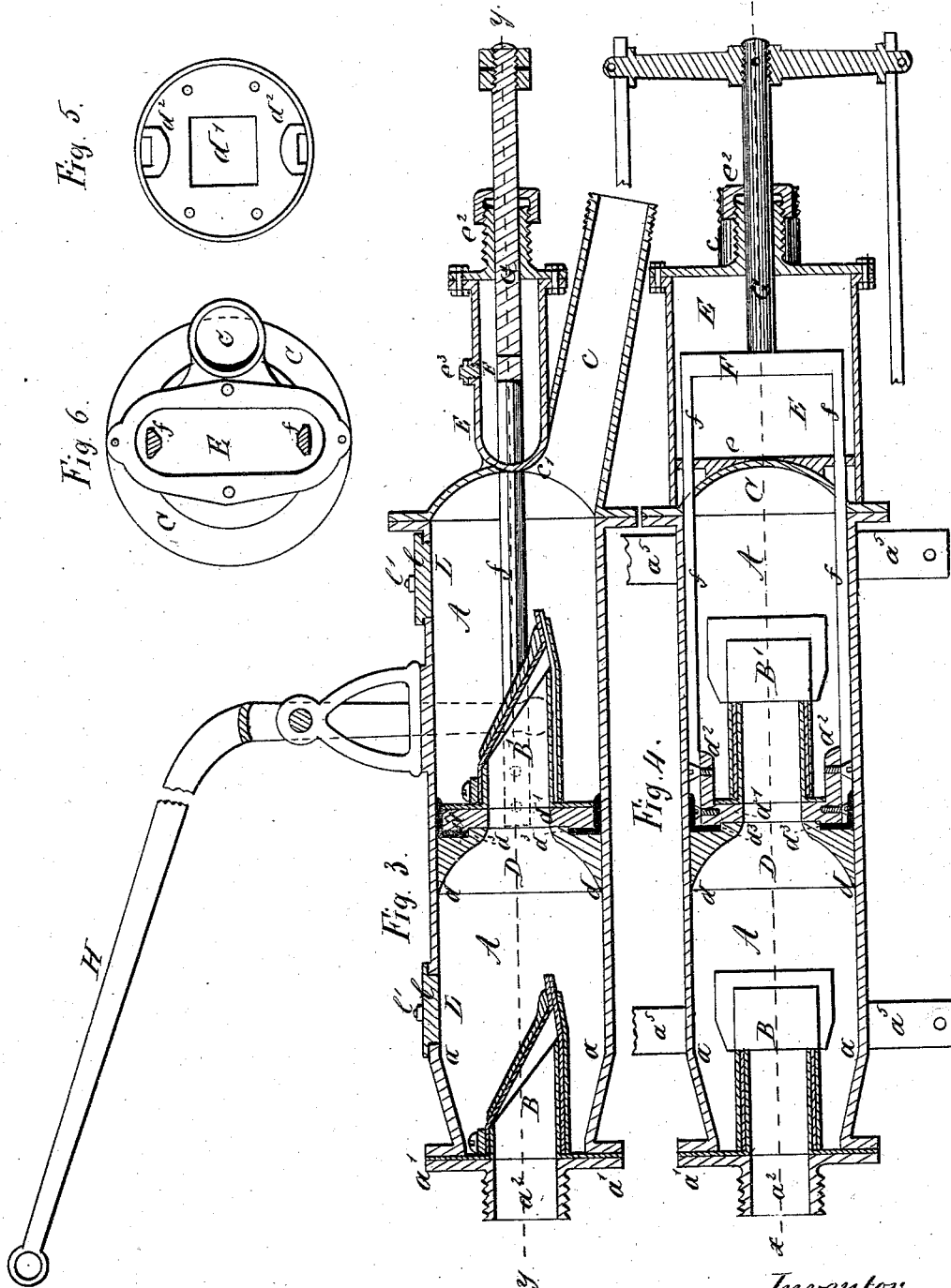
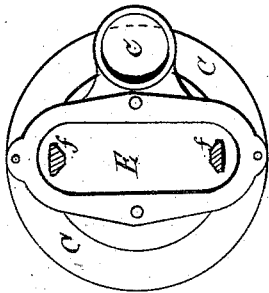

Fig. 6.



Witnesses.  
Henri Guillaume  
Chas Jacobus

Inventor.  
Frank Kahl  
by Henry Orth  
att'y.

# UNITED STATES PATENT OFFICE.

FRANK KAHL, OF RICHMOND, VIRGINIA.

## IMPROVEMENT IN PUMPS.

Specification forming part of Letters Patent No. 182,582, dated September 26, 1876; application filed March 6, 1876.

### *To all whom it may concern:*

Be it known that I, FRANK KAHL, of the city of Richmond, in the county of Henrico and State of Virginia, have invented certain new and useful Improvements in Pumps, of which the following is a specification:

My invention relates to that class of pumps particularly applicable for the pumping of semi-fluid or viscous matter, such as the contents of sinks, cess-pools, or privy-vaults, in which solid and gritty substances, such as wood, rags, coal, ashes, &c., are encountered, though the pump may be employed equally as well for the pumping of any other liquid.

Pumps of this character, as constructed heretofore, have all proved more or less unsatisfactory and defective in their operation, which arises from various causes. The principal ones, however, may be briefly enumerated as follows:

First, the choking of the barrel by solid substances, such as rags, sticks of wood, &c., which become lodged or wedged therein after leaving the induction-valve on their way to the piston-valve, or after leaving the latter on their way to the eduction-nozzle, either by reason of the shoulders formed by the piston around the inner walls of the pump, or by reason of the difference in the diameter of the barrel above the piston, such difference being caused by side chambers or similar devices, which form abrupt angles against which such solid substances abut and lodge, and consequently choke up the barrel; or this may occur in pumps of this character where any space whatever is left between the walls of the barrel and the pump-rods to enable solid substances to lodge between such rods and the walls, or permit rags to wind around said rods, which is frequently the case.

Second, the choking and the consequent frequent bursting of the hose by substances as above enumerated, which have not had time to become straightened after leaving the piston-valve and before reaching the hose.

Third, the leakage, almost constant (and which is obvious to any casual observer) at the several stuffing-boxes, by reason of their being in immediate communication with the interior of the barrel, and which is caused by the attrition of the gritty matter, such as sand,

ashes, &c., carried along by the pump-rods, and which causes these leakages after a few operations, necessitating constant attention and repair; and, lastly, the trouble and nauseating operation of taking the pump to pieces whenever it becomes choked, or for other causes, necessitating frequently the removal of both heads to clear the barrel or the valves of obstructions, or for inspection of the latter.

To obviate and remedy the difficulties above enumerated, my invention consists, first, in forming the pump-barrel, from a point near the eduction-orifice of the induction-valve to the eduction-nozzle, of equal diameter, so as to produce a smooth unbroken line for the passage of the semi-fluid matter and the solid substances which may be mixed therewith.

Second, in constructing the piston in such a manner that its circumference at the induction-port shall form a knife-edge working in frictional contact with the interior wall of the barrel, the inner circumference of said induction-port being bell-mouthed or conical, thus forming an easy passage to the induction-port of the valve carried by said piston, and also to avoid a circumferential shoulder or projection, against which solid substances can lodge, and by reason of the curvature of the induction-port of the piston any solid substance of any length is straightened with the current before reaching the induction-port of the valve.

Third, in connecting the arms or shanks of the bail to the periphery of the piston-head, so that they shall work on a line with the center or axis of the barrel, and practically in frictional contact with its interior walls, said arms or shanks being constructed in the form of a truncated triangle in cross-section, having their base or their broad face made to fit the inner wall of the barrel; or, in other words, the broad face in contact with the walls of the barrel is curved so as to correspond exactly to that portion of the arc described by the interior wall of the barrel where said shanks are located.

Fourth, in contracting the diameter of the barrel below or behind the eduction-orifice of the induction-valve, for the purpose of reducing what is ordinarily called the "dead-water area," which, in pumps of this character, is

necessarily great by reason of the peculiar construction and length of the valves necessary for this kind of service.

Fifth, in the construction of a water-chamber, by means of which the working parts of the pump are isolated from the pump-barrel, and so arranged that but one outer stuffing-box is needed, which is not in immediate communication with, but entirely isolated from, the viscous matter, so that all danger of nauseating leakages is avoided.

Sixth, in providing the eduction-head with a long, or comparatively long, eduction-nozzle, whose axis shall lie at an angle to the axis of the pump-barrel, the eduction-head being conical or dome-shaped, the walls of the eduction-nozzle forming practically a continuation of the curve of the head, for the purpose of forming an easy outlet for the matter, and also to enable solid substances of any length to become straightened with the current before reaching the hose; and, by forming the eduction-nozzle at an angle to the axis of the pump, the latter may be worked when either in a horizontal or inclined position.

Seventh, in the peculiar construction of the eduction-head and water-chamber, whereby small chambers are formed, through which the arms of the bail pass into the pump-barrel, and which serve as stuffing-boxes to receive metallic linings.

Eighth, in providing hand-holes for the purpose of inspecting the interior mechanism of the pump at any time without removing either of the heads.

But that my invention may be fully understood, I will proceed to describe the same in detail by aid of the accompanying drawings, in which—

Figures 1 and 2 are an elevation and a perspective view, showing the manner of mounting the pump. Fig. 3 is a section of the pump through line  $xx$  of Fig. 4. Fig. 4 is a similar view through line  $yy$  of Fig. 3. Fig. 5 is plan view of the cylinder-head, and Fig. 6 is a similar view of the eduction-head and water-chamber with the top removed.

The pump may be mounted on an ordinary baggage-truck or other truck, as shown by Fig. 2, and for this purpose the barrel is provided with transverse supporting plates or feet  $a^5$ , through I prefer to mount it, as shown by Fig. 1, on trunnions formed or affixed to the barrel. These trunnions  $a^6$  have their bearings either on the axle itself or on the two parallel side pieces or cheeks  $a^7 a^7$ , the end of the pump resting on a transverse bar,  $a^8$ . I prefer this mode of mounting for the reason that the pump may be worked with greater advantage in a horizontal position, or even in a position with the eduction-nozzle depressed, in localities where the receiving tank or barrel cannot be brought in close proximity to the pump, and consequently where a considerable length of eduction-hose has to be used, which may then be allowed to lie on the ground or floor. This is especially the case in densely built up

cities. Another advantage in mounting the pump on trunnions and employing suitable mechanism to elevate or depress its rear end—consequently depress or elevate the eduction-nozzle—is that the angle of inclination of the pump may then be regulated at will, or to suit the particular locality where it has to be employed; and to that effect I employ the ordinary mechanism adapted to ordnance, the screw, however, being provided with a half-collar,  $a^9$ , in which the rear end of the pump-barrel rests so as to give it a firm bearing, though the collar may be dispensed with.

A represents the barrel of the pump, of an equal interior diameter from a point,  $a$ , beyond or behind the eduction-orifice or mouth of the induction-valve B to the eduction-head or bonnet of the barrel. From the point  $a$  to the opposite end or induction-head  $a^1$  the barrel is made tapering or conical—that is to say, its interior diameter is contracted gradually from the point  $a$  to the extremity  $a^1$ , in order to reduce what is commonly called the “dead-water area,” which in pumps of this character is necessarily much greater than the area would be in a pump for pumping pure liquids, by reason of the length and peculiar character of the valves employed.

This reduction of the dead-water area or chamber is of importance, as it will not admit of sufficient quantities of solid matter to impair the functions of the valve, the matter being passed through the pump with greater facility than it would be if the interior diameter behind said valve were equal to the interior diameter of the pump. The induction-head and valve B are connected to the barrel of the pump in any approved or preferred manner, and the former is provided with an induction-nozzle,  $a^2$ , to which an induction-hose may be coupled in the usual manner. C is the eduction-head or bonnet, which is dome-shaped or conical, as shown by the drawings, and has a water-chamber, E, of elliptical or nearly elliptical shape, bolted or otherwise affixed thereto, or formed thereon, for the purpose of receiving the bail or yoke F, and its connections, to isolate them from contact with the viscous matter. (More fully explained hereinafter.) The back wall or floor  $e$  of said chamber is perfectly horizontal or level, so that when in position on the dome of the eduction-head said back wall  $e$  and the outer face of the dome will form chambers  $e^1$  between them, through which pass the shanks or arms  $f$  of the yoke or bail F, the back wall of said chamber, and the dome of the bonnet having suitable apertures formed therein for the purpose, thus forming stuffing-boxes to receive metallic lining or packing, or other suitable packing completely isolated from the exterior of the pump by the intervening chamber E, and the only stuffing-boxes in direct communication with the interior of the barrel. Hence, should a leakage occur, the viscous matter could never find its way to the exterior of the pump, and cause nauseous emanations during

the operation. This arrangement and construction are clearly shown by Fig. 4.

The head C is further provided with a long eduction-nozzle, *c*, whose axis lies at an angle to the axis of the pump-barrel, for permitting egress to the matter with equal facility, whether the pump is worked in a horizontal or inclined position.

The eduction-orifice from a point, *c'*, of the dome curve is constructed so as to form, practically, a continuation of said curve—that is to say, the edges of the orifice are not abrupt, but form a natural and easy curve into the nozzle *c*, which is gradually contracted toward its outer end, which latter is provided with the necessary means to couple a hose thereto, as fully shown by Fig. 3.

By giving the interior wall of the head C a dome shape, and by giving the curvature to the entrance into the nozzle, no shoulder or abrupt projection or angle is left, against which solid substances may lodge; but, on the contrary, the nature of the curvature will lead or guide such solid substances into the nozzle, and by giving the latter increased length and slight taper such substances, when of any length, will become straightened before reaching the eduction-hose. Therefore, should by any means an obstruction occur, this would necessarily take place in the eduction-nozzle, and thereby all danger of bursting of the hose is avoided.

D is the piston, the interior surface of its induction-port being bell-mouthed and tapering down to a knife-edge, as shown at *d*, Figs. 3 and 4, the said interior surface forming a gradual and easy curve toward the induction-port of the valve B'. By this means there is no circumferential shoulder formed by said piston of sufficient thickness to admit of any solid substance lodging against it and impairing its functions.

The nature of the curvature of the inner face of the induction-port of said piston will guide the semi-fluid matter to the valve, and also straighten any solid substance before entering said valve, thus obviating and effectually guarding against the choking of said valve. The piston D works in frictional contact with the walls of the barrel, and is provided with a shoulder, *d*<sup>3</sup>, fitting into a corresponding depression formed in the head *d*<sup>1</sup>, thus forming a circumferential ledge or recess between said piston D and head *d*<sup>1</sup>, for the reception of the ordinary cup or other preferred packing, which is secured in position by any usual or preferred means.

The induction-head and piston are each provided with one of my improved valves B B', for which I obtained Letters Patent under date of January 4, 1876, No. 171,817, and need, therefore, no further description here, though any other preferred valves may be employed.

F is the bail or yoke, to which the main pump-rod G is connected, or formed thereon, said bail being provided with two arms or shanks, *f f*, connected to the periphery of the

piston-head *d*<sup>1</sup> either by dovetailing or by recessing said piston-head, or in any other suitable manner, so that their outer faces shall be flush with the periphery of said head, which may be provided with vertical recessed shoulders or ears *d*<sup>2</sup>, to which the arms *f* may be bolted, as shown by Fig. 4.

Instead of employing the ordinary round rods I employ truncated triangular rods or shanks, their broadest outer face being curved to fit the interior wall of the barrel, and thus work practically in frictional contact with said interior wall.

The advantages of this construction are obvious, and consist as follows: First, the space occupied by such rods is considerably diminished, as they project but very little toward the axis of the barrel; secondly, their broad face in close contact with the walls of the barrel prevents any solid substance, such as wood, and especially rags and straw, to get between them and the wall of the barrel, and by the motions of the shanks become wound around the latter, as is frequently the case in pumps of this character, when the ordinary round rod is employed; and, lastly, shanks of greater strength and smaller diameter can be employed, as in the case of round rods, which, at all events, owing to their configuration, will leave a wedge-shaped recess between themselves and the walls of the barrels, no matter how closely such round rods may be located to said interior walls.

The yoke or bail F is located in the water-chamber E of the bonnet or eduction-head C, and its arms pass down into the barrel of the pump through the chambers *e*<sup>1</sup>, formed by the bottom or floor *e* of said chamber, with the outer face of the dome of the head C, as above described, and the main rod G passes out through a stuffing-box, *e*<sup>2</sup>, formed on the water-chamber E in such a position that said rod will lie in the line of the axis of the barrel A, and work centrally, while the shanks of the bail are connected to the periphery of the piston-head on opposite sides thereof, in a line parallel with the axis of the barrel. The rod G has the ordinary connections, and is operated by a forked brake, H, as shown by Fig. 1.

When the pump is started for operation the chamber E is filled with water, said chamber being provided with a screw-plug, *e*<sup>3</sup>, or cock or equivalent device for filling the same, and when desired the water is again removed by a pet-cock or screw-plug, (not shown in the drawings,) with which the chamber E is provided.

To further guard against noxious leakage, the water may be disinfected by mixing therewith any of the well-known disinfectants.

It will be obvious that by this arrangement of water-chamber and stuffing-boxes *e* a noxious leakage at the outer stuffing-box *e*<sup>2</sup> is impossible, or nearly so, and the wear of the latter is comparatively small—not more than in ordinary pumps—as no gritty matter, such as

ashes or sand, can be carried into said stuffing-box.

I have here described a water-chamber having one outer stuffing-box,  $e^2$ , though it is obvious that the same result—absence of nauseating leakages—may be attained by forming two chambers, one for each arm of the bail F. This necessarily requires two outer stuffing-boxes instead of one, as above described; but in this case one single brake-lever, to operate the pump, may be employed, or the forked lever, if preferred.

Of course it will be understood that when two chambers are employed each will be provided with the necessary means for filling the same with water, and for emptying the chambers when required.

In order to afford ready access to the interior of the barrel, I provide two hand-holes, L, one above the induction-valve, and the other above the limit of the downward stroke of the piston. Their covers or plugs are secured in position in any suitable manner, though in pumps of this character I prefer to secure them by means of bolts  $V$ , as shown. The lower faces of these plugs or covers are flush with the interior wall of the pump-barrel, and are slightly curved, so as to form practically a part and portion of said barrel, and thus form no shoulders or other irregularity in the inner configuration of the walls, to obstruct in any manner the passage of the matter.

The valves B B' are connected to the induction-head and piston in such manner that their ports will lie in the line of the axis of the pump-barrel, to facilitate the passage through the latter to the eduction-nozzle.

Instead of forming the water-chamber E elliptical or elongated in shape it may be formed tubular, and when two chambers, one to each shank of the bail, are employed, I prefer the tubular form.

Having now described my invention, what I claim, and desire to secure by Letters Patent, is—

1. A pump-barrel having its interior of equal diameter from a point slightly in rear of the eduction port or mouth of the induction-valve to the bonnet or cap of the barrel, and its lower interior portion behind said point tapering or decreasing in diameter, for the purpose of reducing the dead-water area, and produce an unobstructed and smooth interior surface throughout the length of the barrel, substantially as described, for the purpose specified.

2. In combination with the hand-holes of a pump-barrel, the covers or plugs so constructed that their inner or lower surface shall be flush with, and of the configuration of, the interior wall of the barrel, so as to form practically a part and portion of said interior wall of the barrel, substantially as described, for the purpose set forth.

3. In a pump especially adapted for the pumping of semi-fluid or viscous matter, as set forth, the combination, with the barrel of

the pump, of an eduction-nozzle of comparatively great length, so constructed that its axis shall lie at angle to the axis of the barrel, substantially as described, and for the purpose specified.

4. In a pump, the combination, with the barrel and cap or bonnet, of a water chamber or chambers, to receive the yoke or bail and its connections, substantially as described, and for the purpose set forth.

5. The combination of a dome-shaped head or bonnet of a pump-barrel with a water chamber or chambers, so connected that the bottom or back wall of said chamber or chambers shall form receptacles or chambers, or stuffing-boxes  $e^1$ , for the passage of the arms of the bail into the barrel, said dome and bottom or back walls being provided with suitable apertures for the purpose, substantially as described, for the purpose specified.

6. The combination, with the water chamber or chambers, of the stuffing-boxes  $e^1$   $e^2$ , and suitable screw-plugs and pet-cocks, or their equivalent, as and for the purpose set forth.

7. In a pump, the piston having its induction-port formed bell-mouthed, and the edges thereof tapered to a knife-edge, or practically so, and having a circumferential flange or shoulder,  $d$ , in combination with a piston-head,  $d^1$ , having a corresponding circumferential shoulder or offset to fit the depression in the piston, substantially as described, and for the purpose set forth.

8. The combination, with the pump-barrel, of a piston and piston-head, and the arms of a bail or yoke, said arms being connected to the periphery of the piston-head on opposite sides, and on a line parallel with the axis of said pump-barrel, in such manner as to work in frictional contact, or practically so, with the interior walls of said barrel, substantially as described, and for the purpose set forth.

9. The combination, with a pump-barrel, of a piston, constructed as described, and a recessed piston-head, and the arms or shanks of a bail, said arms or shanks being of a truncated triangular shape in cross-section, and having their outer or broadest surface convex to fit the concave surface of the interior wall of the barrel, substantially as described, and for the purpose specified.

10. The combination, with the piston of a pump, constructed as described, of the piston-head, having vertical recessed shoulders or ears, to receive the angular-shaped arms of the bail upon its periphery, so that said arms shall be flush with the latter, and practically in frictional contact with the interior walls of the pump-barrel, as described, and for the purpose specified.

11. In a pump for pumping viscous or semi-fluid matter, as set forth, the combination of the barrel, the dome-shaped head, the water-chamber, the stuffing-boxes  $e^1$   $e^2$ , and the elongated eduction-nozzle, with the piston, the bail and bail-arms, and the pump-rod, substantially as described, for the purpose set forth.

12. A pump, the barrel of which is provided with trunnions, and mounted on a hand or other truck, in combination with suitable mechanism for raising or depressing its induction or lower end to work the pump either in a horizontal position or at any inclination required or desired, substantially as set forth.

In witness that I claim the foregoing I have hereunto set my hand this 29th day of February, 1876.

FRANK KAHL.

Witnesses:

CHAS. A. HENNIGHAUSEN,  
CHAS. LUNDIN.