

J. R. TEASS.

APPARATUS FOR HANDLING AND TRANSFERRING HIDES DURING THE TANNING PROCESS.

No. 182,614.

Patented Sept. 26, 1876.

Fig. 1.

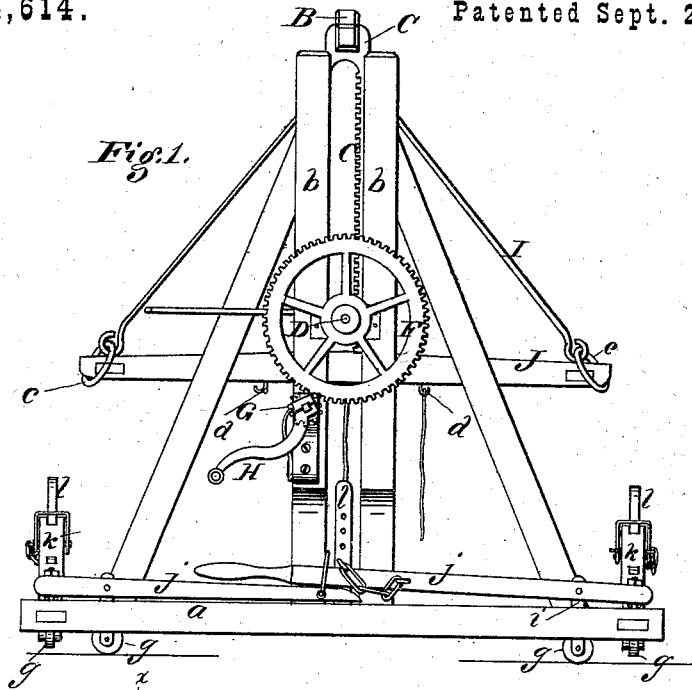
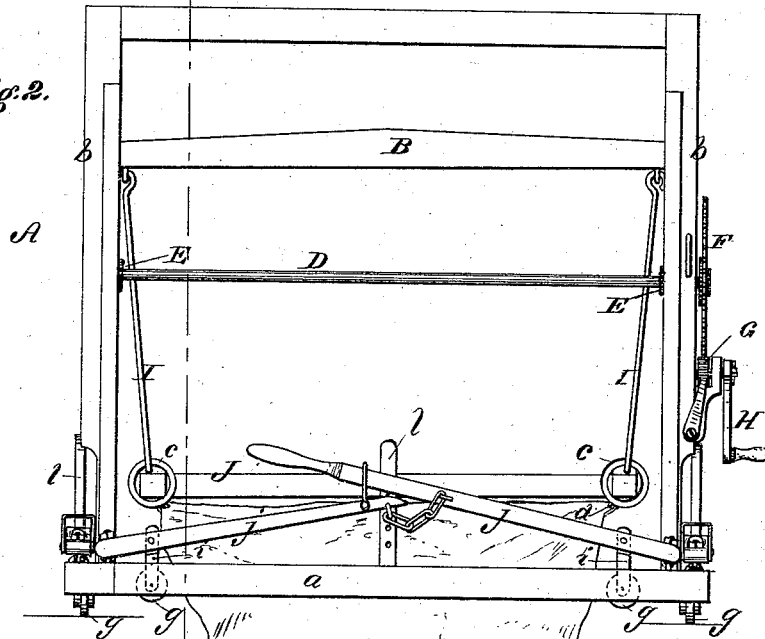

Fig. 2.



Witnesses:  
 Donat S. Twitchell  
 Will H. Dodge.

Inventor:  
 J. R. Teass.  
 By his attys.  
 Dodge & Sons

J. R. TEASS.

APPARATUS FOR HANDLING AND TRANSFERRING HIDES DURING THE TANNING PROCESS.

No. 182,614.

Patented Sept. 26, 1876.

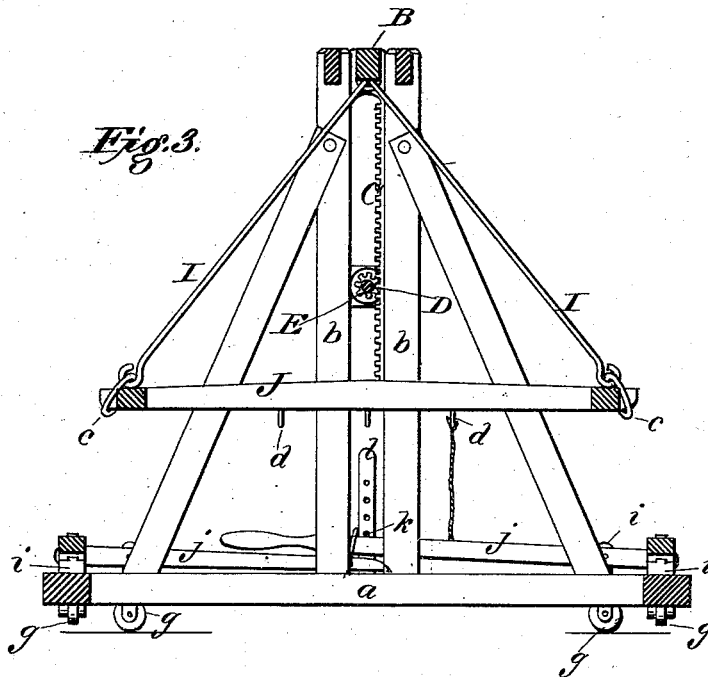

*Witnesses:*  
*Down S. Twitchell,*  
*Will H. Godge.*

*Inventor:*  
*J. R. Teas,*  
*By his attys*  
*Dodges & Son*

# UNITED STATES PATENT OFFICE.

JOHN R. TEASS, OF ST. ALBANS, WEST VIRGINIA.

## IMPROVEMENT IN APPARATUS FOR HANDLING AND TRANSFERRING HIDES DURING THE TANNING PROCESS.

Specification forming part of Letters Patent No. **182,614**, dated September 26, 1876; application filed July 19, 1876.

*To all whom it may concern:*

Be it known that I, JOHN R. TEASS, of St. Albans, in the county of Kanawha and State of West Virginia, have invented certain Improvements in Carriages for Handling and Transferring Hides in Tanneries, of which the following is a specification:

My invention consists in certain improvements in the construction of the carriages employed for lowering hides into and removing them from tan-vats, and transferring them from place to place, as hereinafter described.

Figure 1 represents an end elevation of my improved carriage; Fig. 2, a side elevation of the same; Fig. 3, a vertical transverse section of the same.

A represents the main frame of the carriage, consisting of a rectangular base-frame, *a*, provided at each end with a pair of parallel uprights or guide-posts, *b*. B represents a horizontal beam extending from end to end of the frame, with its ends mounted loosely between the uprights *b*, and secured to vertically-sliding rack-bars C, which are mounted in grooves in the uprights, as shown. D represents a longitudinal shaft mounted in bearings attached to the standards, and provided at its ends with pinions E, which gear into the rack-bars C, for the purpose of moving the same vertically, and thereby raising and lowering the beam B. At one end the shaft D is provided, as shown, with a wheel, F, gearing into a pinion, G, attached to the frame, and provided with a hand-crank, H, by means of which the parts are operated. The beam B is provided at each end with two hanging rods, I, provided at their lower ends with large rings *c*, to receive and sustain the corners of the horizontal frame J, to which the hides are attached. The frame J is made in a rectangular form and secured rigidly together, and is provided at its ends with hooks *d*, to receive and hold the upper corners of the hides.

By the use of the rigid frame having the suspending-hooks for the hides secured thereto, the machine is adapted for receiving a large number of hides, and keeping them at even and regular distances apart, and by suspending the frame in the manner shown it

can be readily attached to or detached from the carriage, and thereby the entire load of hides taken up or set down, as required.

By suspending the frame by the rods from a single beam, as shown, the frame is permitted to retain a horizontal position, notwithstanding the tipping of the carriage, so that in moving the carriage over uneven ground and in lowering the hides into vats on a hill-side, as is sometimes required, they are permitted to retain their vertical positions, and are not caused to come in contact with each other, so as to endanger their adherence one to another.

In order that the carriage may be readily moved about in all directions, and that it may at the same time be caused to rest firmly in place when desired, whether on a level or an inclined track, it is provided with two sets of adjustable wheels at right angles to each other.

As shown in the drawings, the wheels *g* are mounted in the lower ends of vertical slides *i*, the upper ends of which are secured to levers *j*, which latter are mounted on the main frame and fastened by means of pins *k* passed through vertical posts *l*, which extend up through the free ends of the levers.

By means of the levers both sets of wheels may be raised out of action, and the frame thereby permitted to seat itself solidly and firmly in place; or either set of wheels depressed and thrown into action, according to the direction in which the carriage is to be moved.

I am aware that a carriage having one set of fixed wheels has been provided with another set of adjustable wheels; but, in practice, it is often found desirable to have the carriage seated solidly in position, and hence the importance of using the two sets of adjustable rolls.

I am also aware that a carriage has been hitherto constructed in which cross-heads to sustain hide-supporting bars have been elevated by means of screws; but, in practice, the arrangement is found useless, for the reason that, being subjected to the weather, and to the various corroding liquids and substances employed in the tannery, the screws are soon rendered inoperative. The rack-bars

and pinions also have the advantage of being cheaper than the screws, of permitting a quicker movement of the parts, and of avoiding the use of the extra pinions required to operate the screws.

Having described my invention, what I claim is—

The combination of the wheeled frame A,

provided with the shaft D, having the pinions E, and the beam B, provided with the rack-bars C, and the suspending-rods I, as shown.

JOHN R. TEASS.

Witnesses:

C. E. GRIFFITH,  
N. B. BROOKS.