

N. N. HORTON.
RECLINING CHAIR.

No. 182,671.

Patented Sept. 26, 1876.

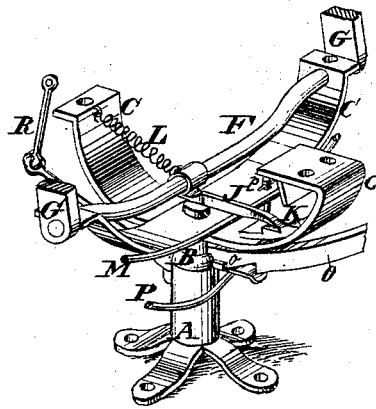
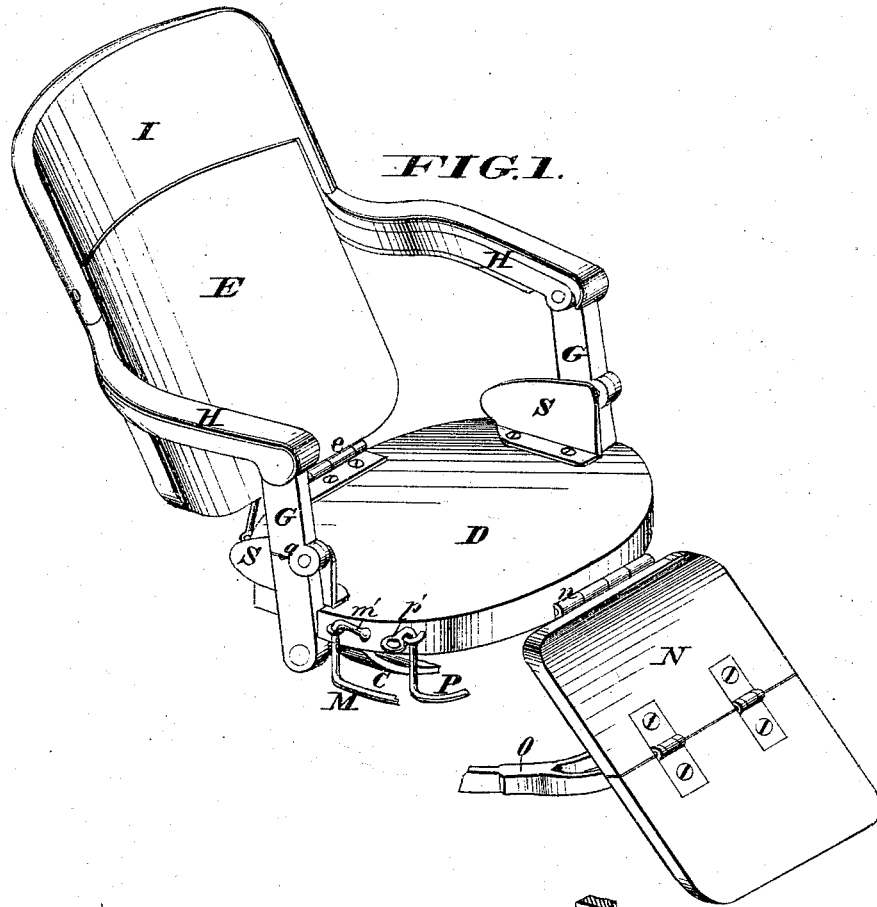

WITNESSES

Chas. Goehs
LeBlond Burdett

INVENTOR

N. N. Horton
By Knightrich, Attorneys

N. N. HORTON.
RECLINING CHAIR.

No. 182,671.

Patented Sept. 26, 1876.

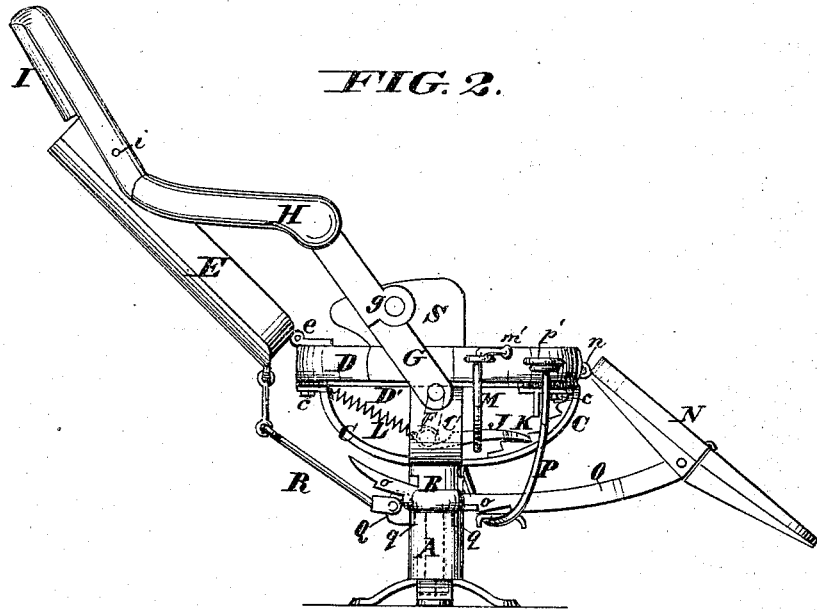

FIG. 2.

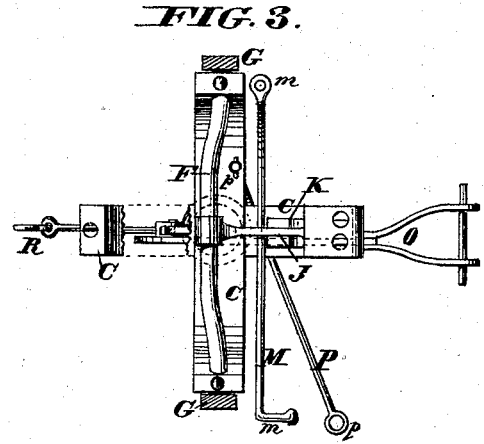

FIG. 3.

WITNESSES
Chas Gooch
Le Blond Burdett

INVENTOR
N. N. Horton
 By *Knight & Sons* Attorneys

UNITED STATES PATENT OFFICE.

NUMON N. HORTON, OF KANSAS CITY, MISSOURI.

IMPROVEMENT IN RECLINING-CHAIRS.

Specification forming part of Letters Patent No. 182,671, dated September 26, 1876; application filed April 19, 1876.

To all whom it may concern:

Be it known that I, NUMON N. HORTON, M. D., of Kansas City, in the county of Jackson and State of Missouri, have invented a certain new and useful Improvement in Reclining-Chairs, of which the following is a specification:

My improved car-seat is constructed to adapt it for use either as a day-chair or a reclining-chair, the hinged back being arranged to tip forward, so that the chair may turn on a swivel without occupying more space than the area of the seat. It is provided with a head-rest, attached to angular arms, which are pivoted to the back and to the upper ends of the arm-standards, so as to cause the head-rest to assume the plane of the back when the latter is nearly upright, and to project above its surface, to serve as a pillow when the back is lowered for reclining. For the tipping and inclining of the back the arm-standards are knuckle-jointed, and are connected to a bowed or crank-shaped pivot beneath the seat, which carries a pawl, engaging with a rack, to hold the back in any position, and retractable by a lever-arm, and provided with a spring, to keep the knuckle-joints of the standards closed, and counterbalance the back when inclined. The stationary foot forms a socket, within which is swiveled a supporting-frame, the main portion of which consists of a spider, with four arms secured to the bottom of the seat, and two of them forming bearings for the crank-pivot. Said spider also carries a stop-lock for securing the chair to face in either direction, said stop-lock being connected to the back, so as to be retracted when the back is tipped forward. The stem of the spider is slotted, to receive the toothed supporting-arm of the pivoted leg-rest, which arm is elevated by means of a lever, to permit the rest to fall.

In the accompanying drawing, Figure 1 is a perspective view of my improved chair, the seat and upper portions being removed from the supporting-frame, to exhibit the construction of the latter. Fig. 2 is a perspective view, taken from another point. Fig. 3 is a horizontal section underneath the seat.

A represents a cast-iron foot or base, intended to be permanently secured to the floor

of the car, and forming a socket for the reception of the pivot B of a cast-iron supporting-frame or spider, C, which may be secured by bolts *c* to a cast-iron ring or frame, D', on which the seat-bottom D is supported. F represents a crank or bow shaped lever, fitted to turn in suitable bearings in the spider C, and rigidly secured at its ends to standards G, which are formed at *g* with knuckle or rule joints, and are hinged at their upper ends to the arms H. The arms H are permanently connected to a head-rest, I, which is hinged at *i* to the back E. *e* represents the hinge which connects the back E to the seat D. To the center of the crank-lever F is applied a pawl, J, engaging with a ratchet-neck, K, on the spider C, so as to support the back in any position to which it may be adjusted. A strong spiral or other spring, L, connecting the center of the crank-pivot F with the rear part of the spider, supports the weight of the back, and tends to keep the knuckle-joints G of the standard closed. M represents a lever fulcrumed at *m*, and provided with a knob or ring, *m'*, within convenient reach of the occupant of the chair, for the purpose of raising the pawl J when the back is to be inclined. N represents a leg-rest, formed of two leaves hinged so as to fold together, and hinged at *n* to the front of the seat D. The leg-rest is supported by a hinged arm, O, fitted to slip within a slot in the stem of the spider C, and formed with ratchet-teeth *o*, which engage with a suitable tooth in front of said slot. P is a lever fulcrumed at *p*, and provided with a knob or ring, *p'*, in convenient reach of the occupant of the chair, for the purpose of raising the supporting-arm when the leg-rest is to be lowered to any extent desired.

The knuckle-joints *g*, in the standards G, are to permit the tipping forward of the back and the attached head-rest, so as to admit of turning the chair within a small space. To fix it parallel with the car and facing in either direction, the spider is provided with a falling-stop, Q, which drops into either notch *q* or *q'* in the foot A. The stop Q is connected by a rod or chain, R, to the seat-back E, so that the act of tipping the back forward will raise the stop and release the seat, to permit it to turn. S S are fenders, attached to the

sides of the seat, for the purpose of keeping the clothing of the occupant from contact with the moving standards G.

It will be observed that in this chair the arms and head-rest are made in one piece or permanently connected, so that they always retain the same relative angle with each other, whether the chair-back is inclined or not, and they are pivoted at such a point to the back as to afford a convenient head-rest or pillow for the head of the occupant while reclining, the said head-rest being produced automatically by the movement of the back itself. The turning of the head-rest from the plane of the chair-back when the passenger is reclining also affords more room for the occupant of the next seat behind.

The crank lever or pivot F is peculiar in its construction and operation. Its semicircular or bowed form downward beneath the seat gives a leverage to act with the pawl and rack in supporting the back in the position in which it may be set, and it is turned a little backward from the perpendicular, so as to give the strongest leverage when the back is most inclined, and, consequently, bears the heaviest strain. The bowed form of this lever-pivot also affords room for the springs and other parts of a properly-upholstered seat, permitting them to project below the plane of the seat-frame D.

The utility of the provision for tipping the back forward is apparent in view of the difficulty commonly experienced in turning high-back car-seats on pivots. Pivoted seats, as ordinarily constructed, require too large an area to turn in without interfering with each other; but by my improvement I produce a high-back chair which can be turned within the area of its seat or bottom. I am thus enabled to put high-back chairs close together side by side and reverse them when required with perfect ease.

The action of the spring L is to keep the stop or hinge-joint *g* of the standards always closed except when the back is set forward to turn on a pivot. This constant pulling of the spring on the crank-lever F, below the pivot, effectually prevents the flexure of the knuckle-

joints *g* when raising the back from an inclined position. It also balances the weight of the back when inclined. The stop-locks hold the chair in a position parallel with the car, and prevent its spontaneous turning or swinging on its pivot with the motion of the car, or from other causes.

Some portions of my invention are equally applicable to invalid and easy chairs for house use.

Having thus described my invention, the following is what I claim as new and desire to secure by Letters Patent:

1. The angular arms H and head-rest I rigidly connected together and hinged to the back E, in the manner and for the purpose set forth.

2. The bow-shaped crank-lever F in combination with the uprights G, back E, arms H, supporting-pawl J, and rack K, substantially as and for the purpose set forth.

3. The combination of the uprights G, constructed with knuckle-joints, and the hinged back E, and arms H, to provide for setting the back forward, in the manner and for the purpose set forth.

4. The combination of the back E, arms H, and jointed uprights G, and a suitable supporting-frame with the stop Q, so that said stop will be retracted by the tipping forward of said back, in the manner explained.

5. The combination of the hinged back E, arms H, uprights G, crank-lever F, supporting-pawl J, and lever M for retracting said pawl, as set forth.

6. The spider, having arms for attachment to the seat-frame D', and bearings for the shaft which forms the pivot of the uprights G, in the manner explained.

7. The leg-rest N in combination with the hinged supporting-arm O working in a slot in the stem of the spider C, and with the lever P for elevating said supporting-arm when the leg-rest is to be lowered, substantially as set forth.

N. N. HORTON, M. D.

Witnesses:

J. L. BARNES,
J. H. RIEGER.