

A. C. PRY.

DIAMOND MILLSTONE DRESSING MACHINES.

No. 182,706.

Patented Sept. 26, 1876.

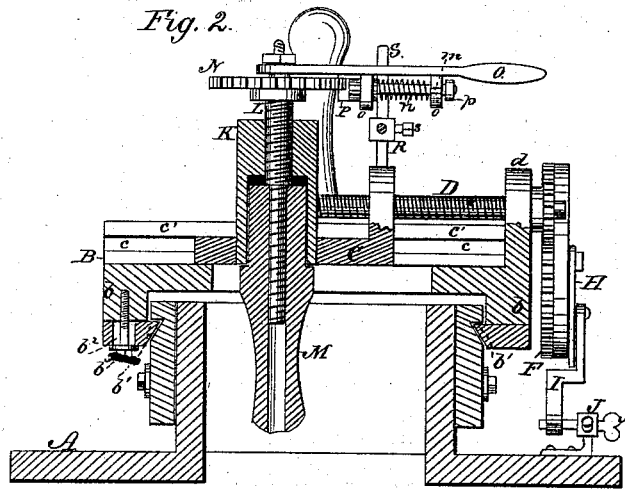
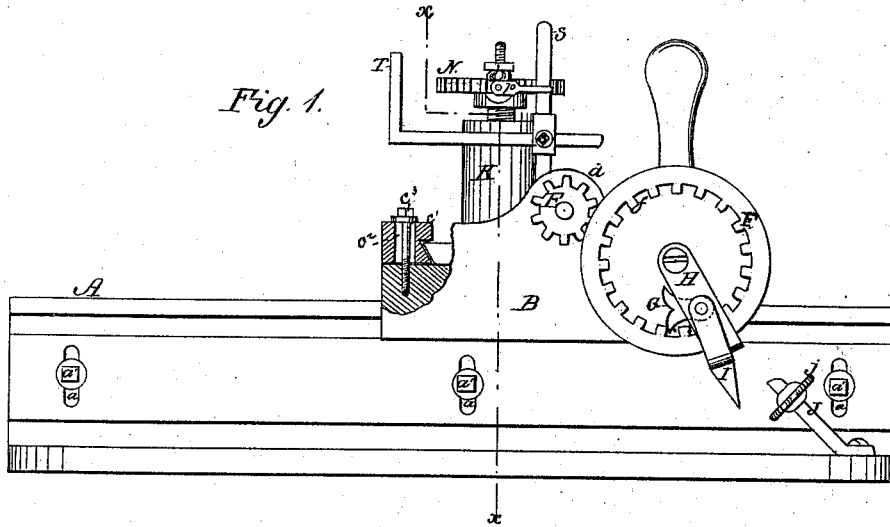

WITNESSES:

W. W. Hollingsworth
John A. Kemou

INVENTOR:

A. C. Pry
BY
Kenn & Co
ATTORNEYS.

UNITED STATES PATENT OFFICE.

AARON C. PRY, OF KEEDYSVILLE, MARYLAND.

IMPROVEMENT IN DIAMOND MILLSTONE-DRESSING MACHINES.

Specification forming part of Letters Patent No. 182,706, dated September 26, 1876; application filed August 24, 1876.

To all whom it may concern:

Be it known that I, AARON C. PRY, of Keedysville, in the county of Washington and State of Maryland, have invented a new and Improved Diamond Millstone-Dressing Machine; and I do hereby declare that the following is a full, clear, and exact description of the same, reference being had to the accompanying drawing, forming part of this specification, in which—

Figure 1 is a side elevation with part broken away. Fig. 2 is a cross-section on line *xx* of Fig. 1.

The object of my invention is the construction of a machine whereby millstones may be readily and quickly dressed by diamond tools; and it consists of a rectangular main frame to rest on the stone, over the top of which a carriage carrying the diamond cutter or tool slides longitudinally, and parallel with the face of the stone. The diamond is fixed or set in a vertical holder attached to the carriage, and made adjustable up or down by means of a central vertical screw, which is moved by a gear-wheel, sliding lever, and spring-pawl, in a manner hereinafter more fully described.

The tool is adjusted laterally by causing the rectangular piece, to which the tool-holder is secured and through which the vertical adjusting-screw passes, to travel across the carriage in transverse grooves in the latter. This is accomplished by a transverse screw, which rotates in an upright projection on one side of the sliding frame. The screw carries a pinion meshing with a cog-wheel attached to the sliding frame, and provided on its outer surface with internal gearing. Said wheel has a vibrating lever attached by one end to its projecting shaft, which carries a reversible detent to act on the internal gearing of the cog-wheel, and has attached to its lower end a depending arm, which, when the sliding frame is drawn backward on the main frame by means of a handle fixed to its rear upper surface for the purpose, strikes against an adjustable projection attached to the latter, and moves the rectangular piece, more or less, in the transverse grooves of the carriage. That part of the main frame provided with ways is adjustable on the other part, and the cleats

on the carriage are adjustable to the ways in which they slide by means hereinafter described.

In the drawing, A represents the main frame of the machine, composed of two parts—the one consisting of a base and a vertical portion, the other of a rectangular frame provided with longitudinal ways fitting over the upright part of the first part, and capable of being vertically adjusted upon it by means of the slots *aa* and clamp-screws *a'a'*. B is the carriage, moving longitudinally on the main frame, said main frame being provided with ways on its sides in which cleats fixed to the carriage fit. The cleats are made adjustable, by means of slots *b²* and clamp-screws *b³* on one side, to the grooves, in order to provide for the wear of the latter, and cause the tool always to run true. The handle by which the carriage is moved is attached to its rear upper surface. C is the rectangular piece, sliding in grooves *cc*, formed by attaching cleats *c'¹* to the upper surface of the carriage, and made adjustable laterally by the transverse screw D, which rotates in the upright projection *d* on one side of the carriage, and acts upon a similar projection on the rectangular piece C. The wear of the grooves *cc* is provided for by one of the cleats *c'¹* which form them, being provided with slots *c²* and clamp-screws *c³*, similar to the slots and screws at *b²* and *b³*, respectively. On the projecting outer end of the screw D is fixed the pinion E, which meshes with the wheel F. Said wheel is provided on its outer surface with the internal gearing *ff'*, which the V-shaped reversible detent G engages, the latter being pivoted to the vibrating lever H, which turns on the shaft of the wheel F, and carries the depending arm I, pivoted near the middle of the lever, and provided with a projection on its inner surface that fits loosely in a notch in the lower end of the lever H, and allows but slight lateral motion to the arm. The lower end of said arm is pointed, to allow it to slip more easily over the projection J, which is made adjustable on a forwardly-inclined arm fixed to the base of the main frame by means of the screws *j*. On the upper surface of the rectangular piece C is firmly fixed the hollow cylinder K, through a female screw in which

the screw L, for vertical adjustment of the tool-holder M, passes. The upper portion of said screw is of greater diameter and finer threaded than its lower portion, which engages the upper portion of the tool-holder M, and to its projecting upper end is fixed the cog-wheel N. The lever O imparts motion to said cog-wheel, and thence to the screw L, being secured over the former by a nut, and having attached to its under surface two projections, *o o'*, which carry the pawl P engaging the teeth of the wheel N. Said pawl has an arm, *p*, on its outer end, which fits into corresponding grooves *m* on each side of the outer projection *o*, and between said projections is surrounded by a spiral spring, *n*. The pawl is thus reversible by pulling the arm *p* from one of the grooves *m*, turning it half round, and allowing the spring *n* to draw it into the opposite groove. The spring also makes it engage the teeth of the wheel N. On the rectangular piece C is also fixed an adjustable gage, R, which regulates the distance the lever O travels. Said gage is composed of the standards S and bent arm T. The latter slides in a hole in the former, and its upright portion may be fixed at any distance from the standard by means of the clamp-screw *s*.

The machine being in position on a millstone, the ways and projections *b b'* may be adjusted parallel to its face by means of the slots and screws *a a*. The tool is then lowered to the surface of the stone by turning the lever O, the adjustable gage R regulating the number of teeth of the wheel N. The pawl P passes when it is necessary to cut grooves with inclined bottoms. The pawl may press only one tooth each time the carriage travels

back and forth over the main frame. When it is necessary to raise the tool, the pawl is reversed, when the same motion of the lever that before depressed it now raises it. The tool being set, the carriage B is drawn by its handle to the rear of the main frame, where the arm I, striking the projection J, will, by means of the lever H and detent G, rotate forward the wheel F, which will, by means of the pinion E and screw D, impart its motion to the rectangular piece C. The wheel F may be more or less rotated by adjusting the projection J higher or lower on the inclined arm fixed to the base of the frame. The detent G will not engage when the arm I passes back over the projection J. When it is necessary to reverse the motion of the rectangular piece, the detent G is reversed, which is done by turning it over on its pivot.

Having thus described my invention, what I claim as new is—

1. In a diamond-tool millstone-dressing machine, the combination, with a longitudinally-grooved main frame, A, of a carriage, B, cleats *b¹* and *c¹*, provided with the slots *b²* and *c²* and clamp-screws *b³* and *c³*, substantially as shown and described, for the purpose specified.

2. In a diamond-tool millstone-dressing machine, the combination of the main frame A and carriage B, tool-holder M, vertical screw L, cog-wheel N, lever O, reversible spring-pawl P, and adjustable gage R, substantially as shown and described, for the purpose specified.

AARON C. PRY.

Witnesses:

C. W. HICKMAN,
O. J. BAKER.