

J. Du BOIS.  
MATCH-MACHINE.

No. 182,750.

Patented Oct. 3, 1876.

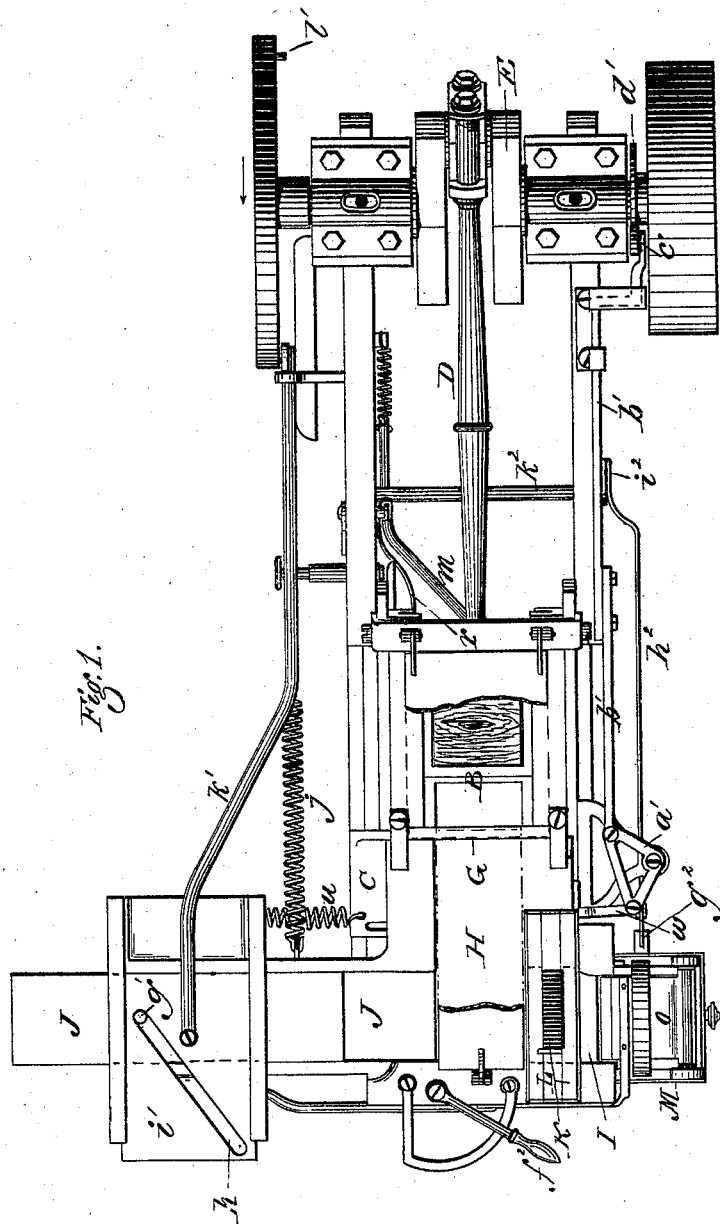

Witnesses:  
 Will H. Dodge.  
 Wm. S. Switcheil.

Inventor:  
 John Du Bois  
 By his attys.  
 Dodge & Son

J. Du BOIS.  
MATCH-MACHINE.

No. 182,750.

Patented Oct. 3, 1876.

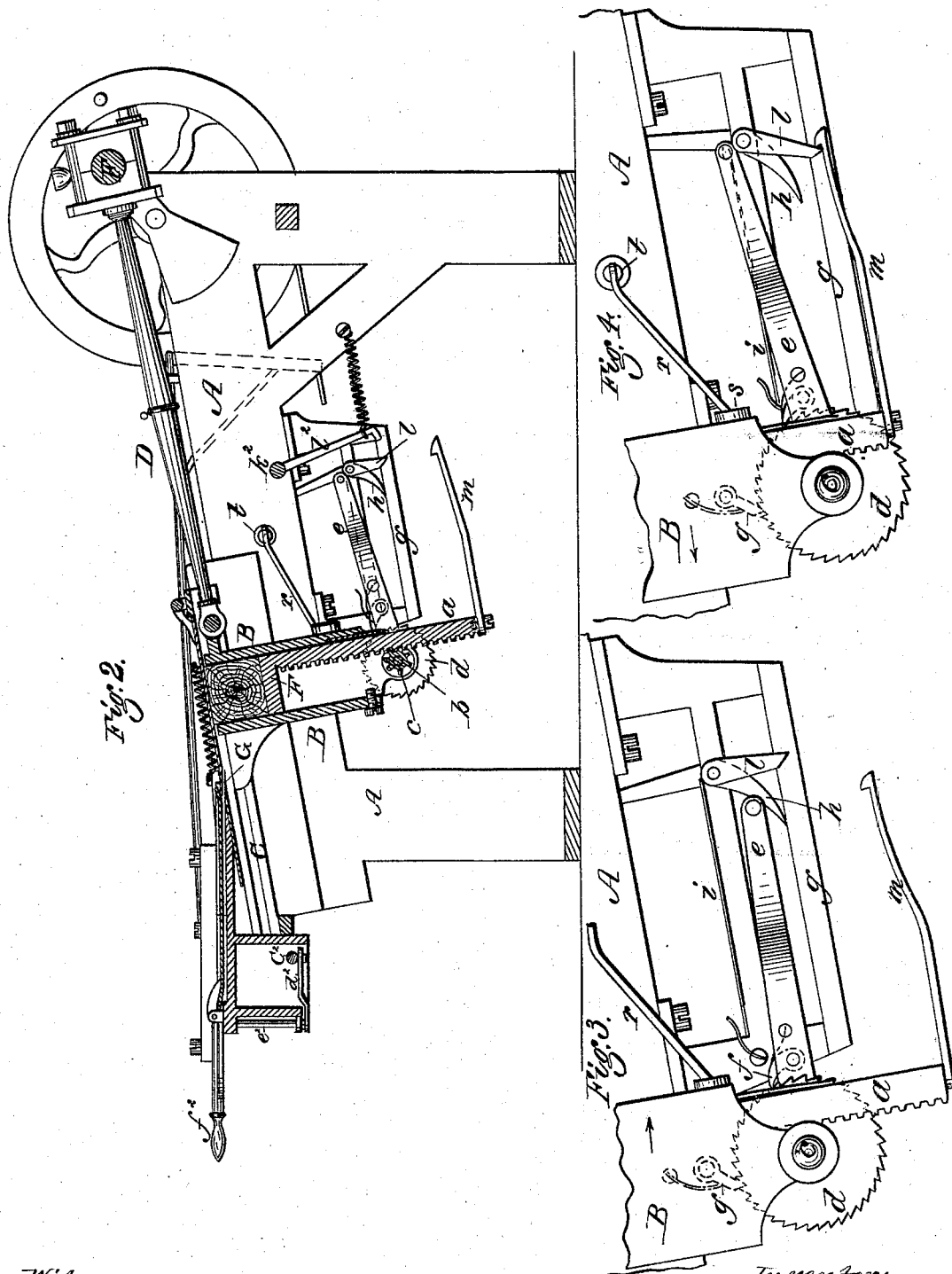

Witnesses:  
 Will H. Dodge.  
 Dorn S. Fitchell.

Inventor:  
 John Du Bois.  
 By his Atty's  
 Dodge & Son.

J. Du BOIS.  
MATCH-MACHINE.

No. 182,750.

Patented Oct. 3, 1876.

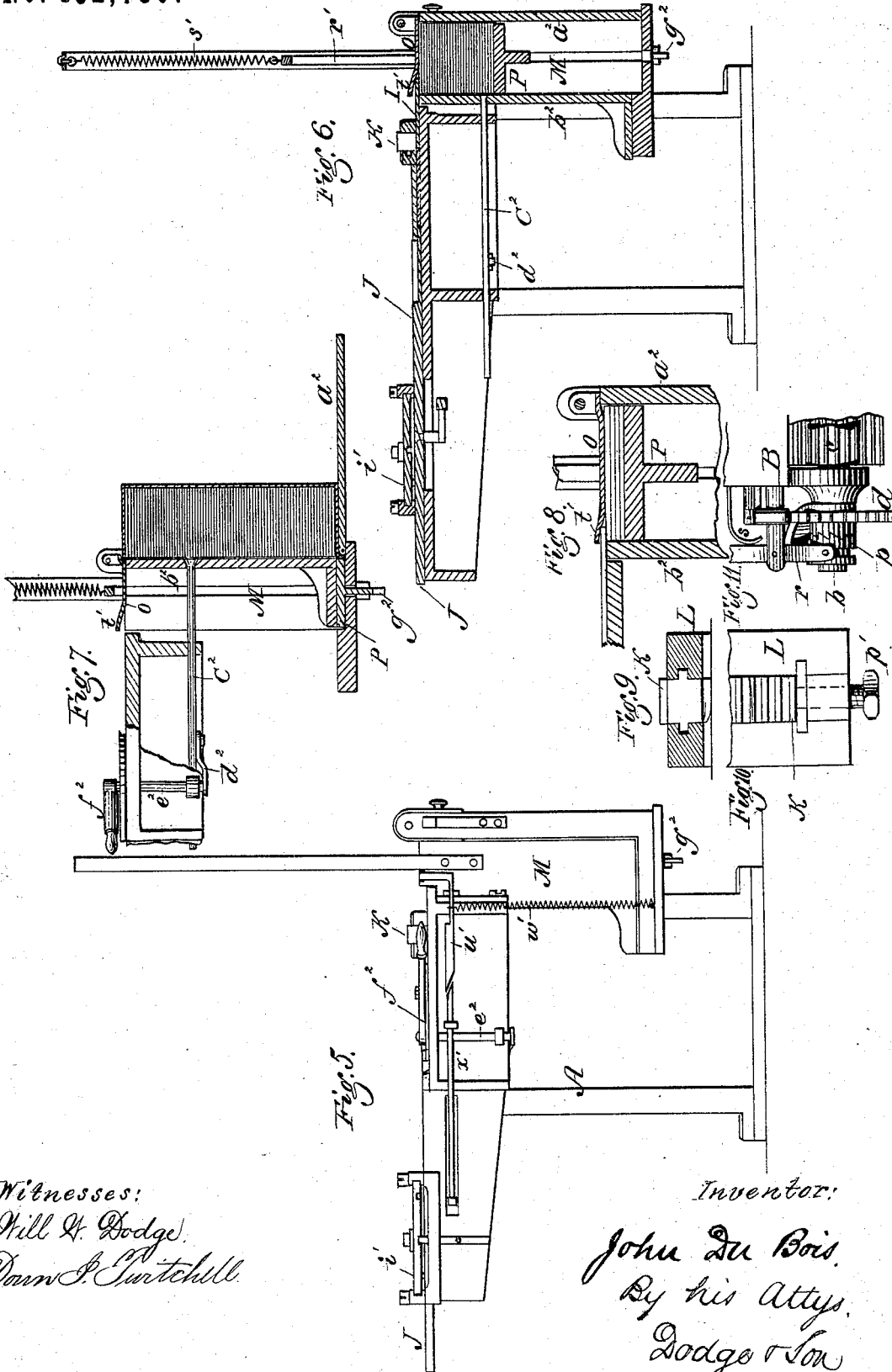

Witnesses:  
 Hill H. Dodge.  
 Dan S. Twitchell.

Inventor:  
 John Du Bois.  
 By his Atty.  
 Dodge & Son

# UNITED STATES PATENT OFFICE.

JOHN DU BOIS, OF WILLIAMSPORT, PENNSYLVANIA.

## IMPROVEMENT IN MATCH-MACHINES.

Specification forming part of Letters Patent No. 182,750, dated October 3, 1876; application filed June 29, 1876.

*To all whom it may concern:*

Be it known that I, JOHN DU BOIS, of Williamsport, in the county of Lycoming and State of Pennsylvania, have invented certain Improvements in Match-Machines, of which the following is a specification:

My invention relates to an automatic machine for cutting and packing match-splints; and consists in certain novel combinations of mechanism, whereby the wooden block or bolt is carried against a knife, and divided in line with the grain into slices, the slices carried between splitting-knives and divided into splints, and the splints packed closely into a receiving-chamber, and delivered thence into a box or receptacle of any suitable character, as hereinafter fully described and explained.

The machine consists essentially of three main combinations: First, that for feeding and slicing the blocks; second, that for dividing the slices into splints; and, third, that for packing and delivering the splints.

The combination for feeding and slicing the blocks consists of a horizontal knife having a slight movement endwise, in order that it may cut cleanly, and of a reciprocating box to contain the wooden block sliding closely under the knife, and provided with a movable bottom, which is raised at each reciprocation, so as to lift the block in order that the knife may cut the successive slices therefrom.

The combination for splitting the slices into splints or sticks consists of a series of stationary knives, mounted in a throat or passage, and of a reciprocating slide or plunger, which forces the slices through the throat between the knives.

The combination for packing the splints consists of a chamber provided with a hinged rising cover, and with a yielding bottom, urged upward by a spring, the splints being forced inward under the edge of the cover, and held snugly and compactly by the bottom, which is gradually forced down as the chamber is filled from above. The chamber is provided with a hinged delivery-door, and with a sliding back, which can be pushed forward to deliver the splints through the front into a box or other receptacle.

The above combinations, their organization for joint operation in one machine, and vari-

ous minor features, hereinafter described, constitute my invention.

Figure 1 represents a top plan view of my machine; Fig. 2, a longitudinal central section of the same. Figs. 3 and 4, enlarged side views of the mechanism for feeding the block upward, and of the safety devices for throwing the same out of action; Fig. 5, a rear end elevation of the machine; Fig. 6, a transverse vertical section of the machine on the line *yy* of Fig. 1; Fig. 7, a section through the receiving-chamber on the line *yy*, showing the manner in which the splints are delivered from the machine; Fig. 8, an enlarged sectional view through the top of the receiving-chamber, showing its hinged top, and the manner in which the splints are introduced thereunder; Figs. 9 and 10, respectively, a cross-section and a top plan, showing the form and arrangement of the splitting-knives; Fig. 11, a view showing the arrangement of the devices for permitting the descent of the carriage-bottom.

A represents the frame of the machine; and B a reciprocating box-like carriage, mounted in ways C, in one end of the frame, and operated by a pitman, D, connecting with a transverse crank-shaft, E, mounted in the opposite end of the frame, as shown. The carriage B is intended to receive and carry the wooden block or bolt from which the splints are to be cut, and is provided with a vertically-sliding bottom, F, which is gradually elevated as the operation of the machine progresses, in order to raise the top of the block above the carriage. G represents the main knife, arranged horizontally across the frame in such position that it cuts a slice from the top of the block at each advance of the carriage, the carriage and the body of the block passing under the knife while the slice taken off passes over the same.

The arrangement for elevating the carriage-bottom F is clearly shown in Figs. 2, 3, and 4, in which it will be seen that the bottom is provided with a depending rack-bar, *a*, acted upon by a pinion, *b*, mounted on a transverse shaft, *c*, having its bearings in the sides of the carriage. The end of the pinion-shaft *c* is provided with a ratchet-wheel, *d*, and a vibrating lever, *e*, the latter provided with a pawl, *f*, en-

gaging in the wheel, as shown, so that the operation of the lever will serve to transmit motion to the rack-bar, and thereby raise the bottom F. The descent of the bottom during the backward movement of the lever is prevented by a pawl, *g*, mounted on the side of the carriage, and engaging in the ratchet-wheel, as shown.

The vibration of the lever *e* is effected, as shown in Figs. 2, 3, and 4, by means of a horizontal guide, *g'*, an inclined pivoted dog, *h*, resting at its lower end on the guide, and a straight spring, *i*, arranged above and parallel with the guide, and bearing at its end on the upper end of the dog. As the lever is carried backward with the carriage in its movement, a stud on the side of the lever rides upon the guide *g'* and up the inclined dog under the end of the spring *i*, thereby raising the lever and elevating the carriage-bottom, and then, as the carriage moves forward, the stud rides back on top of the spring to its end, when it rides off and allows the lever to fall.

In this way, it will be seen, the lever is raised and the carriage-bottom elevated with a positive motion at each backward movement of the carriage, so that at each forward movement the wooden block or bolt will project above the carriage a distance equal to the thickness of the slice to be taken off by the knife.

For the purpose of automatically throwing the mechanism which elevates the carriage-bottom F out of action when the block of wood is reduced to the thickness of one slice or splint, the lever-elevating dog *h* is provided with an arm, *l*, and the rack-bar of the movable bottom provided at its lower end with a rigid hooked arm, *m*, as shown in Figs. 2, 3, and 4. When the bottom reaches the fixed limit of elevation, the arm *m* engages over the arm *l*, and, as the carriage moves forward, causes the same to turn the dog *h* up out of action, as shown in Fig. 4, so that it will no longer operate the lever.

In this way the rise of the bottom F is checked with absolute certainty whenever the block of wood thereon is reduced to the proper thinness, and all danger of the bottom being brought in contact with the knife avoided.

In order that the bottom F may be readily released and lowered, to permit the introduction of a new block or bolt of wood into the carriage, the ratchet-wheel *d* is mounted, as shown in Fig. 11, loosely on the pinion-shaft *e*, and arranged to drive the same by means of a sliding clutch, *p*, mounted on a spline on the shaft and engaging in teeth on the side of the wheel, so that, by shifting the clutch side-wise, the pinion-shaft may be released, and the bottom F thereby permitted to descend. The clutch *p* is connected, as shown, with a shifting-lever, *r*, pivoted to the side of the carriage, and acted upon by a spring, *s*, which tends to keep the clutch engaged with the ratchet-wheel.

As shown in Figs. 1, 2, and 4, a sliding pin,

*t*, is passed through the side of the main frame in such position that when the carriage B is moved back in the machine, the end of the pin stands opposite the lever, as shown in Fig. 4, so that, by simply pressing the pin inward, the lever and clutch will be operated, and the bottom F permitted to fall.

The main knife or cutter G consists simply of a thin flat blade with a straight cutting-edge, arranged, as before mentioned, horizontally across the machine, in order to slice the wood from the top of the block in the carriage B. In order that the knife may be certain to make a smooth clean cut, and that it shall not leave the rear edge of the wood rough and ragged, it is arranged to have a sliding movement endwise in a straight line, so that it acts with a draw cut. This movement of the knife is effected, as shown in Fig. 1, by attaching a spiral spring, *w*, to one end, and connecting the opposite end by a link, *w*, to an elbow-lever, *a*<sup>1</sup>, which is mounted on the main frame, and pivoted to a sliding rod, *b*<sup>1</sup>, which latter has its opposite end provided with a roller, *c*<sup>1</sup>, acted upon by an eccentric, *d*<sup>1</sup>, on the main shaft.

While acting upon the wood the knife is moved in one direction by the eccentric, and then, as the carriage retreats with the wood, the knife is drawn back by the spring to its original position.

In operating the machine the wood is placed in the carriage with its fiber lying across the machine, parallel with the edge of the knife, so that the latter cuts into the side of the grain parallel therewith. In this way I am enabled to secure a smooth and perfect slice at each cut, regardless of the crookedness or obliquity of the grain, a result which it is impossible to secure by a knife entering the end of the grain and splitting the slice from the block, for the reason that in the latter case the split will always follow the grain.

My method of cutting enables me to make straight and perfect splints without waste from wood which it is impossible to utilize in machines operating in the usual manner.

The slices of wood removed by the knife G pass over the same, one after another, into a horizontal passage or channel, H, of corresponding size, as shown in Figs. 1, 2, and 6. From the side of and at right angles to the passage H there extends a second passage or throat, I, into which the slices are pushed from the passage H by the end of a horizontal slide, J, arranged as shown in Figs. 1 and 6. The movement of the slide J is produced by means of a stud, *g*<sup>1</sup>, thereon, working in an oblique slot, *h*<sup>1</sup>, in a transversely-sliding plate, *i*<sup>1</sup>, which latter is drawn first in one direction by a spiral spring, *j*<sup>1</sup>, and then in the opposite direction by a rod, *k*<sup>1</sup>, which latter has its rear end bent downward, so as to be caught and moved by a stud, *l*<sup>1</sup>, on the side of a wheel, *m*<sup>1</sup>, mounted on the main shaft of the machine, as shown in Figs. 1 and 2. The stud *l*<sup>1</sup>, catching the end of the rod *k*<sup>1</sup>, draws the sliding

plate  $j'$  backward, thereby advancing the slide J, and causing it to force the slice of wood out of the passage H, and then, as the stud rides from the end of the rod, the parts are instantly restored to their original positions by the action of the spring  $j'$ . The forward movement of the slide J to eject the slices from the passage H, and its retreat, both occur during the backward movement of the carriage, so that it is out of the way of the next incoming slice, which is forced forward directly in front of the slide. In the passage or throat I there is mounted a series of vertical parallel knives, K, which divide the slices of wood, as they are driven forward by the slide J, into splints or sticks of the required size. The form and arrangement of these knives are clearly represented in Figs. 1, 5, 6, 9, and 10. As shown in Fig. 9, the cutting-edges are inclined or rounded upward toward the front, so that they cut obliquely across the grain, whereby they are caused to separate the splints cleanly and accurately. The knives are mounted, as shown in Figs. 9 and 10, in a bridge-bar, L, and separated from each other by thin metal plates  $o'$ , which are sustained by ears bearing in grooves in the bar. The knives are simply dropped between the previously-inserted plates, and then the series of knives and plates crowded firmly together by means of a bolt,  $b''$ , mounted in the end of the bridge-bar, as shown in Fig. 10. By loosening the bolt the knives are released, so that either or all of them may be lifted out.

For the purpose of receiving and holding the splints or sticks as they are delivered from the splitting-knives K, there is arranged directly behind said knives, opposite the end of the passage I, as shown in Figs. 1, 2, and 6, a vertical chamber, M, having a hinged top, O, and a vertically-sliding bottom, P, as shown in Figs. 6 and 7. As shown in Figs. 6 and 7, the bottom P is provided with arms  $r$ , connected to a sustaining-spring,  $s'$ , which tends constantly to draw the bottom upward. The hinged top O is arranged with its free edge toward splitting-knives, and has said edge slightly raised or bent upward, as shown at  $t'$ , Figs. 7 and 8. On one side the top is provided, as shown in Figs. 1 and 5, with an arm,  $u'$ , to which there is attached a spring,  $w'$ , to hold the top down. An arm,  $x'$ , is, however, attached to the reciprocating slide J, as shown in Figs. 1 and 5, so that each time the slide moves forward to carry the wood to the splitting-knives the arm  $x'$  rides under the arm  $u'$ , and thereby lifts the edge of the top O sufficiently to permit the splints to be crowded thereunder into the chamber M, as shown in Fig. 8. As the slide J moves back the cover is depressed by the spring  $w'$ , and the splints forced down into the chamber, so that at the next movement of the slide and cover another layer of splints will be forced in on top of those previously delivered. Each slice, when divided, forms one layer of splints in

the chamber, so that, by the successive movements of the slide, one layer after another is delivered smoothly and evenly into the chamber, the bottom of which is gradually forced downward until the chamber is filled.

In order that the splints may be readily delivered from the chamber M, its front side  $a^2$  is hinged to swing outward like a door, its edges recessed to receive the edges of a box or receptacle S, and, its back  $b^2$  arranged so that it may be pushed forward through the chamber, in order to force the splints therefrom into the box, as clearly represented in Fig. 7. The sliding back  $b^2$  is attached to and moved by a sliding rod,  $c^2$ , which is moved by an arm,  $d^2$ , on the lower end of a vertical rock-shaft,  $e^2$ , which is provided at its upper end with a hand-lever,  $f^2$ , as shown in Figs. 1, 2, 6, and 7, so that, after the door of the chamber M is opened, and the box or receptacle placed in position, the movement of the lever  $f^2$  serves to deliver the body of splints smoothly and compactly into the box. In order to stop the production of the splints automatically when the chamber M becomes filled, the bottom P is arranged, as shown in Figs. 5 and 6, to act against one end of an elbow-lever,  $g^2$ , which latter is connected, as shown in Fig. 1, by a rod,  $h^2$ , to an arm,  $i^2$ , on one end of a rock-shaft,  $k^2$ , which has its opposite end provided with a depending arm,  $l^2$ , which latter is arranged to act against the arm of the lever-operating dog. When the bottom P, reaching the bottom of the chamber, acts upon the elbow-lever  $g^2$  motion is communicated, through the intermediate devices, to the arm  $l^2$ , which is caused to throw the dog up out of action, thereby stopping the action of the feeding mechanism so that the wood will be no longer fed to the knife.

In operating the machine, it is desirable that the block of wood shall not rub against the under side of the knife when moving backward, for which reason the pawl-lever is given a movement of such length that at each stroke it turns the ratchet-wheel  $d$  slightly beyond the point at which it will be held by the pawl  $g$ , so that, while the block is being carried forward against the knife, it is sustained by the lever, the end of which slides forward upon the spring  $i$ , but at the end of the forward movement the end of the lever falls, and the ratchet-wheel  $d$  is permitted to turn slightly backward before being caught by the pawl  $g$ , the effect of which is to lower the block away from the knife as it is carried backward.

By presenting the blocks of wood to the slicing-knife in the manner described, with the grain parallel to the edge of the knife, two important advantages are gained in addition to those already mentioned: first, the machine is adapted for cutting the wood when green and wet, directly as it comes from the log, without being seasoned; and, second, that it does not bend or weaken the sticks crosswise of the grain, as is the case with those

machines in which the knife enters the end of the wood, for the reason that when slices are cut from a block by a knife the slices must spring or bend sufficiently to allow the blade to pass between them and the block, and that the thinnest blade which can be used bends the wood crosswise of the grain to a very injurious extent, while on the other hand the wood presented sidewise will readily bend as it is sliced off without being weakened or injured thereby.

Having thus described my invention, what I claim is—

1. The combination of the knife G and the reciprocating carriage B, provided with the vertically-movable bottom F with mechanism, substantially such as shown and described, for operating the same.

2. The combination of the series of parallel stationary splitting-knives K, mounted in the throat or passage I, and the reciprocating slide J, arranged to operate as described.

3. In combination with the slide J and splitting-knives K, the receiving-chamber M, provided with the hinged cover O and movable bottom P, arranged to operate substantially as shown and described.

4. The match-machine, consisting of the slicing devices B G, the passages H I, the slide J, the splitting-knives K, and the receiving-chamber M, all combined and arranged to operate substantially as shown and described.

5. In combination with the reciprocating carriage B, for holding the wood and presenting the same to the knife, the knife G, arranged to move endwise during the advance of the carriage, substantially as shown and described.

6. The combination of the reciprocating carriage B, provided with the sliding bottom F, having the rack-bar *a*, the shaft *c*, provided with the pinion *b* and ratchet-wheel *d*, and the vibrating lever *e*, provided with the pawl *f*, with devices, substantially such as shown and described, for imparting the vibration to the lever at each movement of the carriage.

7. In combination with the vibratory lever

*e*, mounted upon the reciprocating carriage B, as and for the purpose described, the guide *g*<sup>1</sup>, dog *h*, and spring *i*, mounted on the main frame.

8. In combination with the pinion-shaft *c* and ratchet-wheel *d*, communicating with the movable carriage bottom, as shown, the clutch *p*, and lever *r*, for permitting the descent of the bottom.

9. In combination with the dog *h*, provided with the arm *l*, and arranged to operate as described, the hooked arm *m*, connected with the carriage-bottom F, as and for the purpose described.

10. In combination with the dog *h*, provided with the arm *l*, the shaft *k*<sup>2</sup>, provided with the arms *l*<sup>2</sup> and *i*<sup>2</sup>, the rod *h*<sup>2</sup>, lever *g*<sup>2</sup>, and the sliding bottom P, of the receiving-chamber M, arranged to operate said lever, for the purpose of stopping the production of splints when the chamber becomes filled, as described and shown.

11. The receiving-chamber M, provided with the hinged front *a*<sup>2</sup>, and with the sliding back *b*<sup>2</sup>, for expelling the splints or sticks from the chamber.

12. In combination with the ratchet-wheel *d*, arranged to elevate the carriage-bottom F, as described, the pawl *g* and the lever *e*, provided with the pawl *f*, and arranged to turn the wheel at each movement beyond the point at which it will be held by the pawl *g*, as described, so that the wooden block may fall away from the knife during its backward movement.

13. The combination, substantially as shown and described, of a knife, G, a reciprocating carriage, B, adapted to present a block of wood to the knife, and devices, substantially such as shown, arranged to raise the block prior to each forward movement, so that the knife can cut a slice therefrom, and then lower the block away from the knife during the backward movement, to avoid friction.

JOHN DU BOIS.

Witnesses:

GEO. R. VASBURG,  
DAVID DU BOIS.