

T. H. HUTCHINSON.
WATER-ELEVATOR.

No. 182,759.

Patented Oct. 3, 1876.

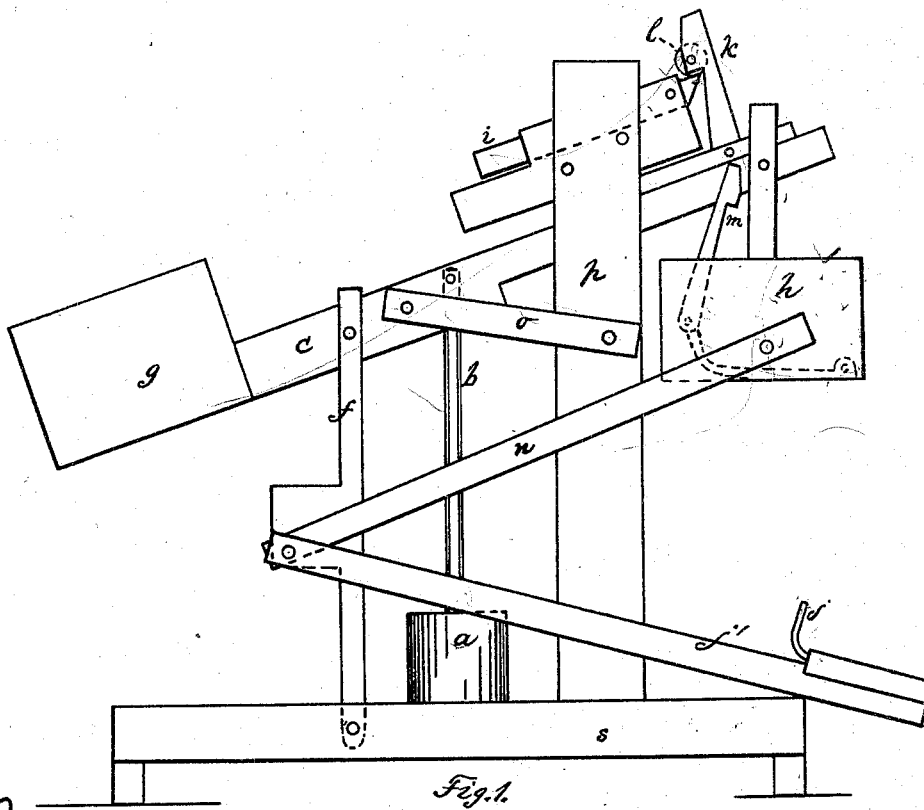

Fig. 1.

In witness whereof,
I, Timothy H. Hutchinson,
have hereunto set my hand
and seal, this 1st day of
September, 1876.

Inventor:
Timothy H. Hutchinson
per Eugene O. Stiles
att'y.

UNITED STATES PATENT OFFICE.

TIMOTHY H. HUTCHINSON, OF GORHAM, NEW HAMPSHIRE.

IMPROVEMENT IN WATER-ELEVATORS.

Specification forming part of Letters Patent No. **182,759**, dated October 3, 1876; application filed June 3, 1875.

To all whom it may concern:

Be it known that I, TIMOTHY H. HUTCHINSON, of Gorham, in the county of Coos and State of New Hampshire, have invented certain new and useful Improvements in Water-Elevators; and I do hereby declare that the following is a full, clear, and exact description thereof, which will enable others skilled in the art to which it pertains to make and use the same, reference being had to the accompanying drawings, and to the letters of reference marked thereon, which form a part of this specification.

Figure 1 is a side elevation.

Same letters show like parts.

The object of my invention is to produce certain improvements in automatic-working water-elevators. It consists in an arrangement of parts by which a natural falling body of water may be made to raise a portion to a desired point or elevation, as herein described.

My invention may be thus described: *a* shows the pump for forcing the water. *b* is the piston, which is operated by the upward and downward movement of the lever *c*, to which it is pivoted, as shown. This lever is pivoted to a rocking stanchion, *f*, and has on one end the weighted box *g*, and on the other the water-reservoir *h*.

The object of having the lever *c* pivoted to a rocking stanchion is that, in its upward and downward movement, it will accommodate itself to the movement of the piston, and not allow the said piston to move in any but a true vertical direction.

Near the water-receptacle is the weighted block *i*, pivoted in such a manner as to hold the water-reservoir in position when being filled with water, and when it is filled this weighted block yields to the superior pressure, and the said reservoir carries its end of the lever *c* down with it to the tank from which the pump is fed. When it arrives at the lowest point in its descent it strikes upon the upright pin *j*, on the pivoted frame *j'*, which pin opens a valve, through which the water is discharged into the water-tank from which the pump is fed.

On the top of the end of the lever to which the reservoir is attached is pivoted the latch *k*, provided with the small wheel *l*, which

catches upon the end of the weighted block *i*, and holds the said reservoir in position until the water in it overcomes the weight of the block, when it is released and descends to the supply-tank.

The purpose of the pivoted frame *j'* is that, should there be any back or waste water higher than that in the tank from which the pump is fed, it will rest or float upon it, and cause the pin to be held in such position that it will discharge the contents of the reservoir each time it descends.

m is a lever, provided with a notch, and is fastened to the valve in the water-reservoir. Its purpose is that, when the valve is raised by contact with the pin *j* as it (the reservoir) descends, it will raise this lever, and the notch will pass over a stud or equivalent projection, and hold the valve open until the weighted box on the opposite end of the lever *c* raises the reservoir to a point nearly high enough for the latch to catch the weighted block before described, when it falls off and allows the valve to close.

n is a lever attached to the pivoted stanchion *f*, before described, on one end, and to the lower side of the water-reservoir at the other end. The object of this is to insure the reservoir being held in a true vertical position during its descent and rise. *o* is an arm reaching from the lever *c* to the fixed stanchion *p*, and is pivoted at each end to these parts, and aids in producing the vertical movement of the piston *b* as the lever *c* moves up and down.

The supply of water can be furnished in any quantity, and can be brought from any distance to any desirable point. The elevator will work under any head of water, will stop only when all flow ceases, and will start automatically with the beginning of the smallest flow, and will continue to work so long as the materials of which it is made last.

It will be observed by reference to the drawing that the pivotal point of the arm *o* to the lever *c* is forward of the pivotal point of the piston—that is to say, that it is on the side of the weighted box. *s* shows the supply-tank.

What I claim as my invention, and desire to secure by Letters Patent, is—

1. The combination of the lever *c*, arm *o*,

rocking stanchion *f*, and piston *b*, with a pump, *a*, all arranged substantially as and for the purposes herein set forth.

2. The combination of the lever *c*, arm *o*, rocking stanchion *f*, lever *n*, and reservoir *h*, as and for the purposes set forth.

3. The combination, with the lever *c*, stanchion *f*, piston *b*, arm *o*, lever *n*, reservoir *h*, and pivoted frame *j'*, as and for the purposes set forth.

4. The combination, with the reservoir *h* and its valve, of the notched lever *m* and lever *c*, as and for the purposes set forth.

In testimony that I claim the foregoing as my own I affix my signature in presence of two witnesses.

TIMOTHY H. HUTCHINSON.

Witnesses:

FRANK H. JORDAN,
CHARLES E. CLIFFORD.