

J. E. WEAVER.

APPARATUS FOR EVAPORATING LIQUIDS.

No. 182,780.

Patented Oct. 3, 1876.

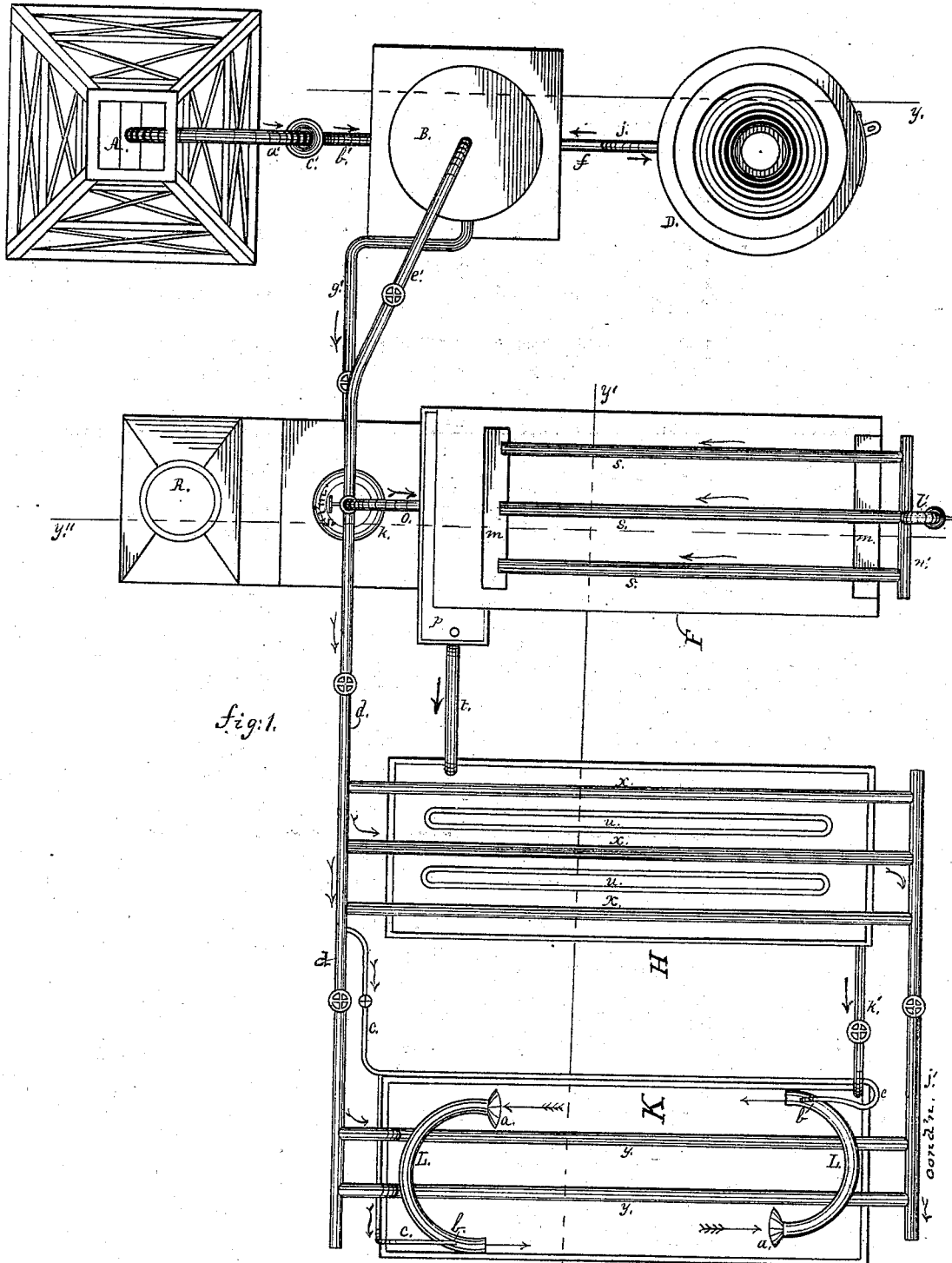

Fig. 1.

Witnesses
A. H. Johnston
Wesley Johnston

Inventor:
James E. Weaver
 By *Johnston & Dorris*
 his Attorneys

J. E. WEAVER.

APPARATUS FOR EVAPORATING LIQUIDS.

No. 182,780.

Patented Oct. 3, 1876.

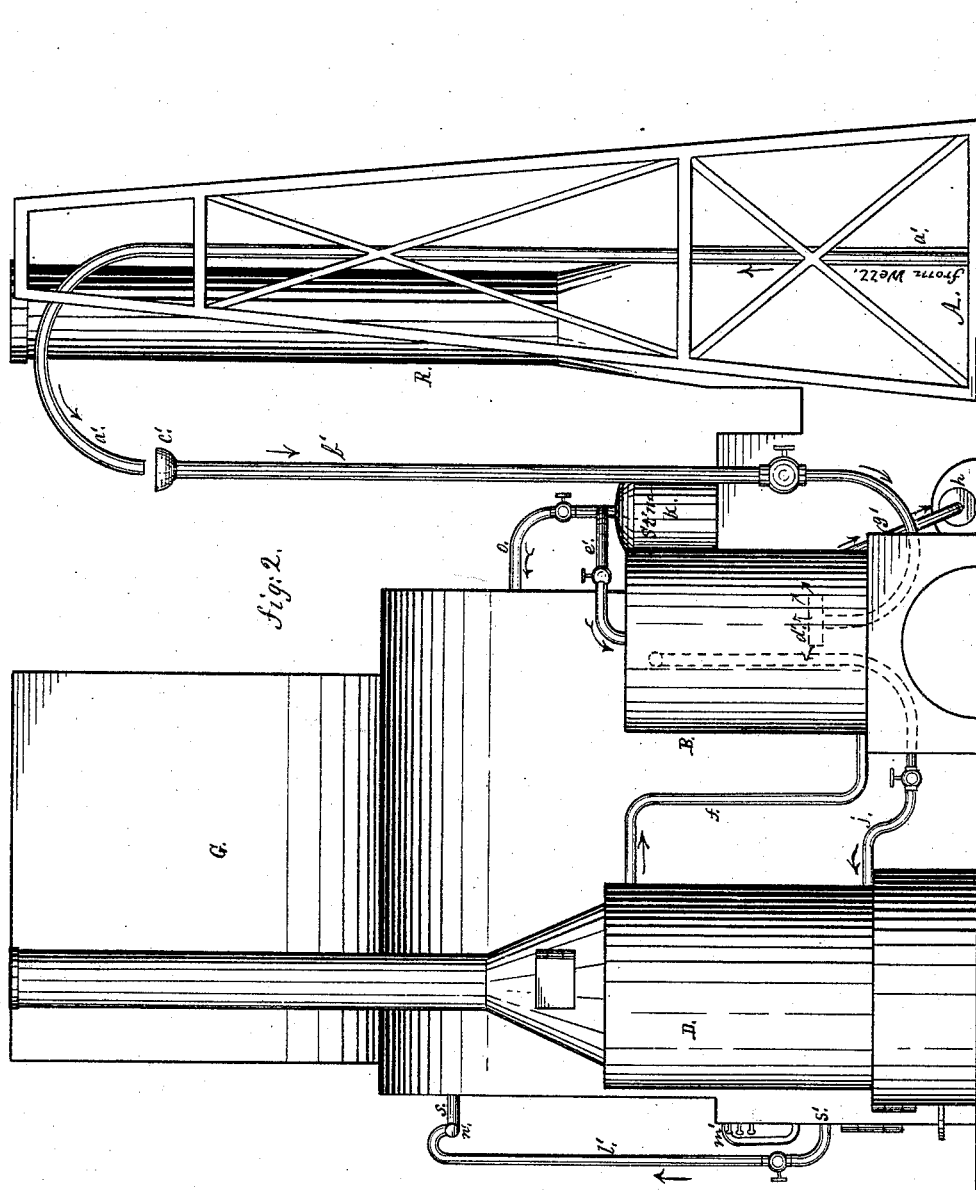

Fig. 2.

Witnesses.
James I. Johnston
W. Johnston

Inventor
J. E. Weaver

J. E. WEAVER.

APPARATUS FOR EVAPORATING LIQUIDS.

No. 182,780.

Patented Oct. 3, 1876.

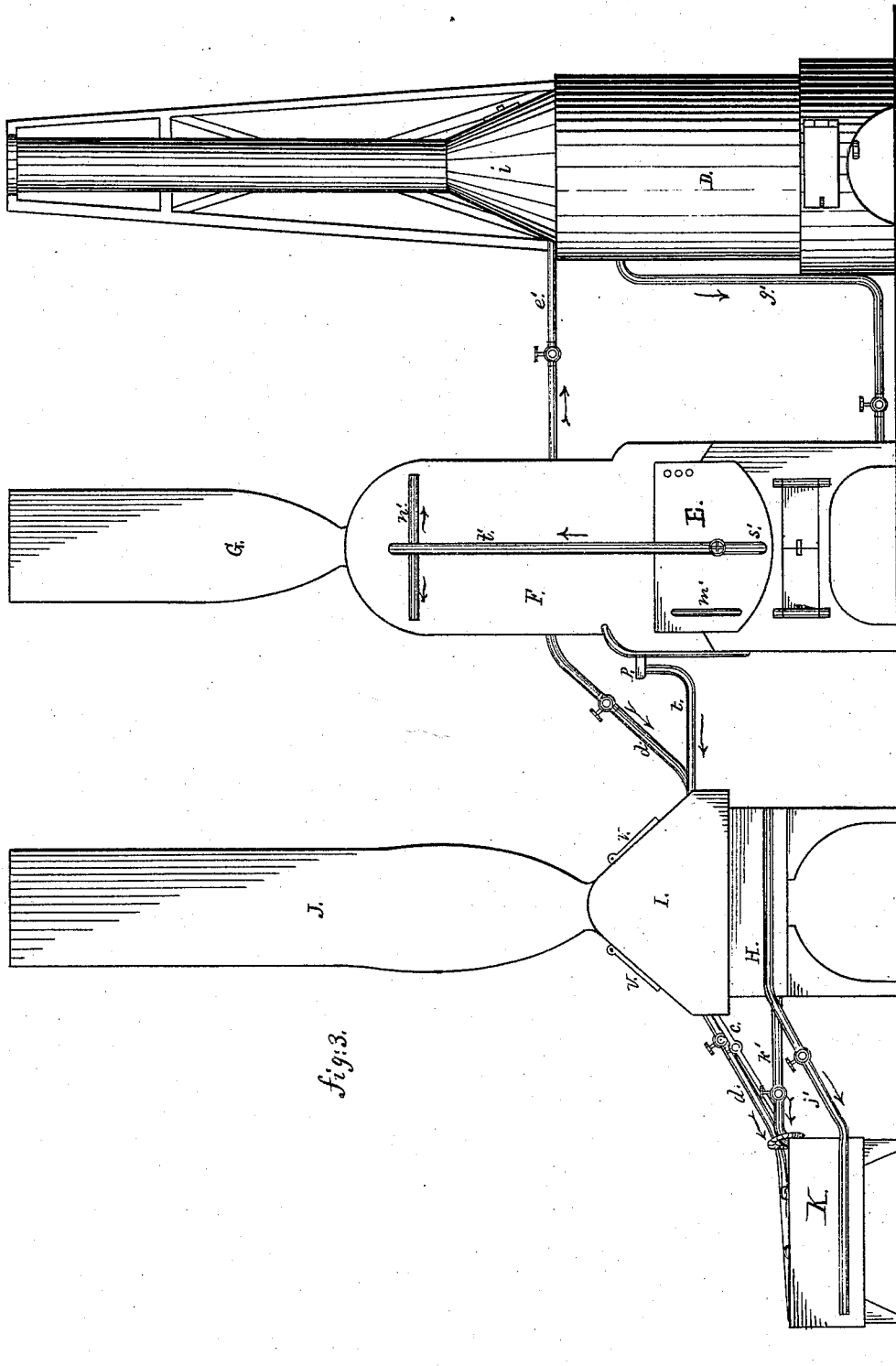

fig. 3.

Attest:
James Johnston
W. Johnston

Inventor:
J. E. Weaver

J. E. WEAVER.

APPARATUS FOR EVAPORATING LIQUIDS.

No. 182,780.

Patented Oct. 3, 1876.

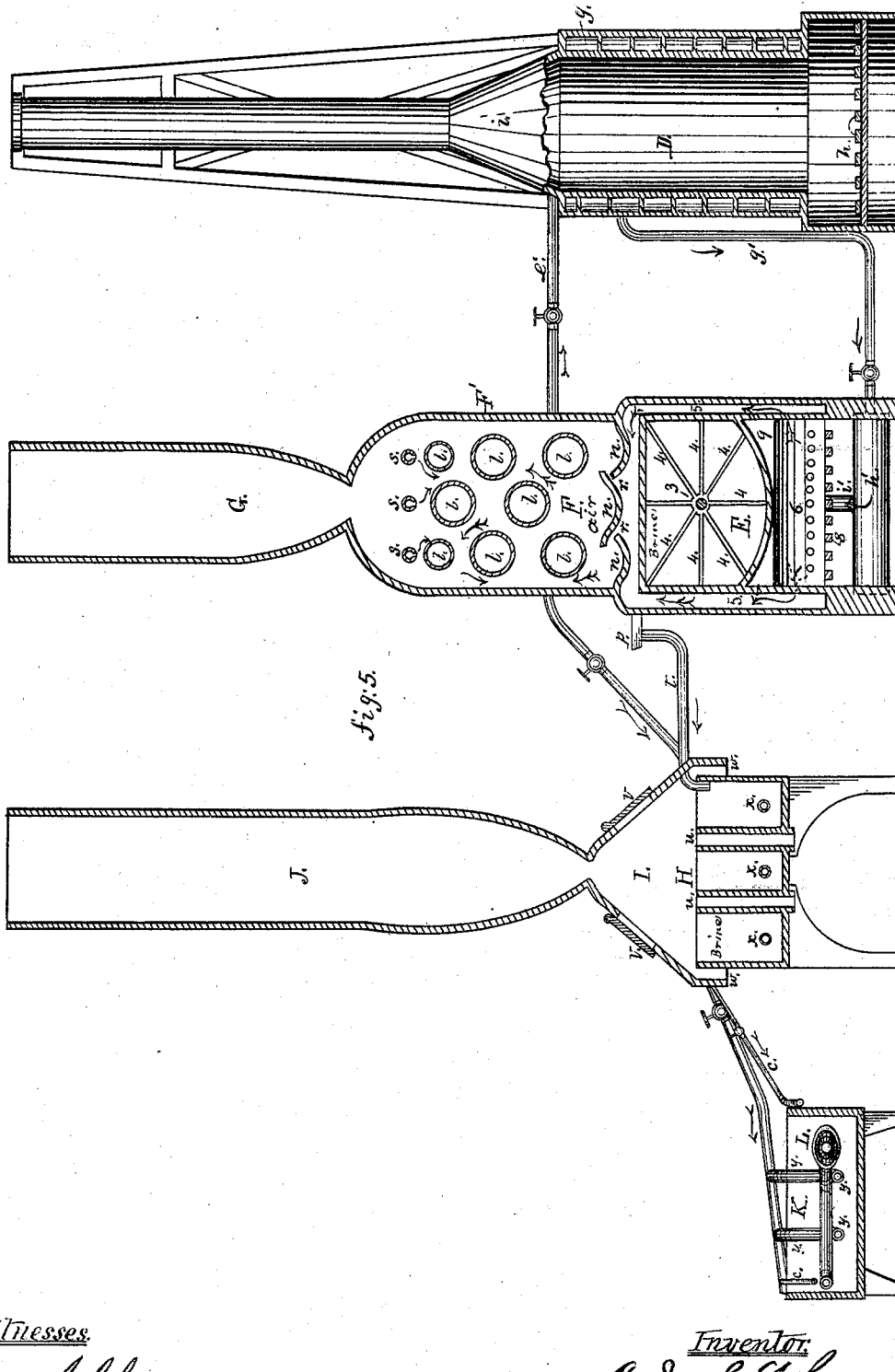
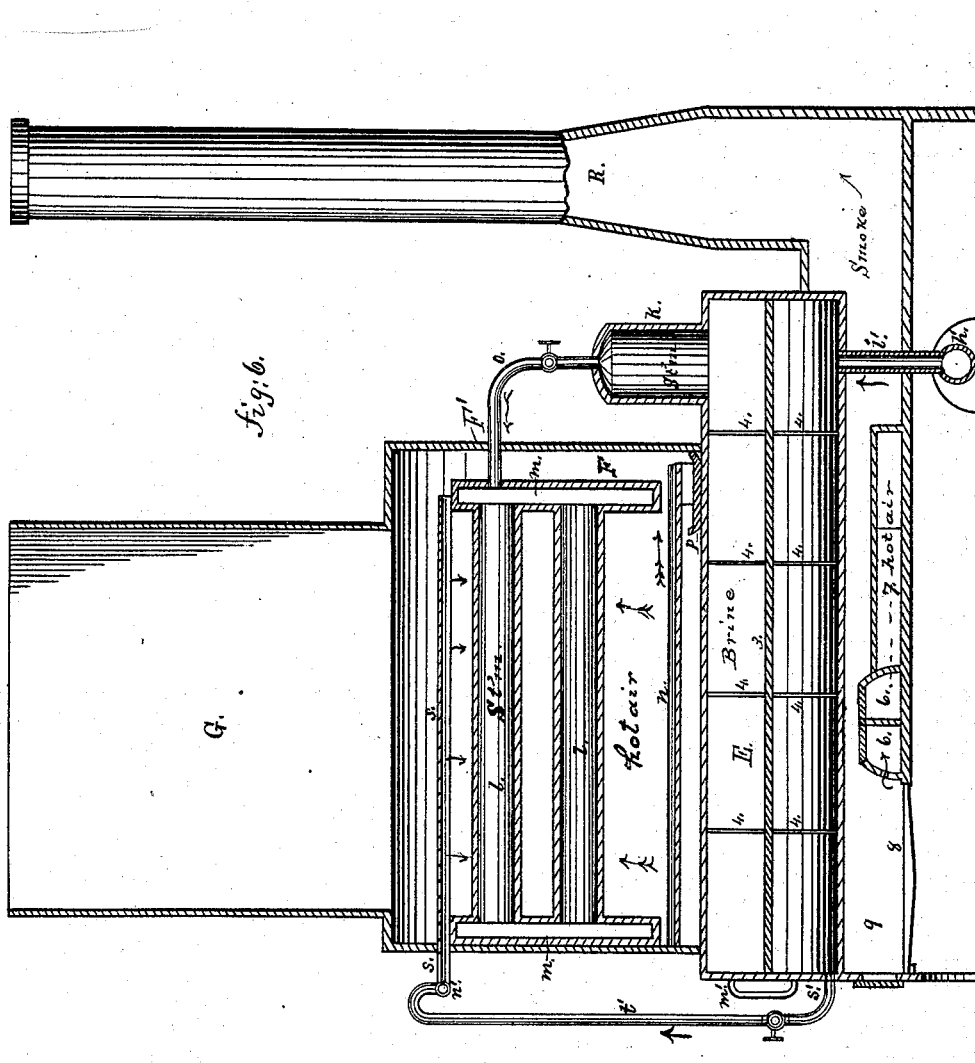

fig. 5.

Witnesses.
 James Johnston
 W. Johnston

Inventor.
 J. E. Weaver

J. E. WEAVER.
APPARATUS FOR EVAPORATING LIQUIDS.
No. 182,780. Patented Oct. 3, 1876.



Witnesses.
James I. Johnston
W. Johnston

Inventor.
J. E. Weaver

UNITED STATES PATENT OFFICE.

JAMES E. WEAVER, OF PITTSBURG, PENNSYLVANIA.

IMPROVEMENT IN APPARATUS FOR EVAPORATING LIQUIDS.

Specification forming part of Letters Patent No. 182,780, dated October 3, 1876; application filed January 24, 1876.

To all whom it may concern:

Be it known that I, JAMES E. WEAVER, of Pittsburg, in the county of Allegheny and State of Pennsylvania, have invented a new and useful Improvement in Apparatus for Evaporating Liquids in the manufacture of salt and sugar; and I do hereby declare that the following is a full and exact description thereof, reference being had to the accompanying drawings, and to the letters of reference marked thereon.

My invention relates to an improvement in apparatus for evaporating saline and saccharine liquids in the manufacture of salt and sugar; and consists in the combination of heaters, boiling-pans, settling and granulating vats, combined, arranged, and operating with relation to each other, so that the saline or saccharine liquid is heated and evaporated with great facility, with economy of fuel and labor.

To enable others skilled in the art to make and use my invention, I will proceed to describe its construction and operation.

In the accompanying drawings, which form part of my specification, Figure 1 is a top view or plan of my improvement in evaporating apparatus, representing the draft-flue of the boiling-pan and settling-vat removed. Fig. 2 is a side elevation of the apparatus. Fig. 3 is an end elevation of the same. Fig. 4 is a side elevation of the same, and a vertical section of the heaters at line *y* of Fig. 1. Fig. 5 is a vertical section of one of the heaters, and a vertical and transverse section of the boiling-pan and settling and granulating vats at line *y'* of Fig. 1. Fig. 6 is a vertical and longitudinal section of the boiling-pan at line *y''* of Fig. 3.

In the accompanying drawings, A represents a salt-well and derrick. The well A is furnished with a pipe, *a'*, for conveying the saline liquid to the desired elevation, the flow of liquid up through pipe *a'* being accomplished by a pump or the upward flow of the well. The liquid flows from the upper end of pipe *a'* into a receiver, *c'*, on the upper end of the pipe *b'*, the lower end of which enters the chamber C of the heater B. The end of the pipe *b'* which is within the chamber C of the heater B is provided with a distributing-head, *d'*, which dis-

tributes liquid in a series of currents, causing a constant agitation of the liquid in chamber C, which will cause the liquid to heat more uniformly.

By this arrangement of the pipes *a'* and *b'* the liquids will be subjected to pressure while in the chambers and pipes of the heaters B and D, hereinafter described. B represents a heater, having a receiving-chamber, C, and a chamber, *f'*, for steam, and a spiral channel, *e*, for the saline or saccharine liquid, which channel communicates, by means of a pipe, *f*, with a spiral channel, *g*, of the heater, D, having a fire-chamber, *h*, and stack *i*. The receiving-chamber C communicates with the spiral chamber *g* of the heater D by means of a pipe, *j*. E represents the boiling-pan, having a rod, 3, the ends of which are attached to the ends of the pan. From the rod 3 radiate rods 4, which are attached to the sides and bottom of the pan for the purpose of bracing it. The boiling-pan is surrounded by an air-space, 5, which communicates with air-heaters 6 and 7, heated by the fire on grate 8. The air-heater 6 serves as a bridge-wall for the furnace 9. Above the boiling-pan is a steam-drum, *k*, which communicates by means of pipe *o* with a heater, consisting of pipes *l*, arranged between two chambers, *m*. This heater is arranged in chamber F, which is above the boiling-pan E, and between it and the heater are three collecting-pans, *n*, communicating with a pan, *p*, which communicates with the settling-vat H by means of a pipe, *t*. The chamber F communicates with air-space 5 through the medium of openings *r* between the collecting-pans *n*.

Above the heater in chamber F are arranged three distributing-pipes, *s*, the lower sides of which have openings for distributing the liquid in thin sheets or streams over the pipes *l*. The distributing-pipes *s* are connected to the pipe *n'*, which is connected to the pipe *t'*, which communicates with the boiling-pan at *s'*. The chamber F is provided with a flue, G, for carrying off the vapor and conducting heated air upward through the descending liquid as it flows over the heated pipes *l* in chamber F. The settling-vat H is divided into three narrow compartments, which communicate with each other, having spaces

u between them for the passage of air. Above the settling-vat H is a vapor-chamber, I, having doors *v* for observing the condition of the liquid in the vat, and also as an entrance to it. The chamber I is furnished with a flue or stack, J, for carrying off vapor, which is facilitated by the upward draft of air through the openings *u* and *w*. The settling-vat is furnished with heating-pipes *x*. The granulating-vat K is furnished with heating-pipes *y*, and agitators L, which consists of a pipe bent so as to form a half-circle, one end of which pipe is made bell-mouthed, as indicated at *a*. To the agitator L at *b* are connected steam-pipes *c*, which communicate with the steam-pipe *d*, which communicates with the steam-pipe *o* of the steam-drum *k*. To the steam-pipe *o* is connected a pipe, *e'*, which communicates with the chamber *f'*, which surrounds the chamber C of the heater B.

The pipe *g'* is connected to the upper part of the spiral channel *e* of the heater B, and to the drum *h'* under the back end of the boiling-pan E, the drum *h'* communicating with the boiling-pan by means of the vertical pipe *i'*. The heating-pipes *x* and *y* of the settling and granulating vats H and K communicate with the steam-pipe *d*. The heating-pipes *x* and *y* are connected to a pipe, *j'*, for carrying off the products of condensation. The settling-vat H communicates with the granulating-vat K by means of a pipe, *k'*. The furnace of the boiling-pan E is furnished with a stack, R. The boiling-pan E is provided with indicators *m'* for the purpose of indicating the quantity of liquid in it.

From the foregoing description and reference to the accompanying drawings, the skillful mechanic will readily understand the construction of the several parts of my improvement, and the relation they bear to each other. I will therefore proceed to describe the operation.

The saline water flows from pipe *a'* into pipe *b'*, from which it flows from the head *d'* into chamber C of heater B, where it is heated by the steam in the chamber *f'*. The saline water then flows from the chamber C through pipe *j* into the spiral chamber *g* of the heater D, fire being made in the fire-chamber *h*, the liquid in the spiral chamber *g* is heated to a high degree, and then flows from the upper part of the channel *g* down through pipe *f* into the spiral channel *e* of the heater B, and passing upward through the channel *e* enters pipe *g'*, and flowing down through it enters the drum *h'*, from which it passes up through the vertical pipe *i'*, entering the boiling-pan E, where it is subjected to the boiling process by the action of fire in the furnace *g*. The steam generated by the boiling of the liquid in the pan E forces it up pipe *h'* and into the pipes *n'* and *s*, and flowing from the openings of pipes *s* over the pipes *l*, (which are heated by steam in them,) and flowing down over the pipes *l* an upward current of heated air comes in contact with the downward-flowing liquid,

thereby facilitating the evaporating process. The liquid flowing over the heated pipes *l* falls into the collecting-pans *n*, from which it flows into the pan *p*, from which it flows through pipe *t* into the settling-vat H, where it is heated by pipe *x*, the vapor passing off and up through the stack J. The liquid flows from the settling-vat H through pipe *k'* into the granulating-vat K, where it is heated through the medium of pipes *y*, being kept in continuous motion by means of the agitators L, which, by the action of the steam flowing through pipe *c*, causes the liquid to enter the bell-mouthed pipe *a* of the agitators and flow out at *b''*, as indicated by the arrows in Fig. 1. By thus keeping the liquid in a constant state of agitation near its surface the evaporating process is greatly facilitated, and the granulation and precipitation promoted. The granulated salt is removed from the vat K and manipulated in the usual manner. The steam generated by boiling the liquid in the pan E enters the steam-drum *k*, passes from it through pipe *e* into the chamber *f'* of the heater B, and also through pipe *o* into the chambers *m* and pipes *l*, and also through the pipe *d*, heating-pipes *x y*, and the pipes *c* of the agitators L. The results of condensation of steam is carried off by the pipe *j'*. The several pipes hereinbefore described are provided with valve-cocks for regulating the flow through them.

From the foregoing description of the operation of my improvement it will be observed that the liquid is subjected to hydrostatic pressure during the operation of heating and boiling it, and that it is subjected to heat while being distributed throughout the several parts of the apparatus, and also to currents of heated air, and that the vapor rising from the vats is rapidly carried off, and that the vapor and heat of the boiling-pan are utilized; and, finally, the labor of agitating the liquid in the granulating-vat is dispensed with, and the heat used in the operation of evaporating the liquid is fully utilized.

Having thus described my improvement, what I claim as my invention is—

1. In an evaporating apparatus, the heater B, having chambers C *f'*, and spiral channel *e*, in combination with the heater D, having spiral channel *g*, and the boiling-pan E, substantially as herein described, and for the purpose set forth.

2. In an evaporating apparatus, the boiling-pan E, surrounded by the chamber *h'* for the passage of heated air, in combination with the pipe *h'* and distributing-pipes *s*, and a heater, consisting of chamber *m* and pipes *l*, substantially as herein described, and for the purpose set forth.

3. In an evaporating apparatus the heater, consisting of chambers *m* and pipes *l*, in combination with the collecting-pans *n* and settling-vat H, substantially as herein described, and for the purpose set forth.

4. The settling-vat H, having vapor-cham-

ber I, stack J, and air-passages *u* and *w*, substantially as herein described, and for the purpose set forth.

5. In an evaporating apparatus, the distributing-pipes *s*, and heater, consisting of chambers *m* and pipes *l*, inclosed in the chamber F, having a stack, G, substantially as herein described, and for the purpose set forth.

6. In an evaporating apparatus, the supply-pipe *a'* and stand-pipe *b'*, the latter provided with the distributor *d'* on its lower curved end, in combination with the heater

B, whereby the saline and saccharine liquid is conveyed to the chamber C of the heater and subjected to hydrostatic pressure, substantially as herein described, and for the purpose set forth.

7. The semicircular agitator L, provided with a steam-supply pipe, *e*, substantially as and for the purpose described and set forth.

JAS. E. WEAVER.

Witnesses:

JAMES J. JOHNSTON,

A. H. JOHNSTON.