

C. ABEL.

BUNG MACHINE.

No. 182,786.

Patented Oct. 3, 1876.

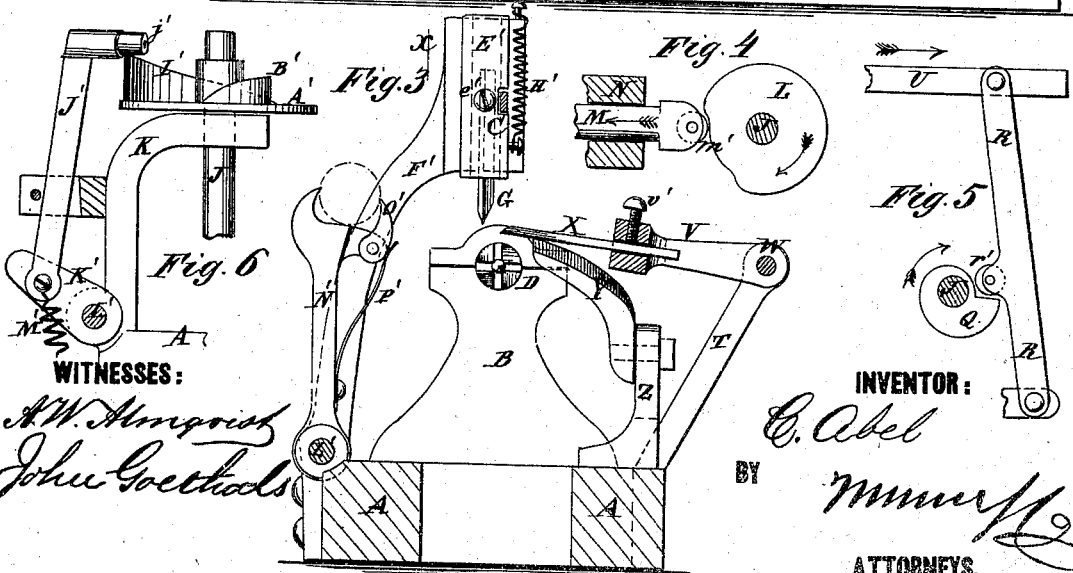
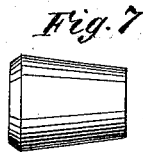
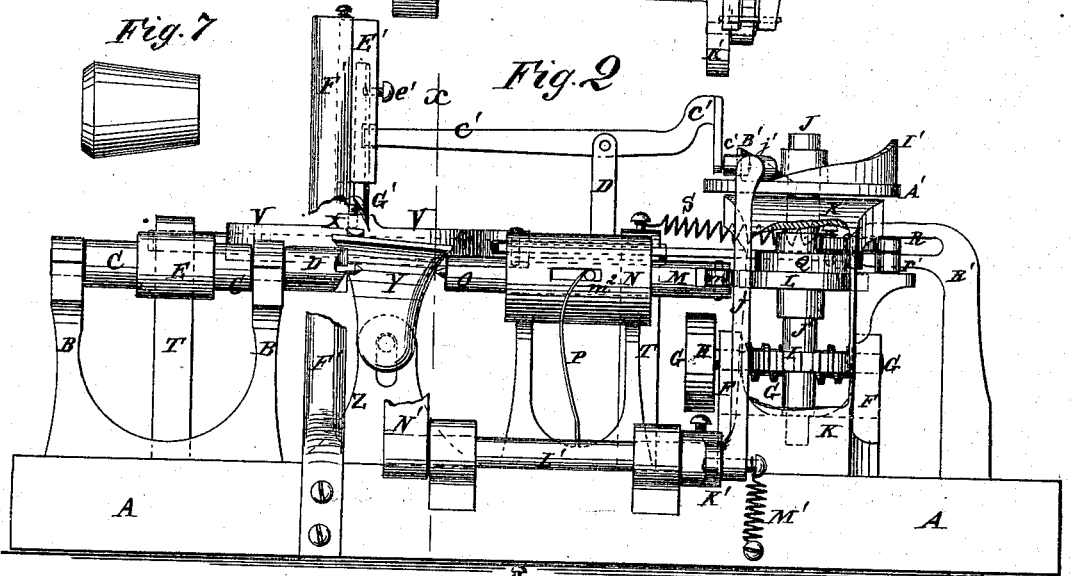
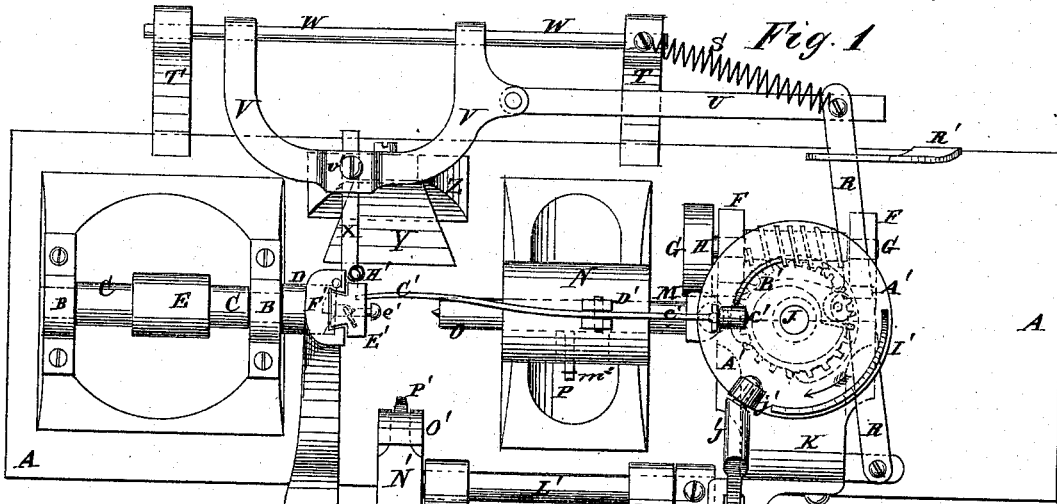

WITNESSES:

*A. W. Amgroich*  
*John Goethals*

INVENTOR:

*C. Abel*

BY

*Wm. M. ...*  
ATTORNEYS.

# UNITED STATES PATENT OFFICE.

CHARLES ABEL, OF BROOKLYN, NEW YORK.

## IMPROVEMENT IN BUNG-MACHINES.

Specification forming part of Letters Patent No. 182,786, dated October 3, 1876; application filed July 31, 1876.

### *To all whom it may concern:*

Be it known that I, CHARLES ABEL, of Brooklyn, in the county of Kings and State of New York, have invented a new and useful Improvement in Bung-Machines, of which the following is a specification:

Figure 1 is a top view of my improved machine. Fig. 2 is a front view of the same, parts being broken away to show the construction. Fig. 3 is a vertical cross-section of the same taken through the line *x x*, Fig. 2. Fig. 4 is a detail view of the device for operating the center, to clutch and release the bung. Fig. 5 is a detail view of the device for operating the cutter that gives the taper to the bung. Fig. 6 is a detail view of the device for operating the cutter that bevels the head of the bung. Fig. 7 represents a completed bung.

Similar letters of reference indicate corresponding parts.

The object of this invention is to furnish an improved machine for forming bungs with tapering sides and beveled heads from wooden cylinders of the proper length, and which shall be simple in construction, convenient in use, and reliable in operation.

The invention consists in the combination of the plate, the cam, the sliding bar, the arm, the shaft, and the blank-holder with the shaft and the centers for carrying the blank bung forward to said centers; in the combination of the cam, the lever, the spring, the connecting-rod, the U-frame, the cutter, and the rod with the shaft and the centers, for operating the said cutter to taper the bung, and in the combination of the plate, the cam, the lever, the sliding cutter-holder, the cutter, and the spring with the shaft and the centers, for operating the said cutter to bevel the bung-heads, as hereinafter fully described.

A is the bed-plate of the machine, to which, near one end, are attached two brackets, B. In bearings in the brackets B revolves a shaft, C, to the forward end of which is attached the center D, that rotates the bung by means of teeth formed upon it. To the shaft C is attached a pulley, E, to receive the band by which the said shaft is driven from any convenient power. To the bed-plate A, near its other end, are attached two brackets, F, in bearings, attached to which revolves a shaft,

G, to one end of which is attached a pulley, H, to receive the belt by which it is driven from any convenient power. Upon the shaft G is formed a screw-thread, which meshes into the teeth of a screw-wheel, I, attached to a vertical shaft, J. The shaft J revolves in bearings attached to the bracket K, and to it is attached a cam, L, against which rests a small friction-wheel, *m*<sup>1</sup>, pivoted to the end of the shaft M, that slides longitudinally in bearings in a bracket, N, attached to the bed-plate A, which bearings are made so long as to keep the said shaft always in the same line. Upon the forward end of the shaft M is formed the center O, upon which the end of the bung turns while being operated upon. To the shaft M is attached an arm, *m*<sup>2</sup>, that passes out through a slot in the bearings of said shaft, and to the outer end of which is attached the upper end of a spring, P. The spring P is attached to the bracket N, and is designed to draw back the center O, when the shaft M is released from the cam L, to allow the completed bung to drop. To the vertical shaft J is attached a cam Q, against the face of which rests a small roller, *r*<sup>1</sup>, pivoted to the lever R. One end of the lever R is pivoted to the bracket K, and its other or free end rests in a slot in a guide-bar, R', attached to the bed-plate A, and is held forward by a spiral spring, S, the other end of which is attached to a bracket, T, attached to the bed-plate A. To the free end of the lever R is also pivoted the end of the connecting-rod U, the other end of which is pivoted to the arm of a U-frame, V. The ends of the arms of the U-frame V slide and turn upon a rod, W, the ends of which are attached to the brackets T. In the bend of the frame V is formed a socket to receive the cutter X, which is secured in place in said socket by a set-screw, *v*<sup>1</sup>. The cutter X cuts the taper upon the bungs, is held down to its work by the weight of the frame V, and rest upon the edge of the guide Y, which is secured by a bolt to a slotted standard, Z, attached to the bed-plate A, so that, by loosening the said bolt, the guide Y may be adjusted to give any desired taper or size to the bungs. To the upper end of the shaft J is attached a plate, A', to which, about midway between its center and edge, is attached a cam, B'. At each revolution of the plate A' the cam B'

comes in contact with a roller, *e'*, pivoted to the end of the lever *C'*, which is pivoted to a stud, *D'*, and its other end is attached to the holder *E'*, which slides in a dovetailed groove in the bracket *F'*, attached to the bed-plate *A*, and in which the cutter *G'* is secured by a set-screw, *e'*. The holder *E'* is moved down to bring the cutter *G'* in contact with the head of the bung by the lever *C'*, and is raised to withdraw the cutter *G'*, when its work is done, by the spiral spring *H'*, one end of which is attached to the said holder *E'*, and its other end is attached to the bracket *F'*. To the wheel or plate *A'*, close to its edge, is attached a cam, *I'*, which, at each revolution of the plate *A'*, comes in contact with the small roller *j'*, pivoted to the end of an arm formed upon the upper end of a bar, *J'*, that slides up and down in a guide attached to the bracket *K*, and its lower end is pivoted to an arm, *K'*, rigidly attached to the end of a shaft, *L'*. The bar *J'* is held down, except when raised by the cam *I'*, by a spiral spring, *M'*, one end of which is attached to the end of the said bar, and its other end is attached to the bed-plate *A*. The shaft *L'* works in bearings attached to the bed-plate *A*, and to its other end is attached the lower end of an arm, *N'*, the upper end of which is concaved upon its forward side, to adapt it to serve as a jaw for holding the bung-blank. The bung-blank is held in place upon the jaw of the arm *N'* by a jaw, *O'*, which is pivoted to the arm *N'*, and is held forward to clamp the bung-blank by a spring, *P'*, attached to the arm *N'*. The spring *P'* is so formed that it will yield to allow the jaw *O'* to be turned back and withdrawn from the bung-blank when said blank has been clamped between the centers *P O*.

In using the machine a bung-blank in the shape of a cylinder of the proper length is placed in the holder *N' O' P'*, which holder is

then moved forward by the cam *I'*, bringing the bung-blank between the centers *D O*. As the blank comes into position between the centers *D O* the sliding center *O* is forced forward by the cam *L* and the holder *N' O' P'* is drawn back by the spring *M'*. The cutters *X G* are now operated by the cams *Q B'* to taper and bevel the bung. As the cutters *X G* complete their work they are drawn back by the springs *S H'*, and at the same time the center *O* is drawn back by the spring *P*, and the completed bung drops. The holder *N' O' P'* then moves forward with another blank, and so on, the whole operation being automatic, except the single act of placing the blanks one at a time in the holder *N' O' P'*.

Having thus described my invention, I claim as new and desire to secure by Letters Patent—

1. The combination of the plate *A'*, cam *I'*, sliding bar *J'*, arm *K'*, shaft *L'*, spring *M'*, and holder *N' O' P'* with the shaft *J* and centers *D O*, for carrying the blank bung forward to said centers, substantially as herein shown and described.

2. The combination of the cam *Q*, the lever *R*, the spring *S*, the connecting-rod *U*, the U-frame *V*, the cutter *X*, and the rod *W* with the shaft *J* and the centers *D O*, for operating the said cutter to taper the bung, substantially as herein shown and described.

3. The combination of the plate *A'*, the cam *B'*, the lever *C'*, the sliding cutter-holder *E'*, the cutter *G'*, and the spring *H'* with the shaft *J* and the centers *D O*, for operating the said cutter to bevel the bung-heads, substantially as herein shown and described.

CHARLES ABEL.

Witnesses:

JAMES T. GRAHAM,  
JAMES H. HUNTER.