

M. BLAKEY.

ROLLS FOR WELDING AND FINISHING TUBING.

No. 182,795.

Patented Oct. 3, 1876.

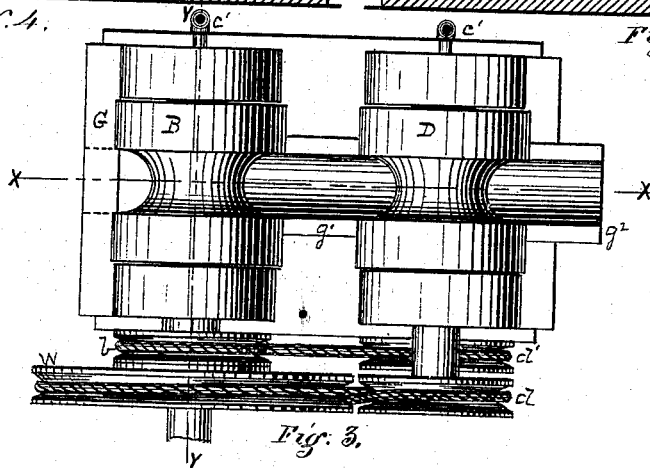
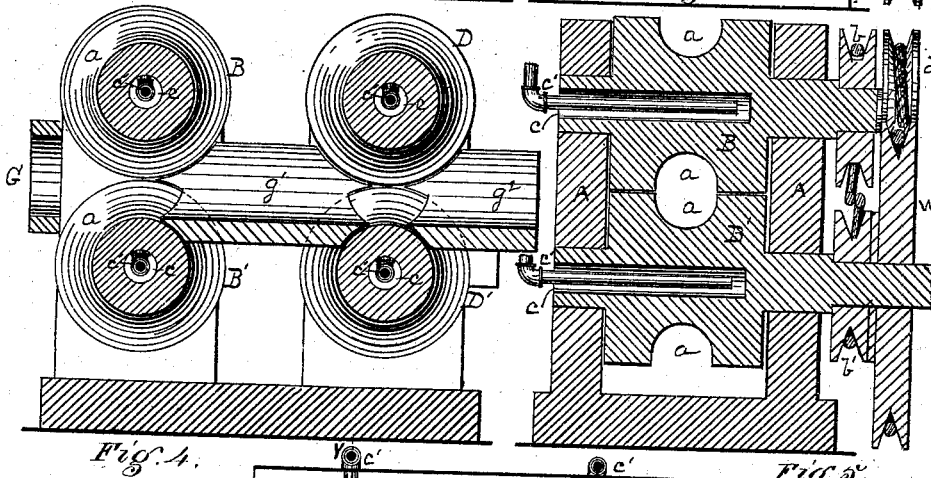
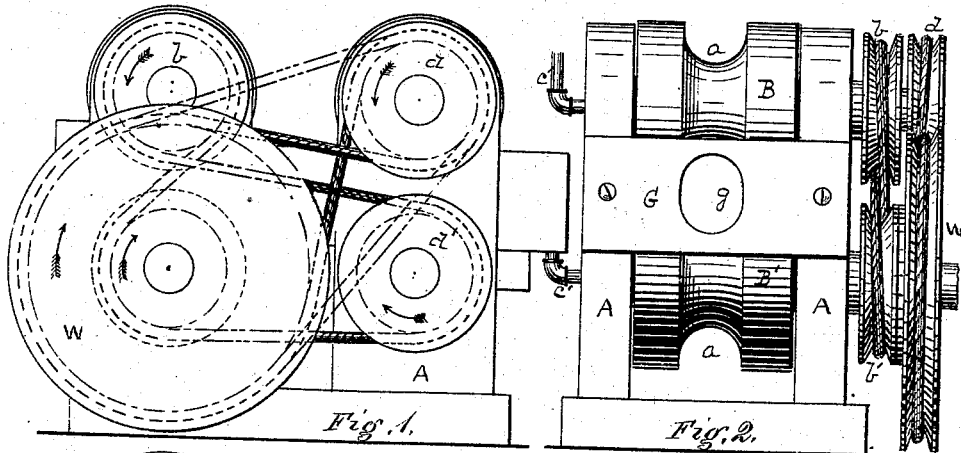

Witnesses
J. J. Weibel
C. L. Parker

Inventor: *Mildred Blakey*
 By *George H. Christy*
 his Atty

UNITED STATES PATENT OFFICE.

MILDRED BLAKEY, OF ETNA BOROUGH, PENNSYLVANIA, ASSIGNOR TO HIMSELF, GEORGE A. CHALFANT, AND JOHN L. ROBERTSON, OF SAME PLACE.

IMPROVEMENT IN ROLLS FOR WELDING AND FINISHING TUBING.

Specification forming part of Letters Patent No. 182,795, dated October 3, 1876; application filed August 24, 1876.

To all whom it may concern:

Be it known that I, MILDRED BLAKEY, of Etna Borough, county of Allegheny, State of Pennsylvania, have invented or discovered a new and useful Improvement in Pipe-Rolls; and I do hereby declare the following to be a full, clear, concise, and exact description thereof, reference being had to the accompanying drawing, making a part of this specification, in which—like letters indicating like parts—

Figure 1 is a side elevation of my improved machine, illustrating more particularly the motions and relative speeds of the rolls. Fig. 2 is a front or feed end elevation. Fig. 3 is a top or plan view. Fig. 4 is a sectional view through *x x*, Fig. 3; and Fig. 5 is a sectional view through *y y* of Fig. 3.

The rolls referred to in connection with the present invention are particularly designed for effecting or perfecting the weld of butt-welded pipe; and since in this operation the pipe or folded skelp must be very hot, it becomes important to provide some artificial means for keeping the rolls from becoming unduly heated. This is one object of my present invention. Another is to close up, or fill up, or give a more perfect finish to the joint along the line of weld. This I do by giving to a roll which acts on the joint a motion faster or slower than the feed, or a motion the reverse of the feed, so that such roll shall operate on the joint by a rubbing or grinding action. I have found, by practical use, that such action on the hot exterior lips of the joint tends to bring the lips together; or, in other words, to fill up the slight groove which would otherwise exist between them, and give to the pipe a more perfect finish and appearance.

The machine is mounted in any suitable housing, A. An entering feed-guide is shown at G, with an opening, *g*, suitable for the feeding therein of the folded skelp or pipe with the joint uppermost. Two pairs of grooved rolls are employed, B B' and D D', both pairs being horizontal, and being arranged in the same line of feed, with a U-shaped guide, *g*¹, from one pair to the other, and a delivery-guide, *g*²,

on the delivery end of the machine. The grooves *a* in the first pair of rolls are made in the form each of a semi-ellipse—that is, narrower at the roll-periphery than double the depth, but with circular or oval bottoms—the object of which form is to give the sides of the pipe a firm lateral support while the joint is being welded by the vertical action of the rolls. The grooves in D D' are semicircular, or nearly so. The rolls B B' D D' are cast hollow, as shown at *c*, but not with the hollow extending entirely through.

To supply cold water to the interior of these rolls in a constant flow, and thereby prevent them from becoming unduly heated, I carry into each roll-chamber *c* a water-pipe, *c'*, of a little less diameter, and support it in any convenient way, so that the water flowing therefrom will come in contact with the roll, and keep it comparatively cool. This pipe *c'* extends to, or nearly to the closed end of the chamber *c*, as shown in the drawing. The excess of water, becoming heated, will flow out at the open end of the chamber *c* around the pipe *c'* inserted therein. By this construction and arrangement I keep the water off the gear-wheels, where its presence is highly objectionable. As represented in the drawing, the gear-wheels *b b' d'* of three of the rolls, B B' D', are of a uniform size, and as geared to operate with a uniform speed. The third gear-wheel *d* of the roll D, while being of the same size, is operated by a connection with a larger wheel, W, which runs at such speed that the roll D will be operated a little faster than the other rolls, as a result of which it will operate with a rubbing or grinding, as well as a compressing, action on the joint of the pipe which is passing through. I have found, by practical experience, that this rubbing or grinding on the exterior lips of the joint tends to close such lips together, or to fill up the slight groove or score which would otherwise be left therein, and thereby produce a better finished and more perfect job. The same useful results will be secured, though perhaps less perfectly, by making the wheel *w* smaller than the wheel *d*, so that the roll D shall revolve slower than the feed, or by the proper change of the gear-

ing, the roll D may have a reverse motion, fast or slow, as may be preferred.

I do not limit myself as regards the rapidity or direction of revolution of the roll D, provided only that, if revolving in the direction of the feed, it shall move faster or slower than the feed. Any system of gearing suitable for driving such rolls, may be substituted for that shown. Nor is it necessary that the rolls be horizontal, nor even parallel, as they may be vertical, or one pair angularly arranged as regards the other. Also, the grooves may be formed of roll-sections, and one of these sections may have the speed or motion indicated with reference to the roll D, so as to perform the same function in substantially the same manner. With the roll D operating as shown in the drawing, the guide g^2 will prevent or counteract the tendency of the pipe to bend downward and collar on the roll D'.

I am aware that it is not new to make metal rolls hollow, with a water-chamber extending entirely through them; but the escape or leakage of water at the geared ends of the rolls and onto the gearing is highly objectionable; and this evil is one which in my improvement I have overcome by introducing

the water at, and escaping it from, the ungeared end of the rolls, the water-chamber extending only through the working part of the roll.

I claim herein as my invention—

1. In rolls for working hot metals, a water-chamber, c , extending from the ungeared end of the roll, through the working part of the roll, and terminating in a closed end, in combination with a water-supply pipe of less exterior diameter than the chamber, arranged in such chamber, and extending to, or nearly to, the closed end of the chamber, substantially as and for the purposes set forth.

2. The combination of grooved pipe-rolls B B' D D', connected by a guide, and arranged and geared to co-operate in finishing metallic pipe, when one of the rolls, D, which is intended to operate on the joint of the pipe, is geared to operate at a different speed from other rolls, substantially as set forth.

In testimony whereof I have hereunto set my hand.

MILDRED BLAKEY.

Witnesses:

HARRY J. SCHLUTZ,
GEORGE H. CHRISTY.