

E. H. CLINTON & W. A. KNOWLTON.

HARVESTERS.

No. 182,803.

Patented Oct. 3, 1876.

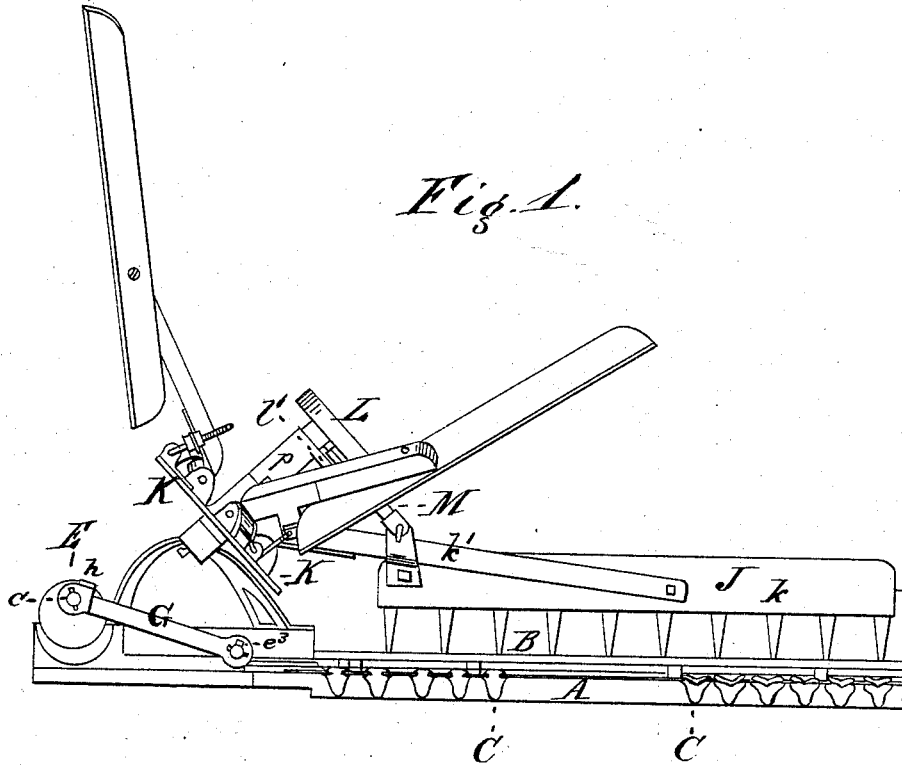

Witnesses  
 W. L. Bennett  
 W. H. Isaacs.

Inventors  
 Edward Henry Clinton  
 William Alford Knowlton  
 by their atty  
 C. S. Penwick

E. H. CLINTON & W. A. KNOWLTON.  
HARVESTERS.

No. 182,803.

Patented Oct. 3, 1876.

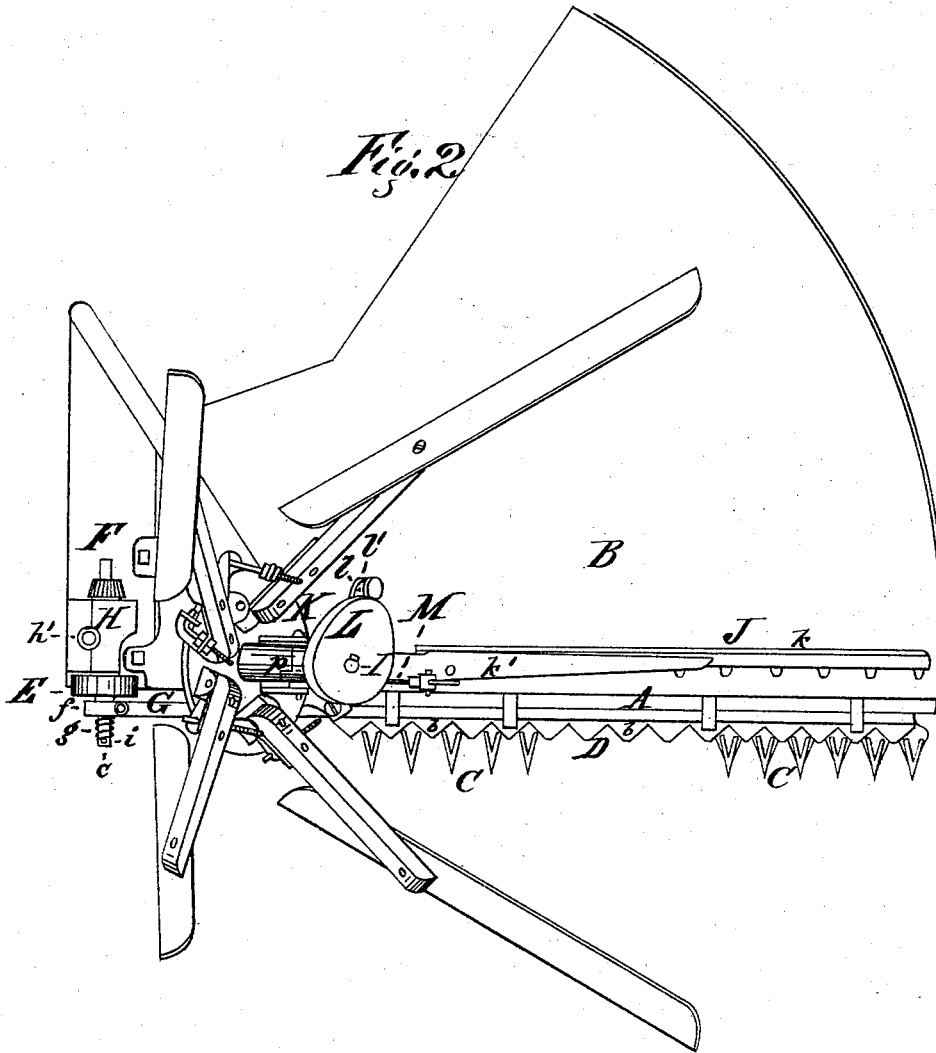

*Witnesses*  
*H. L. Bennett*  
*W. H. Isaacs.*

*Inventors*  
*Edward Henry Clinton*  
*William Alford Knowlton*  
*by their atty*  
*C. S. Remick*

E. H. CLINTON & W. A. KNOWLTON.

HARVESTERS.

No. 182,803.

Patented Oct. 3, 1876.

Fig. 3.

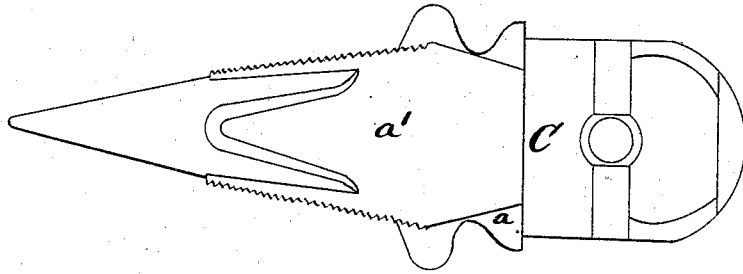
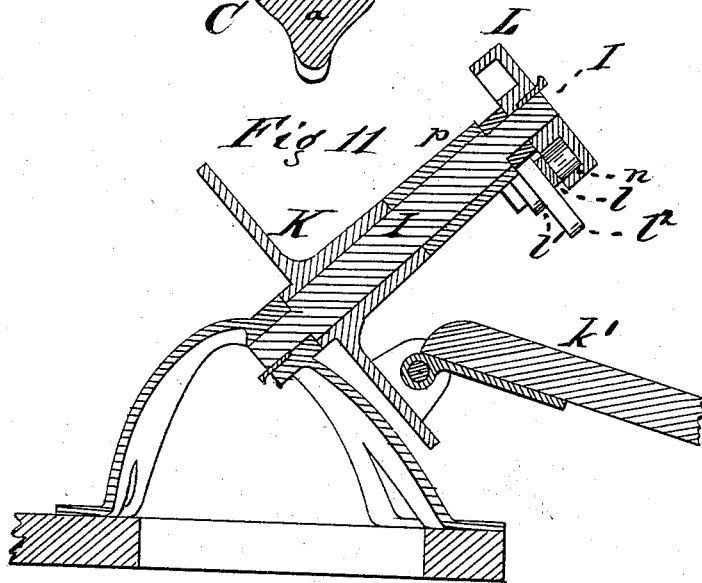

Fig. 4.



Fig. 11.



Witnesses  
 H. L. Bennett  
 W. H. Isaacs

Inventors  
 Edward Henry Clinton  
 William Alfred Knowlton  
 by their atty  
 C. S. Kenwick

E. H. CLINTON & W. A. KNOWLTON.

HARVESTERS.

No. 182,803.

Patented Oct. 3, 1876.

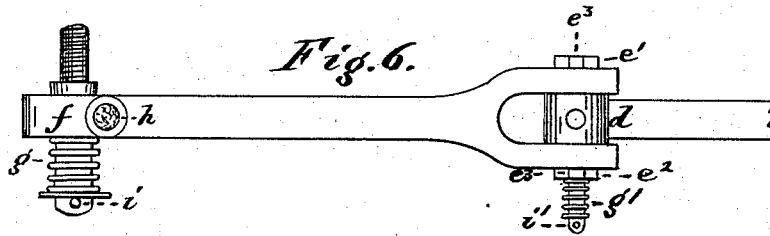

Fig. 6.

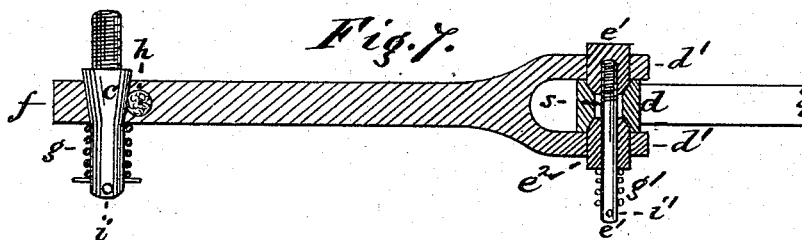

Fig. 7.

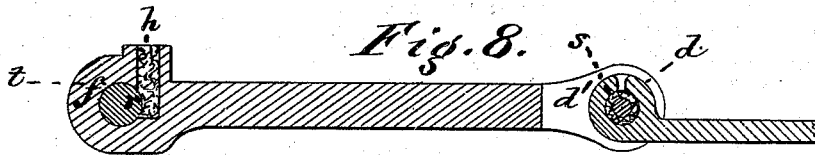

Fig. 8.

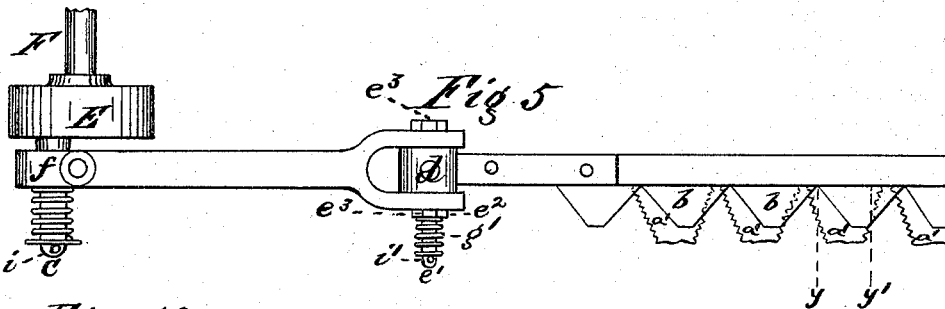

Fig. 5.

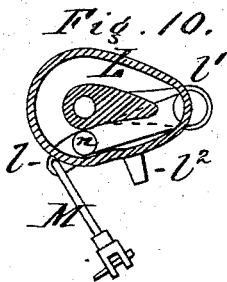

Fig. 10.

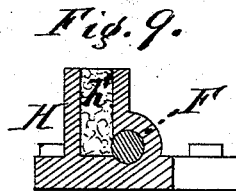

Fig. 9.

Witnesses  
 W. L. Pennington.  
 W. H. Isaacs.

Inventors,  
 Edward Henry Clinton  
 William Alford Knowlton  
 by their atty. C. S. Penwick

# UNITED STATES PATENT OFFICE.

EDWARD H. CLINTON AND WILLIAM A. KNOWLTON, OF ROCKFORD, ILLINOIS,  
ASSIGNORS TO WILLIAM A. KNOWLTON.

## IMPROVEMENT IN HARVESTERS.

Specification forming part of Letters Patent No. 182,803, dated October 3, 1876; application filed  
June 23, 1875.

*To all whom it may concern:*

Be it known that we, EDWARD HENRY CLINTON and WILLIAM ALFORD KNOWLTON, both of Rockford, in the county of Winnebago and State of Illinois, have made an invention of certain new and useful Improvements in Harvesters; and that the following is a full, clear, and exact description of the same.

Our invention has reference to the cutting apparatus of harvesters, the connecting-rod or pitman for driving the same, the reel, and the rake.

Our improvement in the cutting apparatus consists of the combination of reciprocating cutter-blades with guard-fingers provided with ledge-plates, in such manner that the cutter-blades never move entirely off of the ledge-plates in connection with which they operate, whereby the cutting-edges of the cutter-blades and those of the ledge-plates are prevented from cutting into each other.

Our improvements in the connecting-rod or pitman for the cutters consist of the combination of the cutter-eye (or its equivalent or substitute) with the connecting-rod by means of a compound duplex cone-pin, whose members are drawn toward each other by a spring, so that the play produced by wear is taken up automatically.

Our improvements in the reel and rake mechanisms consist of the combinations of the reel-arms and rake-head with an oblique rotating carrier and with an inclined straight standard, the rake being connected with said standard through the intervention of a cam, so that it is caused to oscillate as it rotates, and thus sweep in a curve over the raking-platform.

In order that our invention may be fully understood, we have represented in the accompanying drawing, and will proceed to describe, certain portions of a harvester, which embody our improvements in the best form in which we have embodied them at the present date.

Figure 1 represents a front view of said portions. Fig. 2 represents a plan of the same. Figs. 3 to 11 represent views of parts of the same detached, and upon a larger scale than the preceding figures.

The finger-beam A of the harvester and the

raking-platform B in its rear may be constructed in the usual manner of those of sweep-rake harvesters. The guard-fingers C are attached to the finger-beam, and each is composed of a stock or body, *a*, Figs. 1 and 4, slotted to permit the cutter D to vibrate through it. The part of this body below the cutter-bar is fitted with a ledge-plate, *a'*, which is made of steel, has its edges beveled, as seen in Figs. 3 and 4, and also sickled, and is of such size that its beveled edges overlap those of the body of the guard-finger, thus constituting sickled cutting-edges therefor.

The cutter-bar is provided with blades *b*, of the usual construction, and is caused to reciprocate by means of a rotating crank, E, secured to the crank-shaft F, which is driven in the usual manner by connecting it with a running-wheel of the harvester by means of gearing.

It has been customary with harvesters to make the stroke of the cutter equal to the distance between the centers of the guard-fingers, but the effect of this, when ledge-plates *a'* are used, is to move the cutter-blade off of each of the two ledge-plates with which it co-operates in cutting. Consequently, each cutting-edge of the blade may, by the spring of the cutter, be borne down when it is off of the ledge-plate, the effect of which is that the edge of the cutter-blade is brought against the edge of the ledge-plate when advanced toward it. In order to prevent this occurrence (which would be so detrimental as practically to preclude the use of the ledge-plate) the stroke of the cutter *y y*, Fig. 5, in the machine represented in the drawings, is restricted or made so short (by the position of the crank-pin *e*, relative to the axis of the crank-shaft) that each edge of the cutter-blade *b* never travels off of the ledge-plate *a'*, with which it co-operates; consequently, every part of the edge of the cutter which advances in succession toward the edge of the ledge-plate is guided onto that edge by the preceding portion already on the ledge-plate. Hence it is practically impossible for the edges of the cutter-blade and ledge-plate to cut into each other. The connecting-rod or pitman G, for transmitting motion to the cutter, is subjected to great wear at its con-

necting stub-ends or eyes, and consequently the play of the cutter-eye  $d$ , Figs. 5, 6, 7, 8, upon the connecting-pin  $e$ , and the play of the pitman-eye  $f$  upon the crank-pin  $c$ , speedily become so great as to produce excessive jar. In order to take up the play at the crank-pin as fast as it occurs, the crank-pin journal is made of conical form, (see section, Fig. 7,) and the pitman-eye  $f$  is made of corresponding form. Moreover, a spring,  $g$ , is applied to the crank-pin  $c$ , between the outer side of the pitman and a transverse pin,  $i$ , so that, as wear takes place, the pitman-eye is forced by the spring farther onto the conical crank-pin, and the play is thus taken up.

In order to take up the play at the cutter-eye  $d$ , it is made of duplex conical form, (see section, Fig. 7,) and the forks  $d'$   $d''$  of the pitman are fitted with a duplex cone-pin,  $e^1$   $e^2$ , composed of two parts or numbers,  $e^1$   $e^2$ , one of which,  $e^2$ , is a thimble which slides longitudinally on the other piece  $e^1$ . The portion of each member which traverses the fork  $d'$  of the pitman is cylindrical, so that it may be shoved inward in that fork without affecting the adjustment of either the pitman or the cutter-bar as the conical inner end wears away. The solid pin part  $e^1$  and the thimble part  $e^2$  are prevented from turning in the fork of the pitman by feathers  $e^3$ , which engage in seats formed in the eyes of the forks. The shank of the pin part  $e^1$  is fitted with a spring,  $g'$ , which bears at one end against the head of the thimble  $e^2$ , and at the other against a pin,  $i'$ , in the solid part  $e^1$ . The action of this spring is to force both parts endwise into the eye  $d$  of the cutter-bar, so that as the parts wear the play is taken up automatically. The central portion of the eye  $d$  of the cutter is recessed, as at  $s$ , Figs. 7 and 8, so as to form a lubricating-reservoir, in which sponge or other porous holder of a lubricating material is inserted, so as to prevent it from running to waste, and to apply it by pressure to the wearing-points as long as the sponge is moist.

It will be noticed that the pitman eye or box  $f$  incloses and confines the journal at all sides.

In order that the pitman eye or box  $f$  may be lubricated automatically and with economy, a lubricating-reservoir,  $h$ , is formed at one side of the journal of the crank-pin  $c$ , as seen in section, Figs. 7 and 8. This reservoir communicates with the cavity of the eye or box by an opening,  $r$ , and it is filled with sponge, cotton-waste, or other porous material that will prevent the oil being thrown out by jar. The oil is charged into this lateral lubricating-reservoir, and is applied to the journal by the pressure against it of the porous material holding the oil. If the lubricating-reservoir were made in the top of the box, as is the customary plan, its bottom would be at the line  $t$ , Fig. 8, and consequently it would have to be extended high above the box in order to hold any considerable amount of oil; but by arranging the lubricating-res-

ervoir laterally to the journal, as above described, the reservoir may extend downward the whole diameter of the journal further than it could be on the old plan; consequently much less space is occupied by its upper end, which is a great advantage. The box  $H$ , which incloses and confines the journal of that shaft on all sides for the crank-shaft  $F$ , is constructed in the same manner with the lateral lubricating-reservoir  $h$ , Figs. 2 and 9; and this box is an example of the adaptation of the invention to a fixed journal-box.

The raking-platform  $B$  of the harvesting-machine is quadrantal, being adapted to the use of a sweep-rake,  $J$ , turning round a central axis. The rake-head  $k$  of this rake is constructed in the usual manner, and is fitted with an arm,  $k'$ , which is pivoted to a revolving carrier,  $K$ . This carrier is constructed to revolve upon a straight standard,  $I$ , which is inclined to the plane of the platform  $B$ ; consequently the revolving carrier  $K$  is oblique to that platform, and by reason of this obliquity the rake-arm is held upright, or thereabout, while it is moved forward toward the standing grain.

In order that the rake-teeth may be held down to the platform while sweeping over it, a grooved cam,  $L$ , is secured to the upper end of the inclined standard  $I$ , and the rake-arm is connected with this cam through the intervention of a link-rod,  $M$ , and friction-roller  $n$ , Figs. 10 and 11. The roller is supported and drawn around with the rake-arm by a vibrating arm,  $l$ , which is pivoted to an arm,  $l'$ , that is carried by the sleeve or hub  $p$  of the revolving carrier  $K$ . The vibrating arm  $l$  is supported by a guide,  $l^2$ , which projects from the hub-arm  $l$ .

The rake-arm is pivoted to the carrier  $K$  so that it can oscillate, and the cam-groove is of such form that the arm is caused to swing on its pivot outward from the axis of the inclined standard as the rake-arm is carried rearward over the platform. When the rake reaches the rear of the platform, or thereabout, the friction-wheel arrives at the most protuberant part of the cam, and, as it returns toward the axis of the standard, the rake is drawn toward the standard, so as to travel in the path of a reel-rib as it descends toward the front of the raking-platform. The position of the rake may be regulated by extending or contracting the link  $M$ , which, for this purpose, is constructed with a screwed stem,  $m$ , screwing into the pivot end  $m'$ . The rake is connected with its rake-arm by a screw-bolt,  $q$ , which permits it to be set to move parallel with the raking-platform.

The reel-ribs  $P$  are combined with the same oblique-revolving carrier  $K$  and inclined standard  $I$  that carry the rake. Each of them is connected with the carrier by means of an arm,  $t$ , and a pivot,  $o$ , so that the arms can be moved to adjust the position of the reel-ribs  $P$ ; and the reel-arms are held in any desired position by means of the adjustable brace-rods

or links *w*. The reel-ribs are connected with their respective arms by means of screw-bolts *v*, that permit them to be set at the required angle with the reel-arms to approach the finger-beam properly. The rake and reel-ribs are caused to revolve by means of gearing connecting the revolving carrier K with one of the running wheels, beveled wheels being used to transmit the motion wherever a change of direction is necessary.

We claim as our invention—

1. The combination, substantially as before set forth, of the guard-fingers, the ledge-plates thereof, (one for each guard-finger,) and the cutter-blade, whose range of movement is restricted by the crank, so that it will always overlap both of the ledge-plates with which it co-operates.

2. The combination, substantially as before set forth, of the conical cutter-eye, the duplex cone-pin, and the spring thereof.

3. The combination, substantially as before set forth, of the oblique-revolving carrier, the reel-arms pivoted thereto, and the adjustable

links, whereby the position of the reel-arm relatively to the said carrier can be adjusted and secured.

4. The combination, substantially as before set forth, of the straight inclined standard, the oblique-revolving carrier, the rake hinged on said carrier, and the cam.

5. The combination, substantially as before set forth, of the straight inclined standard, the oblique-revolving carrier, and the reel-rib connected with said carrier.

6. The combination, substantially as before set forth, with the same straight inclined standard and oblique-revolving carrier, of the rake hinged on said carrier, and the reel-rib, also connected thereto.

Witness our hands this 19th day of April, A. D. 1875.

EDWARD H. CLINTON.

WILLIAM ALFORD KNOWLTON.

Witnesses:

R. T. HASLAM,

ALEX. STRACHAN.