

T. F. HALL.

APPARATUS FOR SETTING UP SHIPS' RIGGING.

No. 182,818.

Patented Oct. 3, 1876.

Fig. 1.

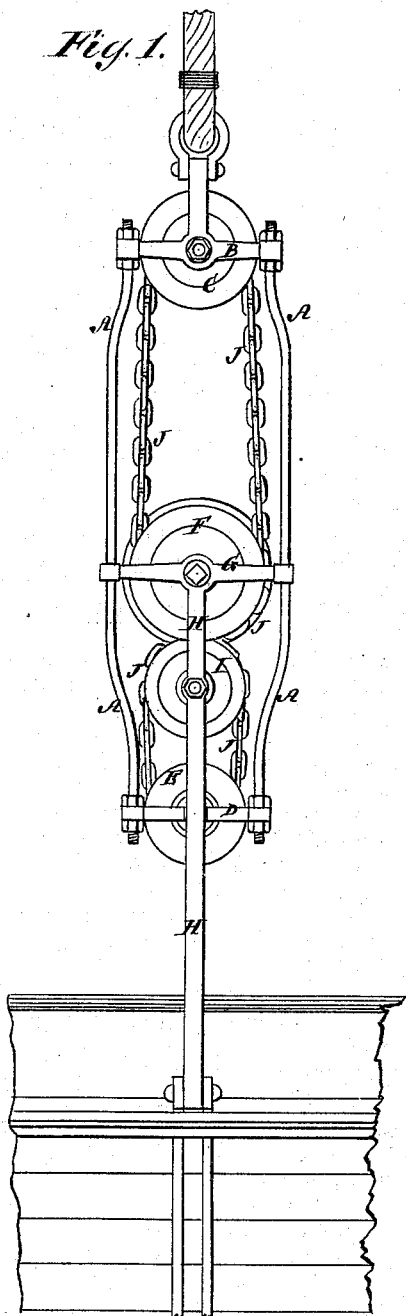

Witnesses:

*E. Hoff*  
*John Coetals*

Fig. 2.

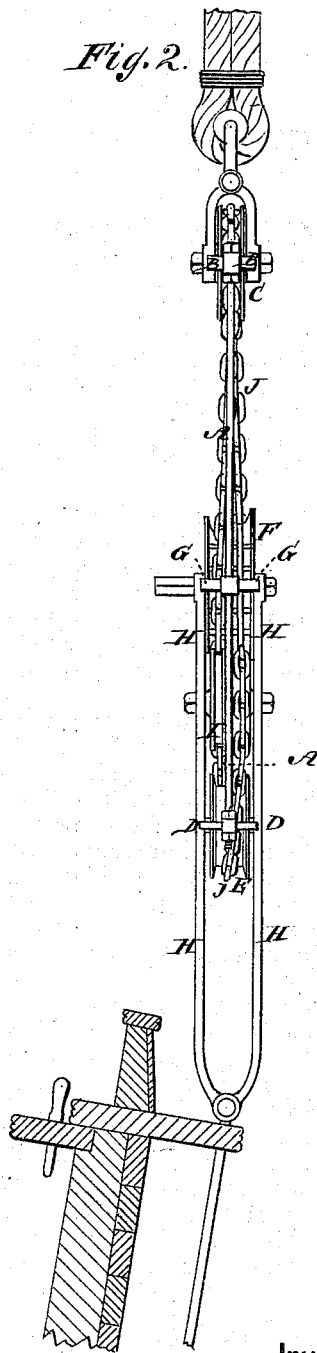

Inventor:

*T. F. Hall*  
Per *Mumt*

Attorneys.

# UNITED STATES PATENT OFFICE.

THOMAS F. HALL, OF OMAHA, NEBRASKA.

## IMPROVEMENT IN APPARATUS FOR SETTING UP SHIPS' RIGGING.

Specification forming part of Letters Patent No. **182,818**, dated October 3, 1876; application filed August 21, 1876.

*To all whom it may concern:*

Be it known that I, THOMAS F. HALL, of Omaha, in the county of Douglas and State of Nebraska, have invented a new and useful Improvement in Apparatus for Setting up Ships' Rigging, of which the following is a specification.

Figure 1 is a side view of my improved apparatus. Fig. 2 is an edge view of the same.

Similar letters of reference indicate corresponding parts.

My invention has for its object to furnish an improved apparatus for setting up ships' rigging and for other uses where great power is required.

The invention consists in the employment of the double chain-pulley of different diameters, in connection with the guide-pulleys, the frame, and the endless chain; in the employment of the guide-rods and their pulleys, in connection with an endless chain and differential pulley; and in the combination of the differential pulley, the guide-pulleys, the frame and guide-rods and their pulleys, and the endless chain with each other, as hereinafter fully described.

A are two guide-rods, the upper ends of which are connected by bars B, to and between which is pivoted a pulley, C. The lower ends of the rods A are connected by bars D, to and between which is pivoted a pulley, E, the pulleys C and E being thus always kept at the same distance apart. F is a double chain-pulley, the two parts of which are of different diameters. The double pulley F is arranged between the cross-bars of the frame G, and journaled in the same. At the ends of said frame are arranged the rods A, which are capable of sliding up and down through the frame. To the middle parts of the bars of the frame G are connected bars H, which project at right angles to said frame. Between the bars H are pivoted pulleys I at such a distance from

the double pulley F that the chain J can pass between them freely. J is an endless chain, which passes over the pulley C. The parts of the chain J pass down upon the opposite sides of the double pulley F, one part passing along the groove of the part of said pulley of greatest diameter, and the other part passing along the groove of the part of the pulley of smallest diameter. The parts of the chain J pass or cross each other between the pulleys F and I, pass down upon the opposite sides of said pulleys I, and around the pulley E. The power is applied to the shaft of the double pulley F. The cross-bars or frame B is connected with the rigging, and the end of the frame H is connected with the side of the vessel. As the pulley F is turned in one direction it moves slowly up the chain J toward the pulley C, drawing the frames G H toward the bars or frame B slowly, but with immense power, the pulleys C E keeping the chain J always taut, and the pulleys I holding the said chain in place upon the pulley F.

Having thus described my invention, I claim as new and desire to secure by Letters Patent—

1. The combination of the double chain-pulley F, of different diameters, with the pulleys I, frame G, and endless chain J, substantially as herein shown and described.

2. The combination of the guide-rods A and pulleys C E with the endless chain J and differential pulley F, substantially as herein shown and described.

3. The combination of the differential pulley F, the pulleys I, the frame G H, the guide-rods A, the pulleys C E, and the endless chain J with each other, substantially as herein shown and described.

THOMAS F. HALL.

Witnesses:

CHAS. HALL,  
JAMES S. FRANCE.