

L. L. HAWORTH.  
CORN-PLANTER.

No. 182,820.

Patented Oct. 3, 1876.

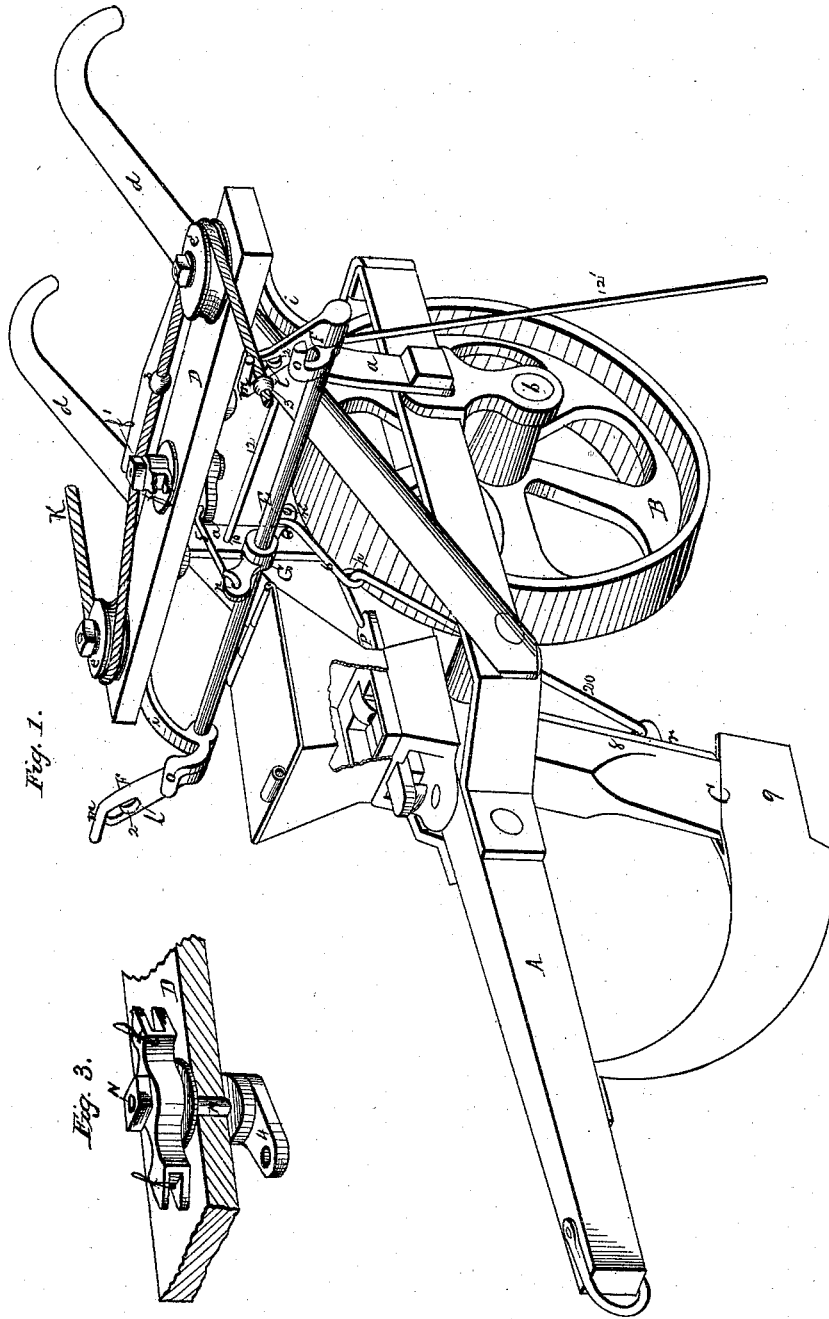

Fig. 1.

Fig. 3.

Witnesses:

Clarence Poole  
J. K. Erans

Inventor:

Lysander L. Haworth  
By A. H. Evans & Co  
Atty's

L. L. HAWORTH.  
CORN-PLANTER.

No. 182,820.

Patented Oct. 3, 1876.

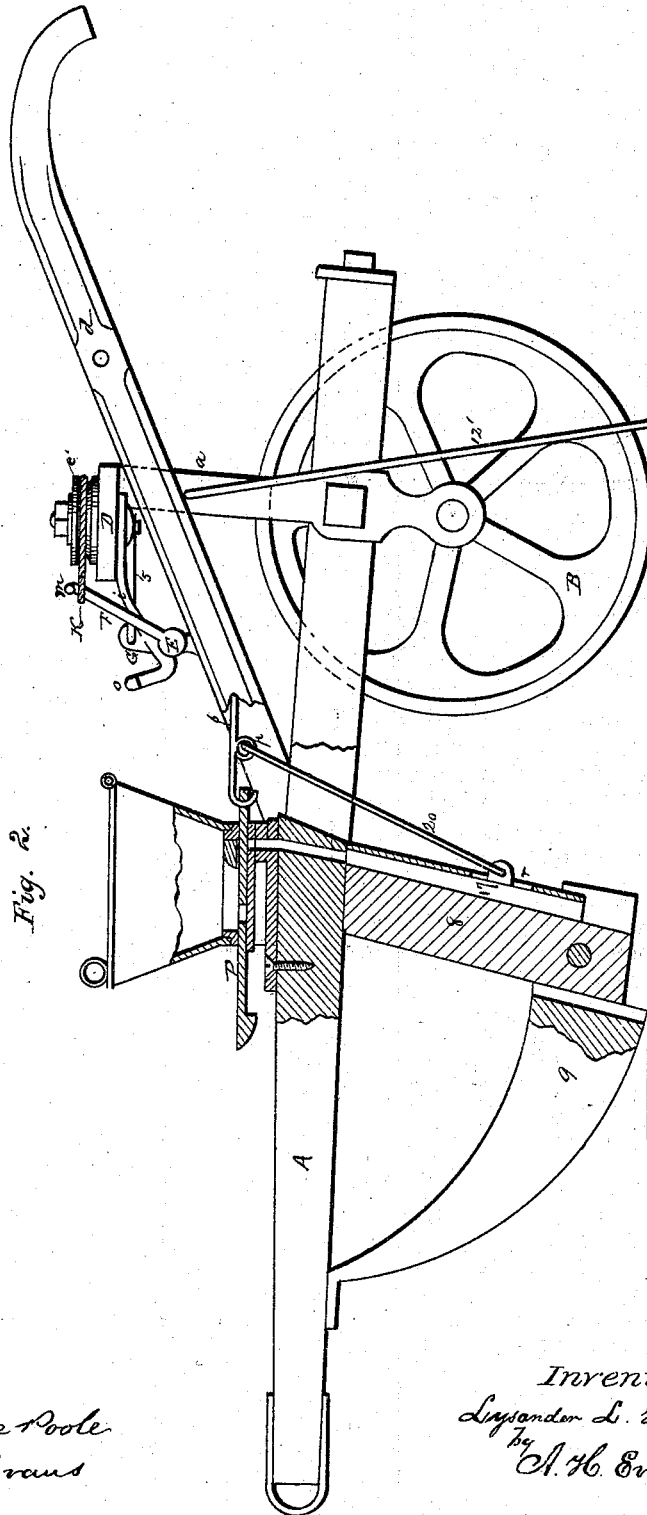

Witnesses:

Clarence Poole  
R. K. Evans

Inventor:

Lindsay L. Haworth  
by  
A. H. Evans & Co.  
Attys.

# UNITED STATES PATENT OFFICE.

LYSANDER L. HAWORTH, OF DECATUR, ILLINOIS.

## IMPROVEMENT IN CORN-PLANTERS.

Specification forming part of Letters Patent No. 182,820, dated October 3, 1876; application filed February 3, 1876.

To all whom it may concern:

Be it known that I, LYSANDER L. HAWORTH, of Decatur, Macon county, in the State of Illinois, have invented certain Improvements in Corn-Planters; and I hereby declare the following to be a full, clear, and exact description thereof, reference being had to the accompanying drawings, making part of this specification, in which—

Figure 1 is a side elevation. Fig. 2 is a top view. Fig. 3 is a detail view.

My invention consists in certain improvements in corn-planters, hereinafter more specifically described and claimed.

In order that those skilled in the art may make and use my invention I will proceed to describe the manner in which I have carried it out.

In the said drawings, A is the beam of a corn-planter, B is the covering-wheel, and C is the colter and spout. From over the axle *b* rise two standards, *a a*, which support a check-roller transverse the handles *d d*. This check-roller consists of a timber, D, fastened direct to the standards *a a*, and bearing-pulleys *e e'*, central vibrating bifurcated arms *f f'*, and forward-projecting arms *i i*, whose ends form journals for a bar, E, which bears in its center a cross-arm, G, having eyes *n n'* at each end. From each end of this journaled bar E project arms F F', bifurcated as at *l*, and one leg turned over to form a hook, *n*. In the slots in the ends of the arms F F' are friction-rollers 2 2, on which runs the rope bearing the buttons 3 3, which operate the planting devices.

On the end of the arms *i i* are stops *o o* to limit the movement of the oscillating arms F F'. The lower end of the stud N which bears the arms *f f'* has on it an arm, 4, which has an eye to receive one end of a link, 5, the other end engaging with the eye *n* in the bar G. Another link, 6, engages one end in the eye *n'* of the cross-arm *g* and the other end with the sliding cut-off P in the bottom of the hopper of the planter.

The link 6 is twisted at *p* so as to form an eye into which engages a link, 20, that leads to an auxiliary grain-feeder, *r*, located in the standard 8 behind the share 9.

Through holes 10 10 in the standards *a a*,

immediately beneath the handles *d d*, is a rod, 12, bent as shown, and swinging loosely, to form legs 12' 12' to support the planter when at rest. These legs, swinging loosely, do not in any way affect the forward or backward movement of the planter.

The operation of the planter is as follows: The planter, being in the position shown in Fig. 1, the buttons 3 on the rope K are placed about as far apart as the distance from the end of the arm F to the end of the arm *f'*, in each instance the rope running in the slot between the bifurcations. When a button comes in contact with the eye or hook *n* it is caught and pulled over in the position seen in Fig. 2. This movement throws the eye *n'* forward, and at the same time, by means of the link 6, forces the slide P in the bottom of the hopper to a position where the grain will drop through into the drill 17, so that as the button slips through the hook *n* passes around the pulley *e'* and engages in the slot in the arm *f*, and by means of the arm 4 and link 5 on the stud N the eye *n* is retracted and the arms F F' are again thrown in the position seen in Fig. 1. The grain is thrown into the furrow by the supplemental dropper *r* actuated by the link 20. It is evident that wooden blocks may be put on the ends of the rod 12 to give it more bearing-surface and shorten the rods accordingly. It is also evident that the rod may be run through the frame around the wheel B, and thus greatly decrease the expense of the legs.

Having thus described my invention, what I claim as new, and desire to secure by Letters Patent, is—

1. The combination of bar E, having cross-arm G and forked arms F F', with sliding cut-off feed P, alternate acting vertical feed *r*, and links 6 and 20, and so arranged and operating substantially as described.

2. The bar E, bearing the oscillating arms F F' and cross-arm G, in combination with a stud, N, having vibrating arms *f*, *f'*, and 4, and the link 5, substantially as and for the purpose set forth.

LYSANDER L. HAWORTH.

Witnesses:

M. HAWORTH,  
W. W. KERR.