

G. P. SALISBURY.

FEEDING DEVICE FOR MACHINES FOR MAKING CARTRIDGE SHELLS.

No. 182,858.

Patented Oct. 3, 1876.

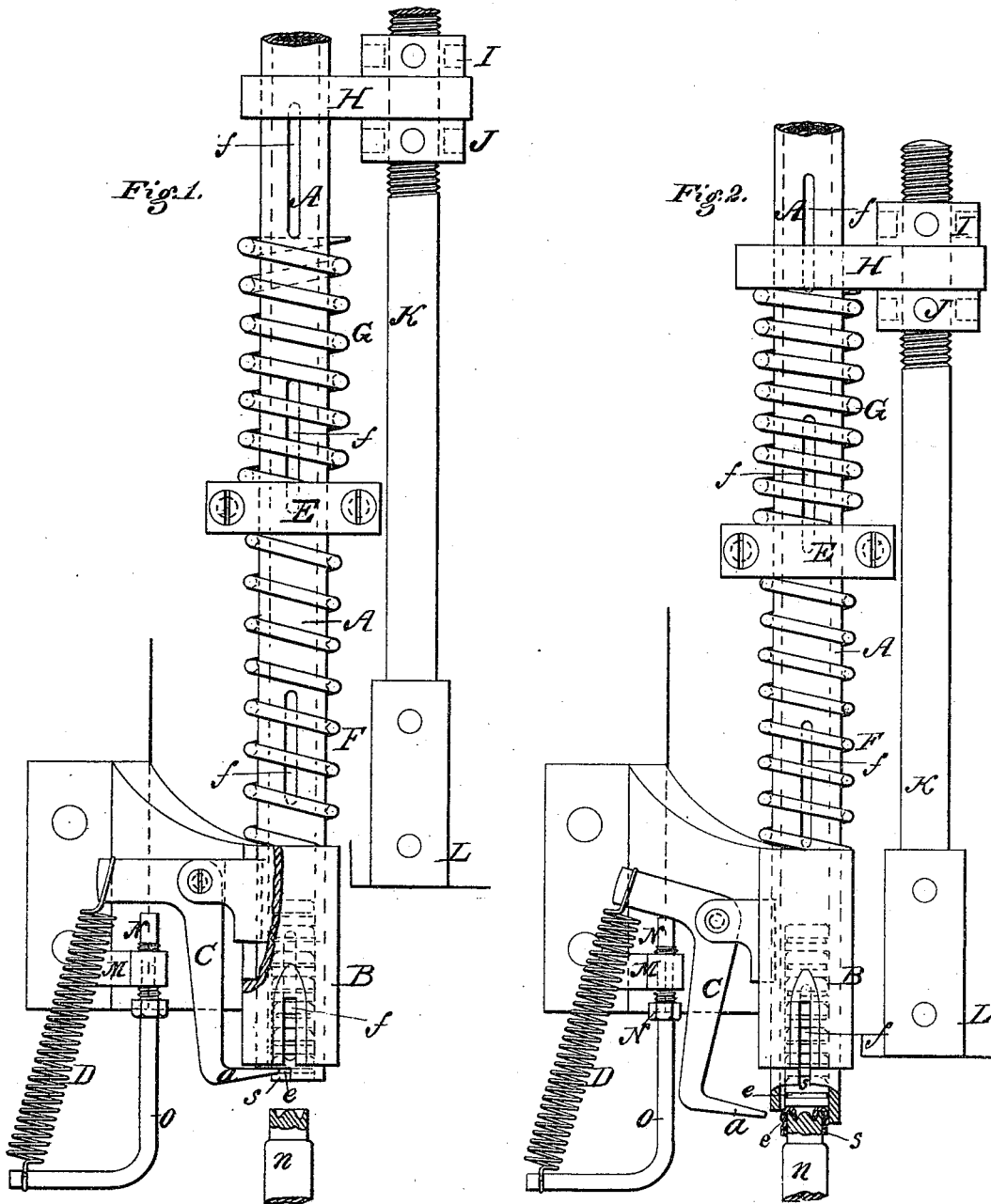

Witnesses:

Down S. Twitchell.  
Will H. Dodge.

Inventor:

Geo. P. Salisbury,  
by Dodge & Co.,  
Attys.

# UNITED STATES PATENT OFFICE.

GEORGE P. SALISBURY, OF NEW HAVEN, CONNECTICUT, ASSIGNOR TO THE WINCHESTER REPEATING ARMS COMPANY, OF SAME PLACE.

## IMPROVEMENT IN FEEDING DEVICES FOR MACHINES FOR MAKING CARTRIDGE-SHELLS.

Specification forming part of Letters Patent No. 182,858, dated October 3, 1876; application filed August 7, 1876.

*To all whom it may concern :*

Be it known that I, GEORGE P. SALISBURY, of New Haven, in the county of New Haven and State of Connecticut, have invented certain Improvements in Feeding Device for Cartridge-Cups, &c., of which the following is a specification :

My invention consists in an improved device for feeding metallic cartridge-shells, re-enforce-cups, and similar articles, it being here represented as adapted to feeding re-enforce-cups for metallic cartridges.

In the drawing, Figure 1 represents a face view of my improved device, it being represented as elevated above the pins on which the cups are to be placed ; and Fig. 2 is a similar view, showing the apparatus in the act of depositing a cup on the upright pin.

The cups to be fed are intended to be placed in the heads of cartridge-shells, for the purpose of strengthening the same, and are first deposited on vertical pins *n*, which are mounted on a rotating dial, said dial being so rotated as to bring the pins *n* successively under the feeding device. As shown in the drawing, this feeding device consists of an upright tube, A, moving in a suitable guide, B, and carrying at or near its lower end a pivoted arm, C, one end of which is connected, by means of a spiral spring, D, to an arm, *o*, formed on the guide B, which guide is rigidly attached to the frame of the machine. The lower end *a* of the arm C is bent in at right angles to the body of the same, as shown in Figs. 1 and 2. The lower end of the tube A is cut away on the side next to the arm C, and the lower end *a* of the arm C extends under the tube A at the point where it is thus cut away. The cups *s* are sometimes formed with a recess, *e*, extending around them, as shown, into which the edge of the gate or lower end *a* of the arm C engages, the cups *s* being fed into the tube A from the upper end. As shown in Fig. 1, this gate *a* presses against the side of the lowest cup *s*, and by holding that, and preventing its dropping out, it, of course, holds up those which are above. Attached to, or formed upon, the guide B is another projecting arm, M, carrying a screw, N, which is adjustable vertically, and is placed below, and

directly in line with, the upper projecting part of the arm C, as shown. Firmly secured to the reciprocating head-block L is a vertical rod; K, which carries, near its upper end, a horizontally-projecting arm, H, the outer end of which arm encircles the tube A. Encircling the tube A is a spiral spring, F, the lower end of which rests upon the upper end of the guide B, and the upper end of which bears against the under side of a clamp, E, which is secured in a fixed position on the tube A. Above the clamp E is another spring, G, somewhat stiffer than the spring F. This spring G also encircles the tube A, and rests at its lower end upon the clamp E, as shown.

As the head-block L descends, the arm H coming in contact with the upper end of the spring G bears the same downward, and the spring G acting upon the clamp E carries it and the tube A, to which it is secured, in the same direction against the action of the spring F, the spring G being, as before stated, somewhat stiffer than the spring F. As the tube A descends, carrying with it the pivoted arm C, the upper end of said arm comes against the end of the screw N, thereby stopping its downward movement, and causing its lower end *a* to be thrown outward from the tube A, and to disengage from the cup *s*, which it previously held. During the downward movement of the head-block L, or previous thereto, the dial is partially rotated, bringing one of the pins *n* directly under the tube A, as shown. At the moment when the cup *s* is released by the arm C the tube A occupies the position shown in Fig. 2, the lower end of the tube coming a short distance down over the end of the pin *n*, and forming a guide by which the cup *s* is carried onto the pin *n*, as shown. As the motion of the head-block L is reversed, the spring F, acting against the under side of the clamp E, causes the tube A to ascend, carrying with it the arm C, the spring D causing the lower end *a* of said arm to swing in toward the tube A as its upper end moves off the screw N.

As shown in Figs. 1 and 2, the screw N is made adjustable, and consequently the movement of the arm C may be regulated and timed by raising or lowering said screw.

The mouth of the tube being open, and the cups S being free at the moment when the head-block L commences its upward movement, the tube will move upward, leaving the lowest cup on the end of the pin *n*, and the next one resting upon it, and so on, until the gate *a* of the arm C again engages with one of the cups *s*, when it and those above it will begin to ascend with the tube A. The movement of the parts is so regulated and timed that the gate *a* shall engage in the recess of the cup next above the one deposited on the pin *n* when the lower edge of said cup comes in line with the lower end of the tube A, as shown in Fig. 1. Although this arrangement is considered preferable in some cases, it is apparent that the gate *a* may be made to pass under the cups instead of engaging in a recess in the side of the same, and may also pass under the end of the tube A instead of working through its side.

By interposing the spring G between the arm H and the clamp E I entirely avoid the jar or shock which would otherwise occur in the rapid manipulation of the machine. I prevent the wear or battering of the arm H and clamp E, which would interfere with the proper movement of the parts which are necessarily required to move with great exactness, and I obtain a spring-pressure on the tube A, which prevents the crushing of the cups when accidentally misplaced, or the breakage of parts.

It will be observed, by reference to Fig. 1, that the arm H does not rest upon the spring G when the head-block is in an elevated position, for the reason that the tube A has a shorter movement than the head-block, and it is necessary that the head-block should move a portion of this distance before commencing to operate the feeding mechanism.

It will readily be seen that, by changing the length of the spring G, the distance between the arm H and clamp E, and, consequently, the movement of the tube A, may be varied. This movement may also be regulated, and probably with greater exactness, by means of the arm H, which, as shown, is held by two nuts, I and J, one above and one below it, by which it may be adjusted to any desired posi-

tion on the rod K, thus accomplishing the same object as by change of springs. It is obvious, also, that instead of the elbow-lever C, with its separate spring D, other devices may be used, and made to operate the same—as, for instance, a long flat spring may be arranged at the side of the tube A, with its lower end bent inward so as to engage against or under the cups in the tube, a cam or other suitable device being arranged to shove it back at the proper instant to release the cups, the principle and mode of operation being substantially the same as above described. So, too, it is obvious that the upper spring G may be dispensed with by arranging the arm H to strike on the clamp E or other projection attached to the tube A; but such arrangement would require a more accurate adjustment of the parts, as the yielding of the spring enables the tube A to operate as desired, even if the arm H, or part which depresses the tube A, should move too far, or not quite far enough.

An apparatus constructed on this plan can be used equally well for feeding cartridge-shells or any similar articles, and thus save the labor of one attendant for each machine.

The shells or cups may either be placed in the tubes beforehand, or any suitable mechanism may be attached to automatically place them in the tube while in operation.

Having thus described my invention, what I claim is—

1. The vertically-reciprocating tube A, having the spring arm or detent C attached thereto, in combination with the stationary stop N, all arranged to operate substantially as described.

2. In combination with the sliding tube A and spring-arm C, the adjustable stop N, for adjusting or regulating the action of the arm C, as set forth.

3. The sliding tube A, provided with the springs F G, of different degrees of strength, arranged to operate substantially as shown and described.

GEORGE P. SALISBURY.

Witnesses:

SAML. KNIGHT,  
ROBERT BURNS.