

S. E. TOMPKINS.
 HARNESS-SADDLE.

No. 182,870.

Patented Oct. 3, 1876.

Fig. 1

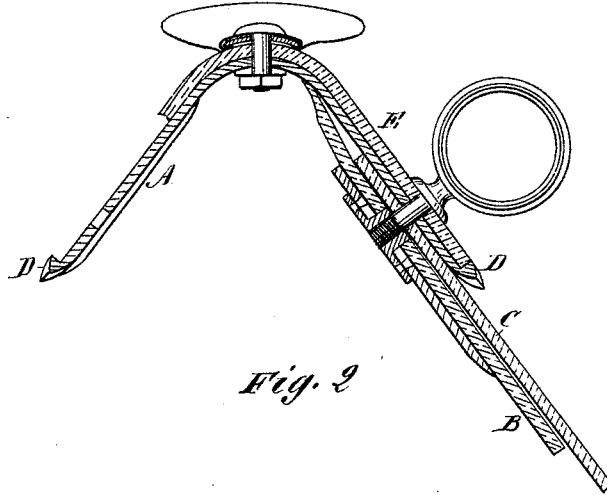

Fig. 2

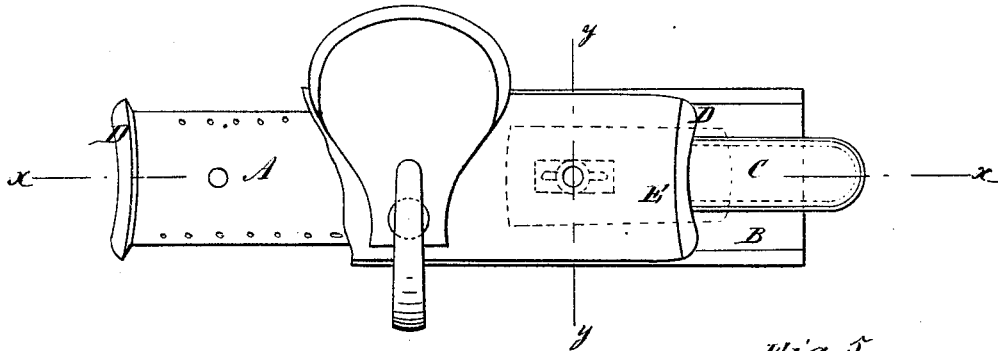

Fig. 3

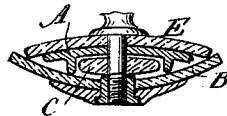

Fig. 5

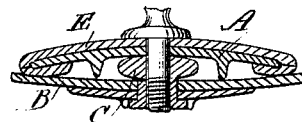
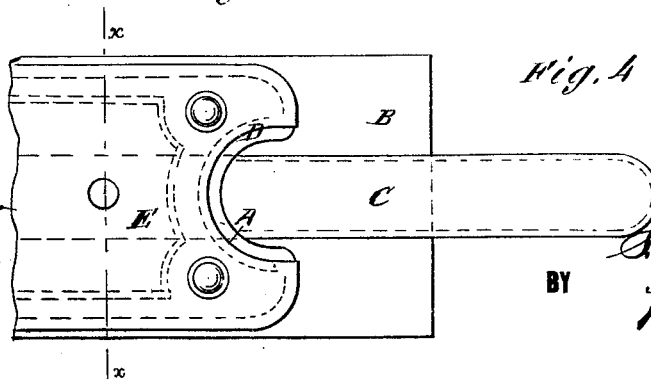

Fig. 4



WITNESSES:

C. Saxeux
J. Gerhals

INVENTOR:

S. E. Tompkins

BY

Wm. M. [Signature]
 ATTORNEYS.

UNITED STATES PATENT OFFICE.

SAMUEL E. TOMPKINS, OF SING SING, NEW YORK.

IMPROVEMENT IN HARNESS-SADDLES.

Specification forming part of Letters Patent No. **182,870**, dated October 3, 1876; application filed July 1, 1876.

To all whom it may concern:

Be it known that I, SAMUEL E. TOMPKINS, of Sing Sing, in the county of Westchester and State of New York, have invented a new and Improved Harness-Saddle, of which the following is a specification:

My invention consists of a rib formed on the ends of the tree-plate to make a finish at the ends of the flap or top leather, the said rib being raised up in the construction of the plate, the upper surface of the leather to be flush with the top of the rib, and being made in concave form to facilitate the finishing of it with a file and furnish room for the back band.

The rib is to be plated with silver, gold, or other fine metal for ornamentation.

Figure 1 is a longitudinal sectional elevation of a harness-saddle with the ends of the tree-plate constructed according to my invention, the section being taken on the line *xx* of Fig. 2. Fig. 2 is a top view. Fig. 3 is a transverse section on line *yy* of Fig. 2. Fig. 4 is a top view, showing an increased curvature. Fig. 5 is a transverse section on line *x* of Fig. 4.

A is the tree-plate, which may be of different forms and be used in different arrangements and with various forms of adjuncts, such as the under plates and the like, but it will preferably be of the convex form shown

in the drawing, for the employment of this improvement, and the under plate B will preferably be concave to admit the backband C between them, as shown. D represents the ribs at the ends of the said plate, which I make in the casting for an ornamental finish to the end of the back strap, and for giving more freedom to the back strap *c* when it emerges from under the plate than it would have if the end of the plate was straight or convex; and also to facilitate the finishing of the rib with the file, I make the end of the plate and the rib more or less concave, as shown. E is the top leather for which the ribs are to make an ornamental finish.

I am aware that a tree-plate has been made thicker at the lower end to afford the requisite strength for a loop formed in it for the connection of a strap, and I do not claim such construction; but

What I claim as new, and desire to secure by Letters Patent, is—

A rib, D, formed on the end of a saddle tree-plate, made with an upward curve to give room for the backband, substantially as herein shown and described.

SAM. E. TOMPKINS.

Witnesses:

JAMES T. GRAHAM,
ALEX. F. ROBERTS.