

W. BOYCE.

VIGNETTING PHOTOGRAPHIC PRINTING FRAMES.

No. 182,886.

Patented Oct. 3, 1876.

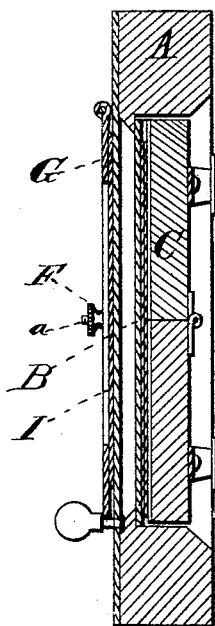
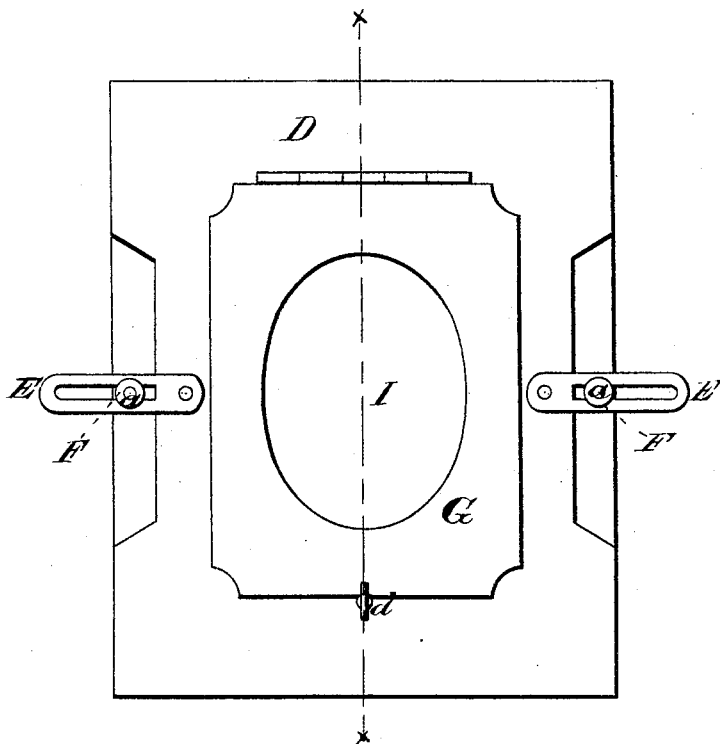

WITNESSES

Robert Emmett
J. F. Acker.

INVENTOR

Washington Boyce
Edmore Smith *Att'ys*

ATTORNEYS

UNITED STATES PATENT OFFICE.

WASHINGTON BOYCE, OF TUSCOLA, ILLINOIS.

IMPROVEMENT IN VIGNETTING PHOTOGRAPHIC PRINTING-FRAMES.

Specification forming part of Letters Patent No. **182,886**, dated October 3, 1876; application filed April 29, 1876.

To all whom it may concern:

Be it known that I, WASHINGTON BOYCE, of Tuscola, in the county of Douglas and State of Illinois, have invented a new and valuable Improvement in the Art of Vignetting Photographs; and I do hereby declare that the following is a full, clear, and exact description of the construction and operation of the same, reference being had to the annexed drawings, making a part of this specification, and to the letters and figures of reference marked thereon.

Figure 1 of the drawings is a representation of a plan view of my improvement in vignetting photographs; and Fig. 2 is a longitudinal vertical sectional view of the same.

My invention relates to plates for printing vignette photographs from the negative; and it consists of an adjustable plate which is attached to the ordinary printing-frame, and is provided with a hinged plate, between which and the adjustable plate the vignette-paper is placed, as will be hereinafter more fully set forth.

In the annexed drawing, A represents the usual printing-frame for holding the negative B while printing from the same, and C is the back for holding the paper to the negative, such parts being constructed in any of the known and usual ways. On the front of the frame A is laid a plate, D, which is provided with a central opening of suitable size. Said plate D is also provided at each side with a slotted arm, E, pivoted thereto. These arms are placed over bolts or screws *a a*, secured in the frame A, and thumb-nuts F F are placed on said bolts or screws for fastening the arms and plate firmly in place. To the plate D is hinged a plate, G, with central opening of same size as that of the adjustable plate D, said plate G being held down to the plate D by a catch or set-screw, *d*. I represents the Waymouth or any other vignette-paper which may be used over the negative B. This vignette-paper is ordinarily tacked down to the printing-frame A. With my invention it is held firmly between the plate D and the plate G.

In negatives the head is sometimes found to be too near to the edge of the glass. In

such case, by my invention the plate D may be adjusted so as to work the vignette as well at the edges as at the center. The plate D is first adjusted on the printing-frame A according to the negative, and fastened by the thumb-nuts F F. The vignette-paper is then laid thereon, and the plate G is closed and fastened by the thumb-screw *d*. These plates D and G are preferably made of brass, but may be made of iron, steel, copper, wood, or any substance answering the purposes herein described.

My advantages are as follows: First, by the use of my invention I save most of the time otherwise occupied by the tacking of the vignette-paper I on the printing-frame A. Second, I save the wear and tear of the printing-frame A, which is unavoidable in tacking down the vignette-paper I. Third, by the use of this plate D the paper I is held more firmly in place than by tacking. My plate also excludes all side light, and lies closer to the frame than the paper when tacked on. Fourth, the adjustment is easier and more perfect by the use of my plate than by the use of the paper, from the fact that there is no tacking or re-tacking of paper, all being free to move until exactly in place, when it can immediately be fastened by tightening thumb-nuts F F at side.

Having thus described my invention, I claim as new and desire to secure by Letters Patent—

1. A vignetting device composed of the plate D, provided with a hinged plate, G, and adjusting devices E E *a a*, substantially as set forth.

2. The combination, with a photographic printing-frame, A, of the apertured plate D, the slotted pivoted arms E E, screws *a a*, thumb-nuts F F, apertured hinged plate G, and the set-screw *d*, substantially as described, and for the purpose set forth.

In testimony that I claim the above I have hereunto subscribed my name in the presence of two witnesses.

WASHINGTON BOYCE.

Witnesses:

E. L. SMITH,
W. H. RUSSELL.