

R. EICKEMEYER.  
FULLING-MILL.

No. 182,909.

Patented Oct. 3, 1876.

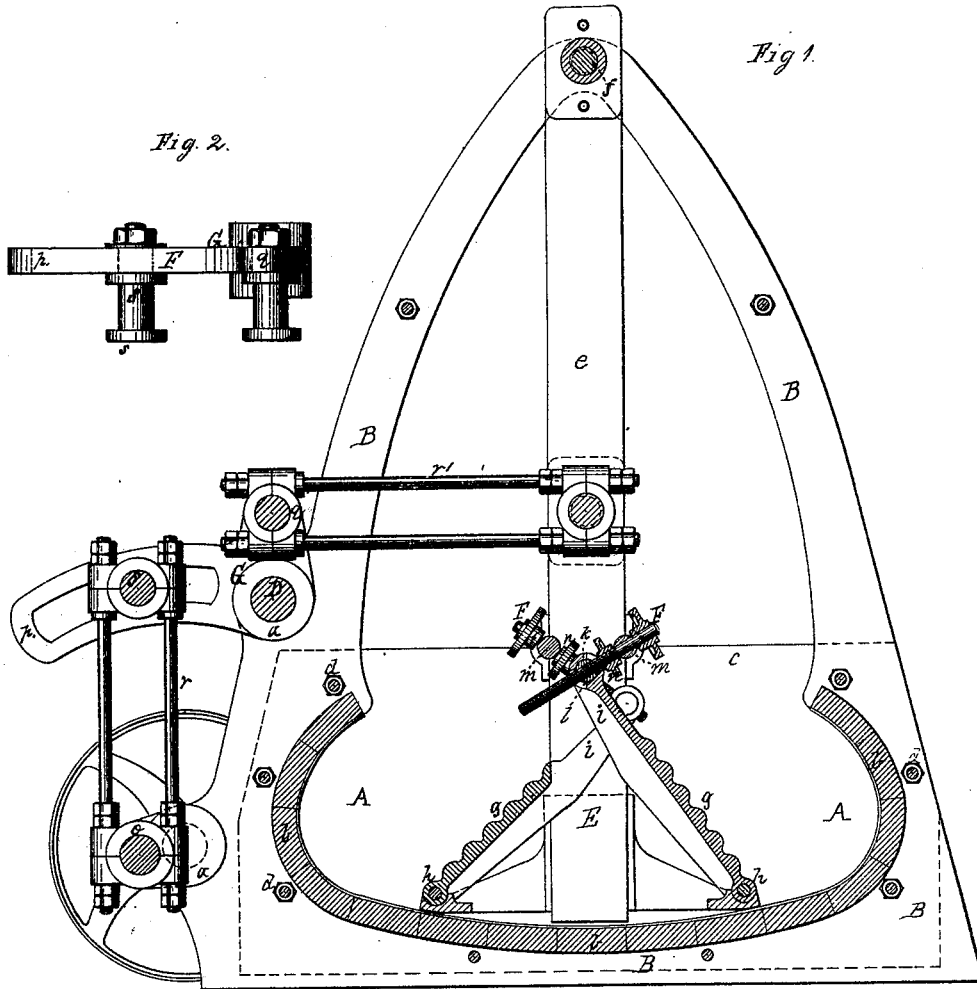

Fig. 2.

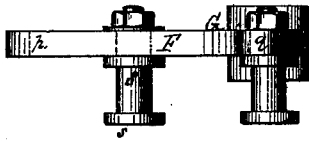
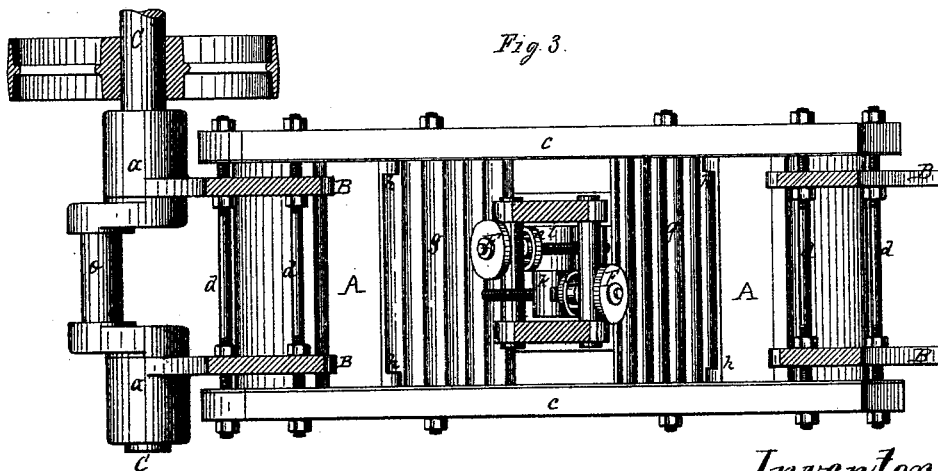

Fig. 3.



Witnesses:  
Philip S. Garner  
A. B. Canldwell.

Inventor:  
Rudolf Eickemeyer  
By *[Signature]*  
Attorney.

R. EICKEMEYER.  
FULLING-MILL.

No. 182,909.

Patented Oct. 3, 1876.

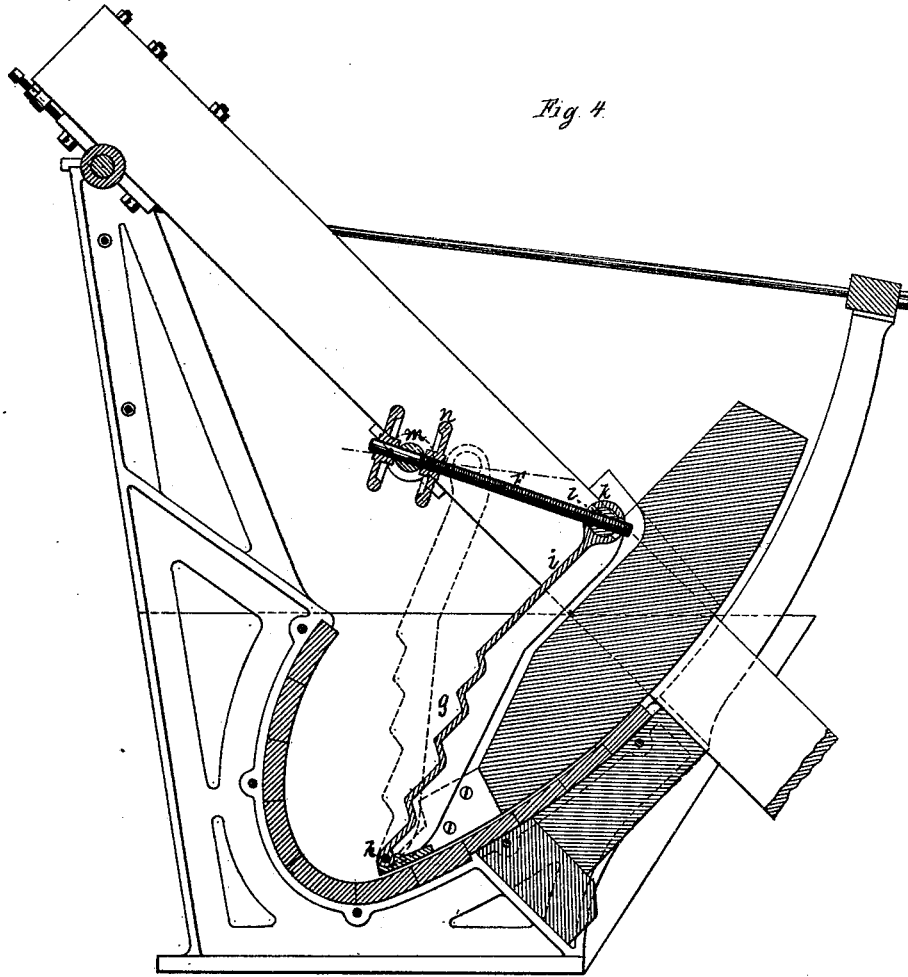

Fig. 4.

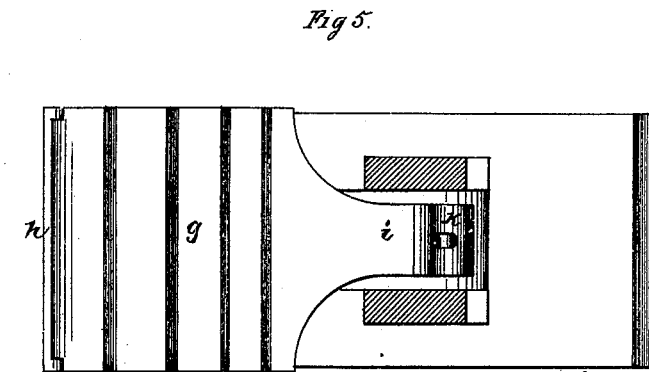

Fig. 5.

Witnesses:  
 Philip J. Garner  
 A. B. Caudwell

Inventor:  
 Rudolf Eickemeyer  
 By *[Signature]*  
 Attorney

# UNITED STATES PATENT OFFICE.

RUDOLF EICKEMEYER, OF YONKERS, NEW YORK.

## IMPROVEMENT IN FULLING-MILLS.

Specification forming part of Letters Patent No. **182,909**, dated October 3, 1876; application filed September 2, 1876.

*To all whom it may concern:*

Be it known that I, RUDOLF EICKEMEYER, of the city of Yonkers, county of Westchester, in the State of New York, have invented certain new and useful Improvements in Fulling-Mills; and I do hereby declare the following specification, taken in connection with the drawings furnished and forming part thereof, to be a full, clear, and correct description of my invention.

My improvements relate to those mills in which beaters or stocks are employed in contradistinction to the roller-machines.

Certain portions of my invention are applicable not only to falling beaters, but also to vibrating beaters, and other portions thereof are exclusively applicable to the vibrating beaters.

In operating upon hats or other woolen goods, it is desirable that the character of the blow from the beater upon the fabrics may be varied, and this I accomplish by having the face of the beater adjustable thereon, so that it may be set and operated at any desired angle; and one portion of my invention consists in a fulling-mill beater having a beating-face, which is adjustable at any desired angle, whereby one end of the face may be advanced or withdrawn at will, and secured in any desired position with relation to the main body of the beater.

Another portion of my invention consists in the combination, with a hinged beater-face, of a transverse cylindrical nut incased within a sleeve at the upper end of the face, and an adjusting-screw which engages with said nut, whereby the screw is free to operate regardless of the angular position of the beater-face.

Inasmuch as the force of the blow of the beater thus constructed is to a considerable extent borne by the adjusting-screw, it is essential that said screw should be firmly seated, and at the same time be capable of assuming varied angles in accordance with the angular position of the beater-face; and one portion of my invention consists in the combination, with an adjustable beater-face and its adjusting-screw, of a rocking seat for said screw, which is firmly secured to the helve of the beater.

It will be obvious that the several features

of my invention thus enumerated are applicable both to falling and to vibrating beaters.

Vibrating beaters, as heretofore constructed, so far as my knowledge extends, have been combined with their actuating mechanism in such a manner that their range of movement to and fro could not be varied. For certain classes of work the vibrating beaters are preferred.

The falling beaters have been heretofore variously arranged so as to have a variable fall, and to deliver graduated blows; but prior to my present invention vibrating beaters have had no such capacity, although said capacity in that class of machines is nearly, if not quite, as desirable as the same capacity is in the falling-beater mills. To this end, another feature of my invention consists in the combination, with a vibrating fulling-mill beater and its crank-shaft, of connecting-rods, a bell-crank lever, and an adjustable connecting device between one arm of the lever and one of the connecting-rods.

To more particularly describe my invention, I will refer to the accompanying drawings, of which there are two sheets.

Figure 1, Sheet 1, represents, in central longitudinal vertical section, a fulling-mill with vibrating beater, embodying all of my improvements. Fig. 2 represents, in top view, the bell-crank lever. Fig. 3 represents the fulling-mill in top view, with the frame-work, beater-helve, and connecting mechanism removed at a line near the top of the fulling-bed. Fig. 4, Sheet 2, represents, in central longitudinal vertical section, a fulling-mill with a falling beater, embodying a portion of my improvements. Fig. 5 represents the beater detached and in top view, with its helve removed.

Referring to the vibrating-beater mill illustrated on Sheet 1, the bed is shown at A. As usual, it is box-like in form, has a concave bottom, and upwardly and inwardly curved ends. It is also lined throughout with metal, so as to present a smooth and non-abrasive surface at all points. B denotes the frame of the machine, which supports the bed and the entire driving mechanism. It is composed of two counterpart castings, made from a pattern, to which parts may be attached, on either side

thereof, at one end, for forming bosses, as at *a*, for affording suitable bearings for the main shaft C and rock-shaft D. When these two plates are placed side by side they afford a foundation and support for the lags or sections *b*, of which the bottom and ends of the bed are composed, as shown in Fig. 1. These lags *b* extend on each side beyond the plates, and the sides of the bed *c* engage therewith, and are firmly secured by means of the rods *d*, which also pass through the side plates, as clearly shown in Figs. 1 and 2. A bed thus constructed can in no manner be strained or injured by the driving mechanism.

*E* denotes the vibrating beater, which is suspended by a helve, *e*, (in this instance in two parallel pieces,) supported on a rod, which has a bearing in both side plates B at *f*.

The beater is provided with two faces, as at *g*. They are both alike, and are provided, as usual, with a corrugated beating surface. Each is pivoted at its lower end to the beater, as at *h*, and at its upper end is provided with an arm, *i*, which terminates in a sleeve, *k*, which is parallel with the pivot *h*. This sleeve has peripheral slots opposite to each other for the passage of the adjusting-screw F, which is tapped into a cylindrical nut, *l*, contained within the sleeve *k*.

The adjusting-screw F is housed in a transverse shaft, *m*, which constitutes a rocking-seat for the screw, and has a journal-box at each of its ends firmly secured to the two parts of the helve *e*. A set-nut, *n*, on the adjusting-screw below the shaft *m*, enables the screw to be firmly set longitudinally in the shaft *m*.

Whenever it is desirable to change the angle of the beater-face, it is only necessary to turn the adjusting-screw in the required direction. The rocking capacity of the shaft *m*, and same capacity of the cylindrical nut *l* within the sleeve of the beater-face, permit the free adjustment of the beater-face, and the set-nut *n* firmly secures it in its adjusted position. The force of the blow is divided unequally between the lower end of the face and the shaft *m* which supports the adjusting-screw, but said shaft is amply strong to bear the strain to which it is in practice subjected.

In Figs. 4 and 5 the beater-face is slightly different in form, but it and the several parts require no specific description, as the letters of reference employed in these figures are the same as those of corresponding parts shown on Sheet 1, and the description already given is fully applicable thereto.

The main shaft C is as usual provided with a driving pulley, and power is communicated to the beater by means of a crank, as at *o*, which, by a connecting-rod, *r*, is attached to the long arm *p* of the bell-crank lever G, the

short arm thereof *q* being connected with the beater-helve by the rod *r'*.

The connecting-rods employed are of a well-known kind, composed of two rods, provided with nuts, between which the parts of the journal-boxes are secured, and they require no special description.

The bell-crank lever is mounted on the rock-shaft D, and has its long arm slotted. It is also preferably curved, as shown. An adjustable pin, *s*, is fitted to this slot, and by means of a washer and nut is readily set at any desired point within the slot.

The connecting-rod *r* attached to the crank is also attached to the pin *s*, and therefore to vary the throw of the beater the point of connection with the bell-crank lever will be varied with relation to the rock-shaft D.

I am well aware that in certain washing-machines, as heretofore constructed, vibrating rubbers have been so mounted on their operating levers that they could be adjusted angularly with relation to said levers. Such adjustment is, however, in washing-machines, provided solely with reference to a rubbing operation, and not to a beating operation, as in a fulling-mill.

I do not limit my invention to the precise mechanism herein shown, for approximately-valuable results in the adjustment of the beater-faces, and in the variation of the movements of the beater, may be readily attained by means of numerous other mechanical devices well known to persons skilled in the art, and obviously applicable in the same connection.

What I claim as new, and desire to secure by Letters Patent, is—

1. A fulling-mill beater, having an adjustable beater-face, substantially as described, whereby the face may be adjusted, set, and operated at any desired angle, as set forth.

2. The combination, with a fulling-mill beater, having a hinged or pivoted face, of an adjusting-screw attached to the beater-face by means of a sleeve and a cylindrical nut, substantially as described.

3. The combination, with a fulling-mill beater, of a hinged face and an adjusting-screw connected to said face, and housed in a rocking-seat secured to the helve of the beater, substantially as described.

4. The combination, with a vibrating fulling-mill beater and its driving-shaft, of connecting-rods, a bell-crank lever, and an adjustable connecting device between one arm of the lever and one of the connecting-rods, substantially as described.

RUDOLF EICKEMEYER.

Witnesses:

G. OSTERTRELD,  
GEORGE NARR.