

B. L. OSBORN & C. L. ALEXANDER.

THILL-COUPLING.

No. 182,952.

Patented Oct. 3, 1876.

*Fig. 1.*

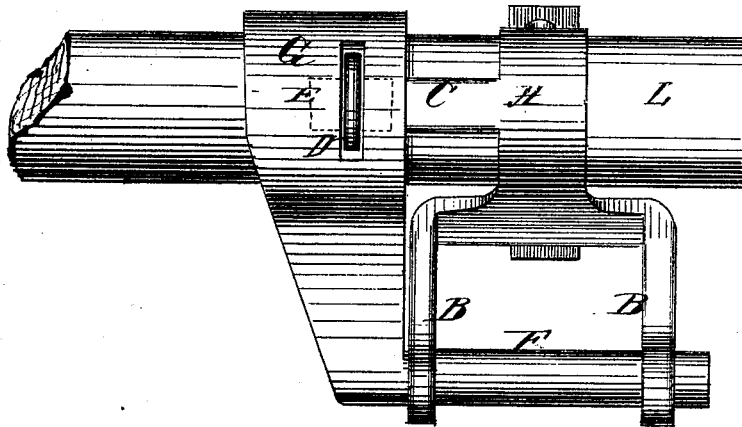

*Fig. 2.*

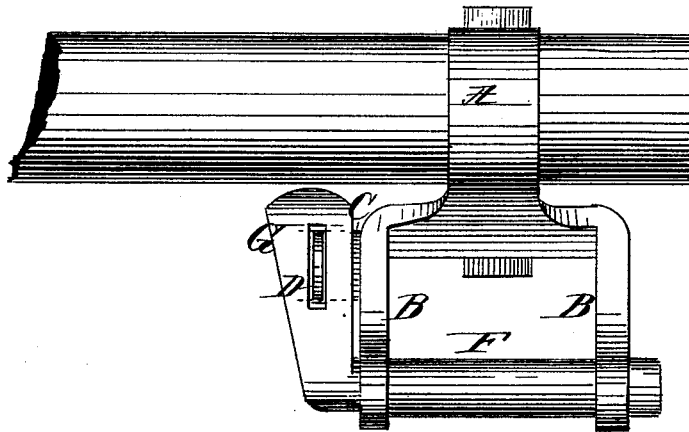

*Witnesses*  
*And C. Dietrich*  
*W. J. Hutchinson*

*Inventors.*  
*C. L. Alexander*  
*and B. L. Osborn.*  
*PER Daniel Breed*

*7224*

# UNITED STATES PATENT OFFICE.

BERESFORD L. OSBORN, AND CHARLES L. ALEXANDER, OF WASHINGTON,  
DISTRICT OF COLUMBIA.

## IMPROVEMENT IN THILL-COUPINGS.

Specification forming part of Letters Patent No. 182,952, dated October 3, 1876; application filed  
September 7, 1876.

*To all whom it may concern:*

Be it known that we, BERESFORD L. OSBORN, and CHARLES LOUIS ALEXANDER, of Washington, in the county of Washington, and District of Columbia, have invented certain new and useful Improvements in Thill-Couplings; and we do hereby declare that the following is a full, clear, and exact description thereof, which will enable others skilled in the art to which it appertains to make and use the same, reference being had to the accompanying drawings, and to the letters of reference marked thereon, which form a part of this specification.

Our invention consist of a novel construction of locking-bolt in combination with a clip, as an improvement in thill-couplings, which will be fully understood by the following description.

In the accompanying drawing, Figure 1 represents a top view of our improvement, the clip being shown in place upon a part of the axle of a buggy. Fig. 2 is a modified form of the same improvement.

The chief object of our improvement is to make a simple thill-coupling, which will allow the thills to be easily removed or exchanged for a pole, and also to make an improvement which can be conveniently applied to axle-clips now in use; and our invention consists of a bolt, provided with a slotted or locking hasp, in combination with a thill-coupling.

In the accompanying drawing, L represents a portion of a buggy or carriage axle, with

the clip A thereon. This clip, which embraces the axle, may be made in the ordinary manner, and the lugs B of the thill-coupling may be made without any screw-thread, and thus save expense. On the crown of the clip we make a projection, C, having a perforated ear, D, to receive the hasp of the bolt, which is locked in place by a leathern thong, E, (shown in dotted lines,) or by a suitable key. The bolt F is made smooth, or without any screw-thread, thus saving labor in the manufacture.

Instead of being made with the usual head, this bolt is forged with a slotted hasp, G, to hook upon the ear D of the clip, as above mentioned.

A modified form of the hasp G is shown in Fig. 2, and the projection C is connected with the lug B, both the slot in the hasp and the ear D being substantially the same as already described in Fig. 1.

Having thus described our invention, we claim—

In combination with the clip A and thill-coupling, having the ordinary lugs B, the ear D, bolt-hasps G, and key E, all constructed and arranged to operate in combination, substantially as and for the purposes set forth.

In testimony that we claim the foregoing as our own, we affix our signature in presence of two witnesses.

BERESFORD L. OSBORN.

CHAS. LOUIS ALEXANDER.

Witnesses:

DANIEL BREED,

J. C. WEAVER.