

W. F. CLARK.
VEHICLE SEAT.

No. 182,993.

Patented Oct. 10, 1876.

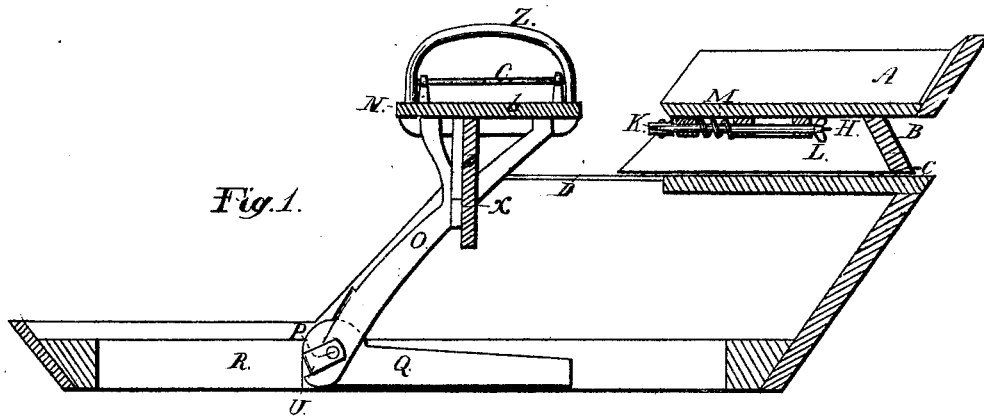

Fig. 1.

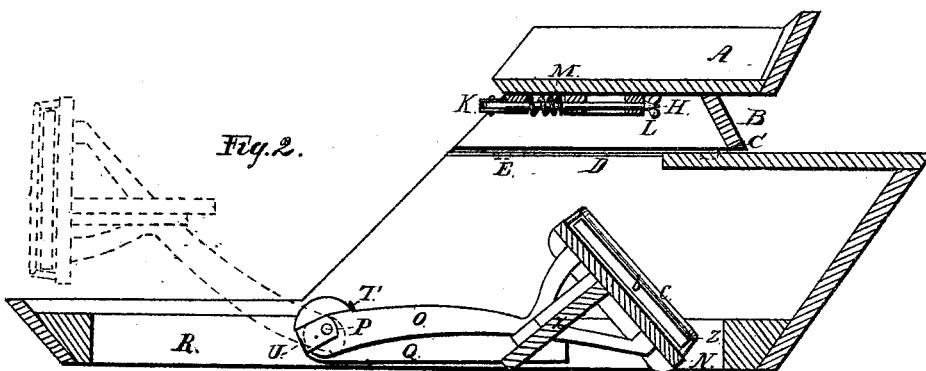

Fig. 2.

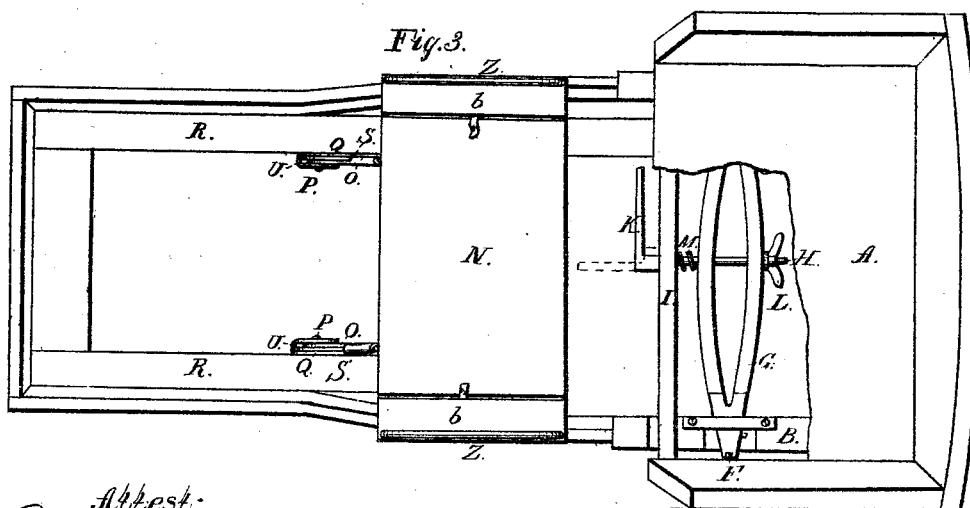

Fig. 3.

Attest:
E. M. Hollowell
J. O. Quincy

Inventor:
William F. Clark

W. F. CLARK.
VEHICLE SEAT.

No. 182,993.

Patented Oct. 10, 1876.

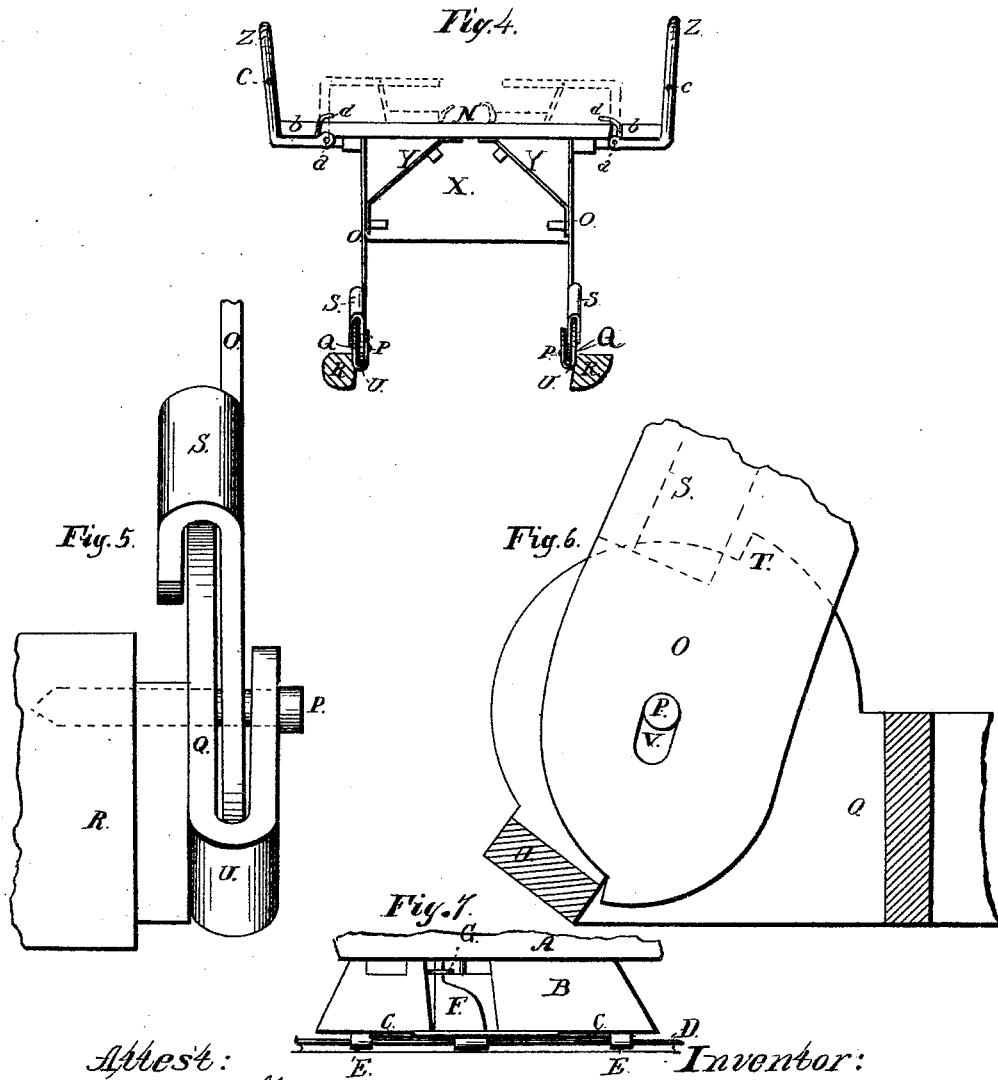

Attest:
E. M. Hallowell
J. C. Sumby

Inventor:
William F. Clark.

UNITED STATES PATENT OFFICE.

WILLIAM F. CLARK, OF ST. PAUL, MINNESOTA.

IMPROVEMENT IN VEHICLE-SEATS.

Specification forming part of Letters Patent No. 182,993, dated October 10, 1876; application filed March 7, 1876.

To all whom it may concern:

Be it known that I, WILLIAM F. CLARK, of St. Paul, in the county of Ramsey and State of Minnesota, have invented a new and useful Improvement in Slide and Jump Seat Buggy Bodies; and I do hereby declare that the following is a full, clear, and exact description thereof, which will enable others skilled in the art to make and use the same, reference being had to the accompanying drawings, forming part of this specification.

This invention relates to an improvement in slide and jump seat buggy bodies, such as are used for a pleasure buggy, with seats for two persons, and is convertible into a family carriage with seats for four persons; and it consists of a sliding back seat on ways, or rails on the top of the buggy-body, with a combination of clamping-levers and cross-bar to fasten it at any point.

This invention also consists in providing a front or jump seat with two legs, pivoted to a lock-plate, which is secured to the sill or bottom side of the body in such a way that when the seat is brought into position for use it falls into a lock, whereby it is held firmly in place, and is supported by the sill of the body, avoiding any short legs to rest on the top of the body.

This invention also consists in placing a board under the front seat, and securing it to the side braces in such a way that when the seat is swung forward the board serves as a child's seat.

This invention also consists in providing an extension on each end of the front seat, whereby, when the seat is brought into position for use, and the end guards turned out, the extensions rest upon the end guards and project beyond the sides of the body, giving as much room on the front as on the back seat, as will be hereinafter more fully described.

Figure 1 is a longitudinal sectional elevation of my improved buggy-body, when used as a four-passenger carriage. Fig. 2 is also a longitudinal sectional elevation of the body when used for two passengers, with the front seat swung back and the back seat brought forward over it; it also shows the front seat swung forward in position to be used as a child's seat. Fig. 3 is a ground plan of my

buggy as viewed from above, with the back seat cut away to show the action of the clamping-lever and cross-bar for fastening the seat to the rails of the body. Fig. 4 is a transverse section, showing the front seat in position, with the end guards turned out and the seat-extensions resting upon them. Fig. 5 is a horizontal section, showing the front seat with the end guards turned in and the extensions resting upon the main body of seat. Fig. 6 is a full size view of the lower end of the front seat-leg and the lock-plate upon which the leg is pivoted, and into which it locks. Fig. 7 shows a longitudinal section, showing the rails D and attachments.

Similar letters of reference indicate corresponding parts.

A represents the sliding back seat, mounted on risers B, which are provided with metal plates C, which slide on the rails D of the body. The riser-plates C are provided with hooks or clips E, extending either outside or inside of and under the edges of the rails D, serving as a guide for the riser B in its backward and forward movement on the rails D. The seat and riser are fastened to the rails D by clamping-levers F. The heel of the levers rest upon the top of the riser-plates C; the toe of the levers pass down through a mortise in the riser-plates C, and turns with a hook under the edges of the rails D. The top ends of the levers F are connected by the cross-bar G, which extends from side to side under the seat A. H is a bolt passing through the cross-bar G and the cross-bar I, and provided with a clamping-lever, K, at its forward end, and a regulating thumb-nut, L, at the other end. M is a spiral spring on the bolt H, between the cross-bars G and I. When the handle of the lever K is turned forward, as indicated by the dotted lines, the spring M carries the cross-bar G and the top ends of levers F backward, allowing the toe of the levers to drop below and clear of the rails D, when the seat can be moved forward and backward, as desired. When the handle of the lever K is turned back under the seat A, the cross-bar G, and top ends of levers F, are moved forward, causing the toe of the levers to engage the lower side of the rails D, and the heel of the levers to press down on the riser-plates C, clamping

them securely together. N is the front or jump seat. It is supported by the legs O, which swing on the pivots P in the lock-plates Q, which are secured to the sills R of the body. The legs O have stop-dogs S on the side, resting on the top of the lock-plates Q, and engaging notches T in the same. The lower points of the legs O engage with stop-dogs U on the sides of the lock-plates Q. The holes V, in the legs O, are elongated to twice the diameter of pivots P to allow of the seat being raised a little, when the stop-dogs S, and points of legs O, will disengage the notches T and stop-dogs U on the lock-plates Q, when the seat can be swung back within the sides of the body. When the seat is again brought up in position for use it falls into the lock above described, which holds it firmly from any backward swing without being first lifted up; but it is free to swing forward and rest on the front end of the body, to allow of easy access to and from the back seat A. X is a board, secured to the side braces Y of the seat N, and is used for a child's seat when the seat N is swung forward on the front end of the body. Z are end guards of the seat N, and are hinged at *a*. The seat-extensions *b* rest upon the end guards Z, as shown in Fig. 4, and are hinged on the rod *c* of the end guards. *d* are straps attached to the extensions *b*.

By lifting up the inner edge of the extensions with the thumbs and forefingers the end guards Z can be turned in with the remaining fingers, the extensions resting on the trimming of the main body of the seat N, when by placing one hand under the front edge of the seat, midway between the two ends, and lifting the seat out of its lock in plates Q, it can be swung back within the sides of the body.

When the seat N is again brought into position for use, and the end guards are turned out, the extensions are drawn after them, and fall of their own weight into the position designed for them, as shown in Fig. 4, making a seat as long as the back seat A.

The end guards Z and extensions *b* can be readily applied to seats with four legs; also, the lock formed by legs O and lock-plate Q can be applied to seats with four legs by arranging them on either the top or bottom ends of the hind legs, but preferably at the top end.

The advantages of this invention are the easy, quick, and secure arrangement for fast-

ening the back seat in any desired position, and also the easy operation of the front seat, and its self-locking arrangement and support on the sill of the body, avoiding any short legs resting on the top of the body; also, the extensions of the front seat over the sides of the body, giving more room and comfort to the occupants.

I do not claim as new the extension ends of the jump-seat, as I am aware that it is not new, as in the Patent of D. Ford, October 5, 1875, No. 168,386, the same device is shown; but my method of hanging the combined frame and end guard Z, and frame of the extension *b*, in such a manner that the extension may be lifted upward and folded over on the top of the main seat, I believe to be entirely novel. By the peculiar form of the frames the upholstering of the seats will lie flat on each other, and thus avoid the danger of forcing the hinges.

Having thus described my invention, I claim as new and desire to secure by Letters Patent—

1. The combination of the clamping-levers F and K, bolt H, thumb-nut L, spring M, and cross-bar G, with the back seat A, substantially as specified.

2. In carriages, sleighs, and similar vehicles, the legs O O, having the elongated pivot-holes V V, in combination with the stop-dogs U U, arranged and operating substantially in the manner and for the purpose hereinbefore set forth.

3. In carriages, sleighs, and similar vehicles, the combination and arrangement of the legs O O, stop-dogs S S, elongated pivot-holes V V, notches T T, and stop-dogs U U, arranged and operating substantially as hereinbefore specified.

4. The child's seat X, attached to the lower side of the seat F at right angles thereto, substantially as hereinbefore specified.

5. The angular-shaped frame Z, hinged to the frame of the seat N, in combination with the extension *b*, when the same is hinged to the frame Z, substantially as hereinbefore set forth.

WILLIAM F. CLARK.

Witnesses:

E. M. HALLOWELL,
J. O. QUINBY.