

J. SANGSTER & W. S. GROSVENOR.

MARINE ENGINE GOVERNOR.

No. 183,025.

Patented Oct. 10, 1876.

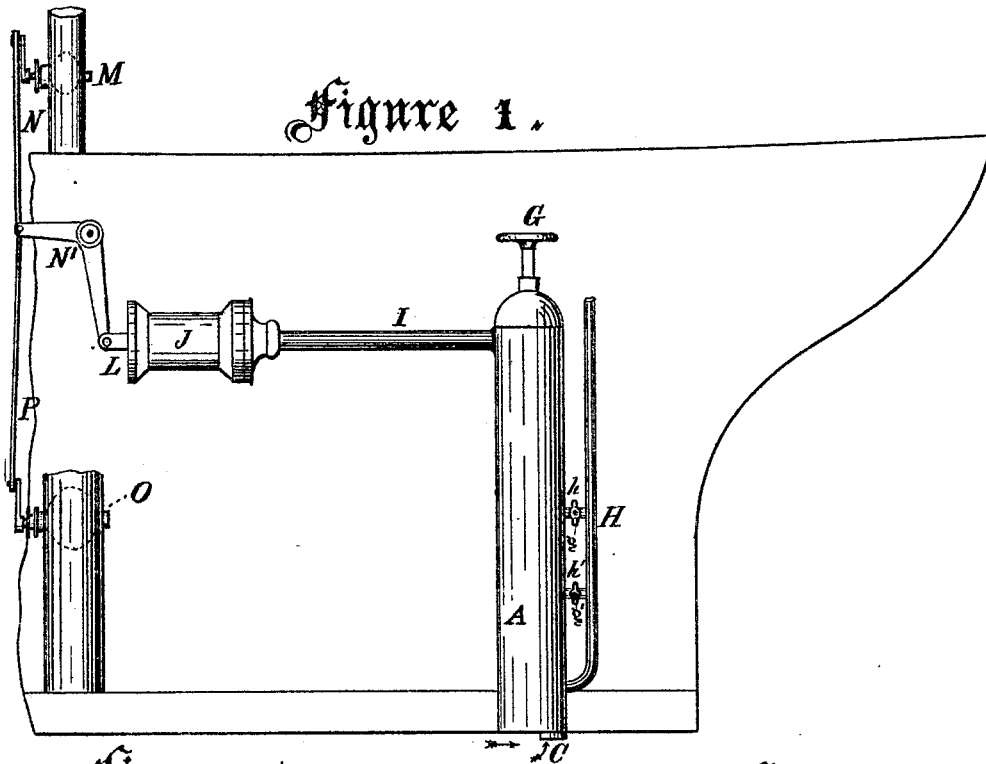

Figure 1.

Figure 2.

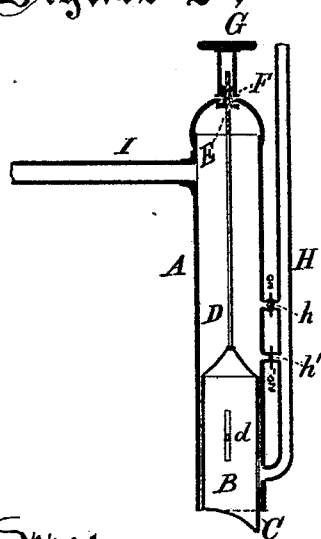
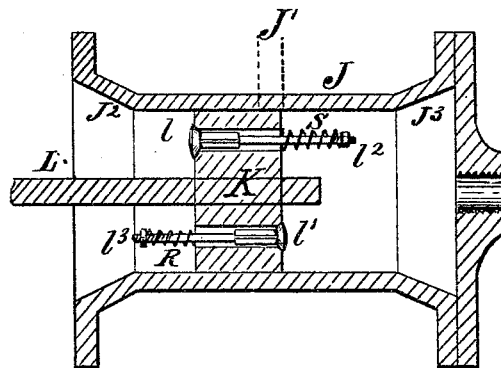

Figure 3.



Witnesses,
J. H. Wiley
Amos W. Sangster

Inventors,
 James Sangster
 William S. Grosvenor.
 By *James Sangster*
Atty.

UNITED STATES PATENT OFFICE.

JAMES SANGSTER AND WILLIAM S. GROSVENOR, OF BUFFALO, NEW YORK.

IMPROVEMENT IN MARINE-ENGINE GOVERNORS.

Specification forming part of Letters Patent No. 183,025, dated October 10, 1876; application filed August 24, 1876.

To all whom it may concern:

Be it known that we, JAMES SANGSTER and WILLIAM S. GROSVENOR, both of the city of Buffalo, in the county of Erie and State of New York, have invented certain new and useful Improvements in Marine-Engine Governors, which improvements are fully set forth in the following specification, reference being had to the accompanying drawings.

Our invention relates to that class of marine-engine governors having their action controlled by the motion of the vessel or water in a rough sea, for the purpose of preventing the racing of the wheel or propeller when raised more or less out of the sea by the pitching of the vessel.

The first part of our invention consists in the combination, with the air and water tube of a marine-engine governor, of an adjustable lip or plate arranged at or near the bottom of said tube, having a connection so that it can be conveniently adjusted up or down within the same for the purpose of regulating the height of the water within said tube according to the speed of the vessel, as will be more clearly hereinafter shown and described.

The second part of our invention consists in a marine-engine governor, of an air and water tube, a piston and relief valves, the water-tube being arranged as near the stern as possible, having an outlet at the bottom, and having the air-tube connected to it at some point above the water-level and leading from thence to some point convenient to the engine, in combination with an outlet and inlet relief-valve, a cylinder and piston, a steam-controlling valve, and a vacuum-controlling valve, for controlling the vacuum or shutting off communication with the condenser.

The third part of our invention consists in the combination in a marine-engine governor of an additional air and water tube connected near the said bottom of tube, so as to project upward alongside of it, and having a series of communications arranged one above the other, controlled by stop-cocks, for the purpose of regulating the point at which it is desired the governor shall act, as will be more clearly hereinafter shown.

In said drawings, Figure 1 represents a side elevation of our invention complete; Fig. 2, a vertical longitudinal section through the wa-

ter and air tubes; and Fig. 3 represents an enlarged section through the cylinder and relief-valve.

A represents the water-tube; B, a tube or plate arranged within it, so as to be moved up or down. The bottom part of B is made to project downward farther on one side than the other at C. D is a rod connected to the upper part of B, and provided with a screw, E, at the upper end. B is prevented from turning by a pin or slot, as shown at *d*. The screw E passes into a nut, F, which is fastened to A, as shown, so as to be held securely thereto and turn easily. It will be seen that by turning G the tube B may be raised or lowered to any degree desired. The object of this part of our invention is to provide the means for regulating the height of the part C. The movement of the boat through the water, and the consequent friction of the same in passing the bottom end of the tube A will lower the level of the water therein in a certain proportion to the speed of the vessel, sufficiently so to interfere with the action of the governor. The part C may be made as shown, or in the form of a flat plate, as required. H represents an auxiliary tube connected with A near the bottom. *h h'* represent pipes connecting A and H, communication between the two being controlled by means of stop-cocks *g g'*. There may be more or less pipes *h h'* if required. The object of this part of our invention is to provide the means for regulating the point in the immersion of the vessel at which the governor shall act. It will be seen that if stop-cock *g'* be opened and *g* closed the water as it rises in A will not begin to compress the air above it until it passes the opening *h'*, as the air has free exit through it, and that if *g* be opened and *g'* closed it will not begin to compress the air, and consequently operate the governor, until it has passed *h*. I represents the air-tube, and J the cylinder; K, the piston, which is made and packed so as to move with the least possible friction. L represents the piston-rod. *l l'* are two relief-valves, one for operating when there is pressure within the air tube or space, and one when a partial vacuum is formed therein. The object of this part of our invention is to equalize the pressure of air within the air tube and space, as the variations in the speed

of the vessel, and in the direction of the currents of the water through which the vessel is passing, or the commotion of the sea in a storm, will continually change the level of the water in the tube A, thereby changing the tension of the air within. When the level of the water in said tube is lower, the inlet-valve *l* will admit more air; when higher, the outlet-valve *l* will allow the air to pass out. Were it not for the relief-valves air enough would sometimes work its way through the water in a heavy storm into the air tube and space to prevent a sufficient vacuum being formed therein to properly operate the governor when the propeller raises out of the water. The relief-valves may be adjusted so as to be held with more or less force to their seats by means of adjusting-nuts or thumb-screws *l* *l'* being forced more or less against the springs R S.

In Fig. 1, M represents a valve connected with a pipe leading from a low-pressure cylinder to the condenser, which is connected with the governor by means of arms N N'. O represents a valve for controlling the amount of steam admitted to the engine. This valve is also connected to the governor by means of the arms P and N'. We have shown an ordinary butterfly-valve; but any ordinary valve suitable for the purpose will answer.

It will be understood that the arrangement shown in the drawing is adopted merely for conveniently exhibiting the invention. The relative position of the tubes A I and governor, with reference to the position of the engine, may be changed according to circumstances, so as to adapt it to the vessel.

An equivalent for the inlet and outlet relief-valves would be to put an opening through

the side of the cylinder, (shown by dotted lines J¹.) and arrange the piston so that each side of it would pass by it at the end of its stroke each way, thereby relieving the pipes of any undue pressure of air; but this arrangement would not answer the purpose so well. The same result can be accomplished by tapering the opening at each end of the cylinder, as shown at J² J³, and allowing the piston to pass a little beyond it at the end of each stroke.

We claim as our invention—

1. In a marine-engine governor, the combination of the air and water tube A I, the adjustable lip or plate C, and piston K, substantially as and for the purposes specified.

2. The combination, in a marine-engine governor acting on the steam-controlling valve, of an air and water tube, A I, a cylinder and piston, and inlet and outlet relief-valves *l* *l'* arranged in said piston, substantially as and for the purposes specified.

3. The combination, in a marine-engine governor, of a supplementary air and water tube, H, with the main tube A and one or more pipes, *h* *h'*, having stop cocks or valves for controlling communication between them, for purposes substantially as described.

JAMES SANGSTER.

WM. S. GROSVENOR.

Witnesses to the signature of JAMES SANGSTER:

AMOS W. SANGSTER,

F. P. STIKER.

Witnesses to the signature of WILLIAM S. GROSVENOR:

JONA. AUSTIN,

EMORY CUMMINGS.