

G. LEACH.
GRAIN-SEPARATOR.

No. 183,059.

Patented Oct. 10, 1876.

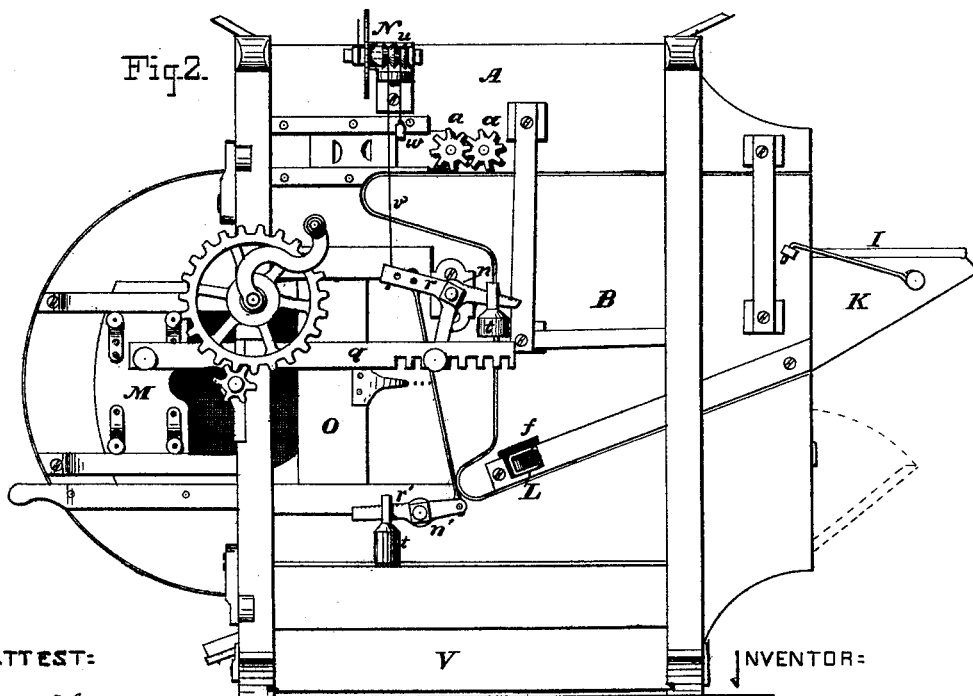
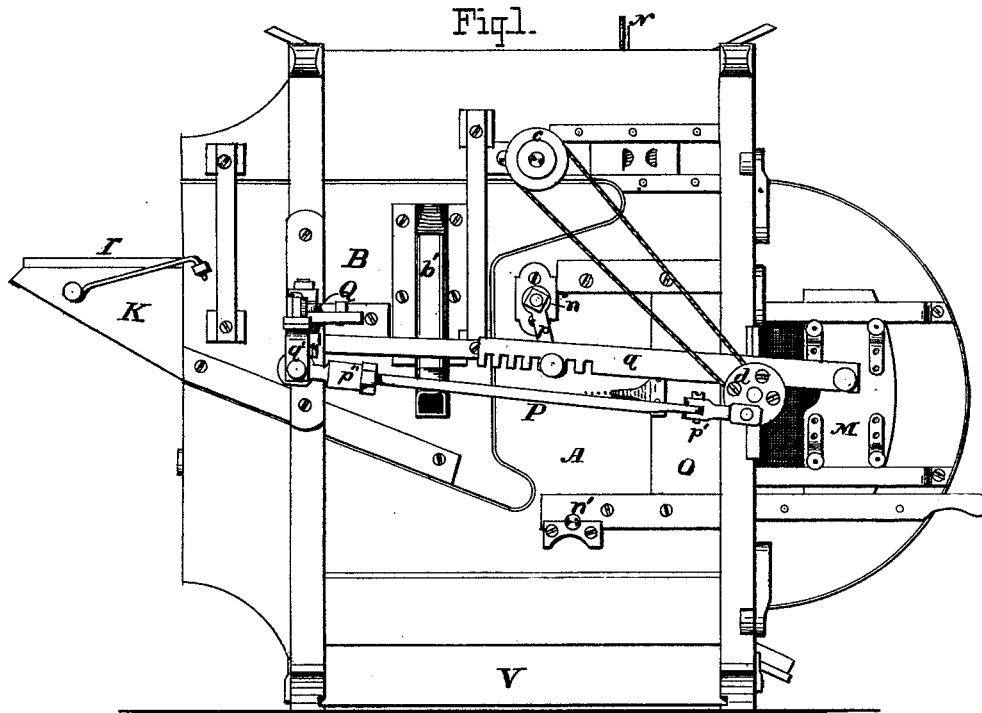

ATTEST:

Arthur C. DeWitt
Arthur C. DeWitt.

INVENTOR:

George Leach
Per *Burke & Fraser*
Atty's.

G. LEACH.
GRAIN-SEPARATOR.

No. 183,059.

Patented Oct. 10, 1876.

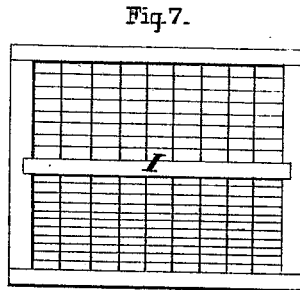
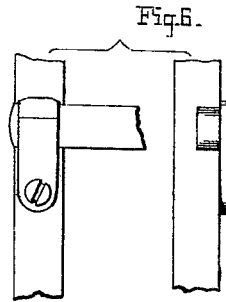
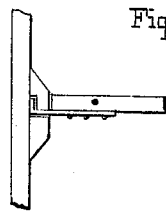
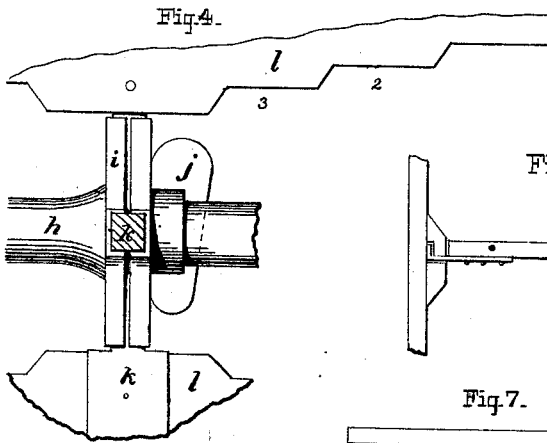
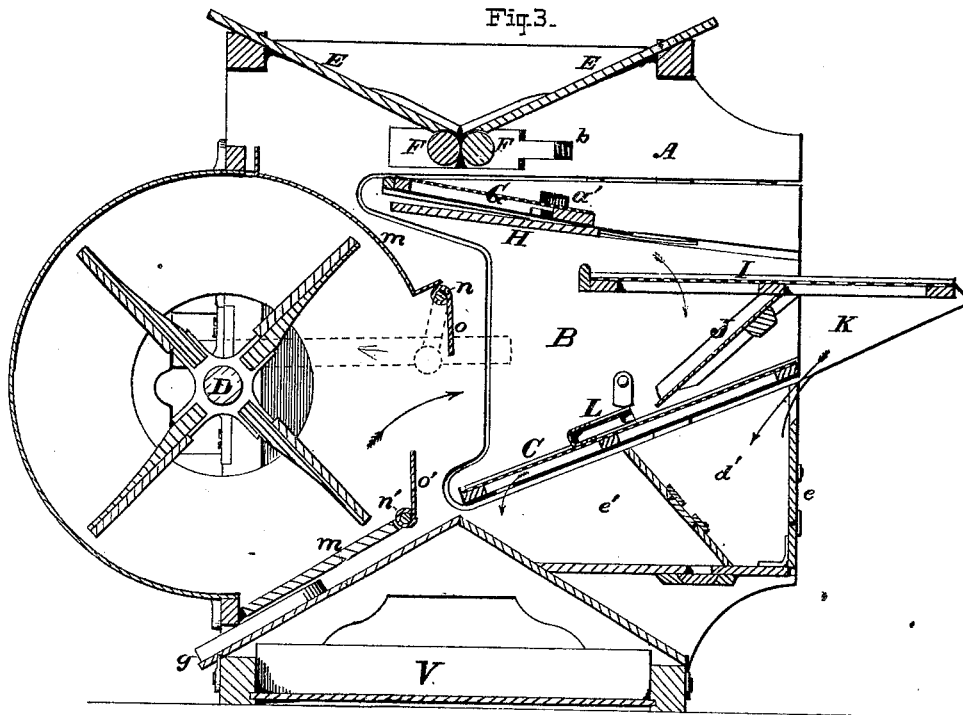

ATTEST:
Arthur C. Fraser
 Arthur C. Fraser.

INVENTOR:
 George Leach
 Per Burke & Fraser
Atty

G. LEACH.
GRAIN-SEPARATOR.

No. 183,059.

Patented Oct. 10, 1876.

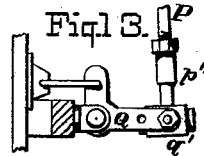
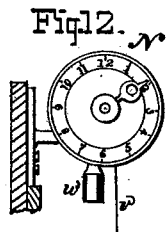
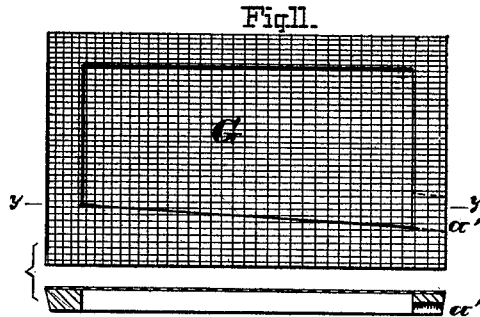
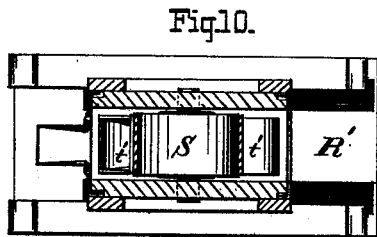
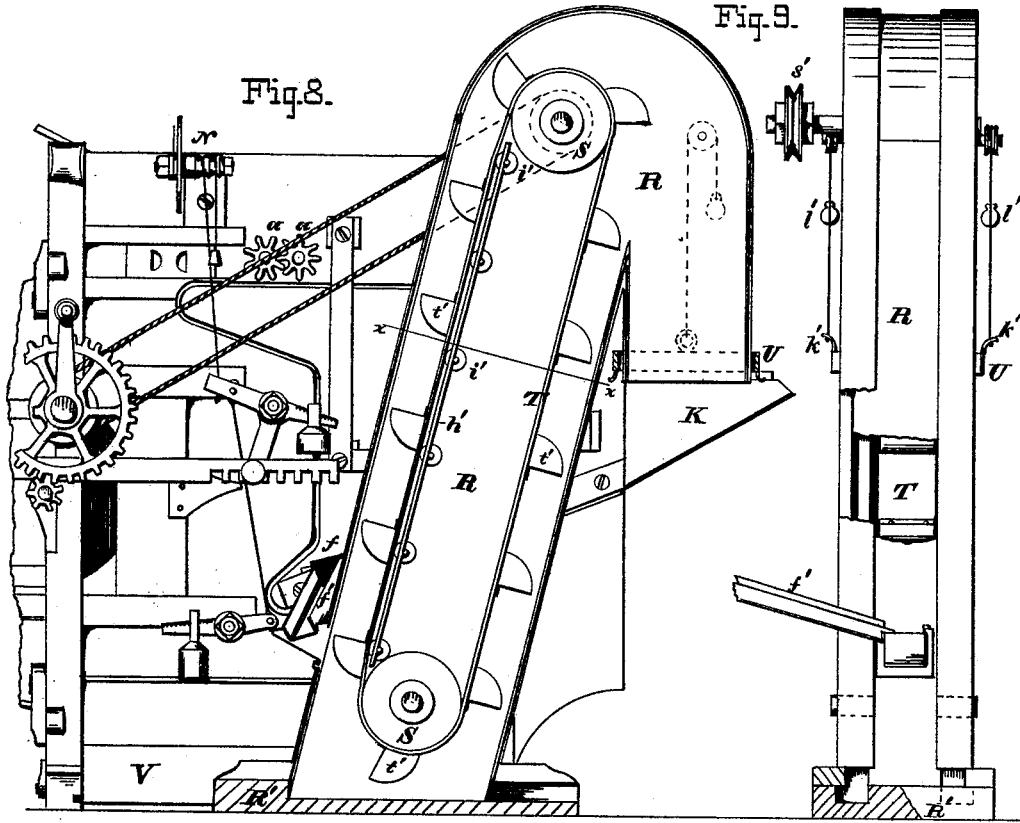

ATTEST:

Wm. H. DeBevoise
Arthur C. Fraser

INVENTOR:

George Leach
Per Burke & Fraser
Atty

UNITED STATES PATENT OFFICE.

GEORGE LEACH, OF SCHENECTADY, NEW YORK, ASSIGNOR TO HIMSELF
AND JOHN D. CAMPBELL, OF SAME PLACE.

IMPROVEMENT IN GRAIN-SEPARATORS.

Specification forming part of Letters Patent No. **183,059**, dated October 10, 1876; application filed
April 22, 1876.

To all whom it may concern:

Be it known that I, GEORGE LEACH, of Schenectady, in the county of Schenectady and State of New York, have invented certain Improvements in Machines for Separating, Cleaning, and Bagging Grain Seeds, &c., of which the following is a specification:

The object of the machine embodying this invention is to take grain, seed, &c., that is intermixed with each other and with straw, chaff, and other foreign matter, separate, clean, and deliver it, as a final result of the operation, into bags or other receptacles.

The invention consists, mainly, in improvements on the ordinary fanning-mill and elevating mechanism as a basis, and each novel feature will be particularly described hereinafter.

In the drawings, Figure 1 is a side elevation, the right-hand side of my improved machine with the bagging mechanism omitted. Fig. 2 is an elevation of the opposite side. Fig. 3 is a longitudinal vertical midsection of the same. Fig. 4 is a detail view of the fan enlarged. Fig. 5 is a sectional view enlarged, showing the "lock-groove" joint, by means of which certain parts are secured. Fig. 6 is a detail view enlarged, showing the fastening by buttons. Fig. 7 shows the double sieve. Fig. 8 is a view of the elevating and bagging mechanism, with the side plate removed to show the interior. Fig. 9 is a rear view of the same, partly broken away to show the construction. Fig. 10 is a cross-section taken in the plane of the line *xx* in Fig. 8. Fig. 11 shows the seed-screen in plan and section. Fig. 12 is a detached front view of the indicator. Fig. 13 is a detached plan view of the bell-crank and connecting-rod for agitating the shoe.

Like letters of reference designate corresponding parts in all of the figures.

The general form and arrangement of parts are similar to that in the ordinary machines of this class, A being the casing or frame; B, the shoe; C, the lower screen, and D the fan, the latter being operated by a crank, and gears in the usual way. E E are boards, which form the hopper, arranged to slide in grooves

and capable of being readily removed. F F are feed-rollers, mounted in bearings in the casings and extending across the hopper. They are provided with intermeshing toothed wheels *a a*, mounted on the prolongations of their journals. One of these rollers is held up to its companion by means of springs *b b* acting against sliding boxing, and the other bears a cone-pulley, *c*, connected by a belt, with a corresponding cone, *d*, on the fan-shaft, from which the rollers derive motion. The cone-pulleys serve to regulate the speed of the feed-rollers, and they, in turn, regulate the delivery of the grain to the separating and fanning mechanism, and serve to evenly distribute it.

Immediately below the feed-rollers, and resting upon the feed-plate, is a seed-screen, G, shown in detail in Fig. 11. This consists of a shallow pan, with a gauze cover, the meshes of which are too fine to pass grain, but readily pass small seed. These are guided down the incline formed by the side strip and pass out at an opening, *a'*, in the side, which corresponds with a down-spout, *b'*, attached to the shoe. By this means the fine seed is separated and carried off without coming in contact with the blast.

From the seed-screen the grain passes to the seed-rake H, Fig. 3, which is constructed similarly to that in ordinary use, but arranged to slide out and in, in grooves, so that it can be adjusted to the desired degree of separation—that is, when drawn out, much more grain passes over as light grain than when pushed back. In the drawing it is shown pushed back to its fullest extent. The advantages of this adjustability will be more fully understood from the description to follow:

At I is shown my improved double sieve, clearly illustrated also in Fig. 7. One-half of this sieve is constructed with a coarser mesh than the other, and either end may be inserted to suit the grain being cleaned.

Below the sieve is arranged a sliding shutter, J, provided with and attached by a lock-groove joint, as shown in Fig. 5. This shutter extends from the central bar of the double

sieve down to, or nearly to, the screen C, and effectually cuts off the blast from the outer half of the sieve, thus permitting the light grain, which is driven by the blast beyond the center of the sieve, to fall into the removable extension K, from whence it finds its way eventually to the light-grain box *d'*, as indicated. This box is provided with a hinged door, *e*. The screenings pass through the screen C, and thence through an opening in the sheet-iron bottom of the shoe to the box *e'*, as indicated. This box is provided with a suitable slide-covered aperture, as shown, in the bottom, and a small door is provided in the partition between the boxes.

If the grain is to be bagged, an inclined spout, L, is placed laterally across the screen C to catch and convey the grain out at a side aperture, *f*, to the bagging mechanism, as shown in Fig. 8, but which will be more fully described farther on. If it is not desired to bag the grain at once, it is allowed to pass out at the aperture *g*, at the front of the machine.

The fan possesses some novel features, which I will now describe, referring especially to Fig. 4 for illustration.

Let *h* represent the fan-shaft, provided with a shoulder against which abut two half-sockets, *i i*, arranged to be held forcibly together by means of a key, *j*. In these sockets are firmly held the arms *k k* of the fan, to which are attached the blades *l l* of the fan, parts only of which are shown in the figure. These blades are peculiarly shaped, by being cut away in a series of offsets or steps, 1, 2, and 3, the direction of the cut being parallel with the axis of the fan-shaft *h*. The ends of the fan-blades should be cut away so as to clear the openings around the fan-shaft to admit the air, and then be graduated in steps toward the middle, as shown, the essential feature being the parallelism of the cut with the axis of the fan-shaft, as before stated. This construction admits the air more freely, and in greater volume, than that ordinarily used; and the method of fastening the arms as above described enables the blades to be readily removed for repair or transportation.

I will now describe the device for regulating the blast to the kind of grain or seed to be operated upon. Forming part of the fan-housings, above and below, are two slides, *m m*, which deflect and confine the blasts to the proper direction. At or near the inner edges of these slides are mounted two cross-shafts, *n n'*, which have bearings in the casing A. On these are rigidly fixed blades or vanes *o o'*, which I denominate air valves. In their normal condition these valves rest in a vertical position, as shown in Fig. 3, and tend to intercept the current of air from the fan. It is also obvious that the action of the blast upon them would tend to rotate their respective shafts in opposite directions with equal force.

On the outer ends of the upper shaft *n*, which project beyond the casing A, are crank-arms *p p*, having wrists which engage

draw-bars or connecting-rods *q q*. These latter extend forward and engage wrists on the sliding shutters M M, arranged to close the air-apertures in the ends of the fan-casing. The bars *q q* are notched where they engage the wrists, so that the said bars may be adjusted as to length, and the shutters M M set at any desired point at starting. In addition to the arms *p p*, the shaft *n* bears at the same point cross-branches *r r*, at right angles to the said arms. On the lower shaft *n'* is secured a like cross-bar, *r'*, but only one end of the shaft is so provided. To one branch of the latter bar a connecting-rod, *s*, is pivoted, which extends upward and takes hold of the opposite branch of the cross-bar *r*. On the other branches are hung adjustable weights *t t*, as shown.

When the blast acts upon the air-valves *o o'*, the partial rotation of the shafts *n n'*, acting through the rods *q q*, tends to close the shutters M M and diminish the freedom of access of air to the fan. In other words, the device acts as an automatic governor.

To properly make known the action of the governor to the operator or attendant, an indicator-dial, N, is mounted on the casing and provided with a double-grooved sheave, *u*. A cord, *v*, attached to the arm *r*, is passed around and secured to the sheave, and another cord, rove around the sheave in the other direction, sustains a weight or counter-balance, *w*. The oscillation of the shafts *n n'* produces oscillation of the hand in front of the dial. By keeping his eye on the dial, and regulating his motions thereby, the operator may maintain the hand at any desired point, and thus preserve perfect uniformity in the blast. By moving the weights *t t* out or in on their respective branches, the sensitiveness of the governor may be controlled. For heavy grain, requiring a strong blast, they are moved out; for light grain or seeds, they are moved in. One valve, *o* or *o'*, alone would serve the purpose, perhaps, but this would deflect the blast out of its true course. When two are used, arranged above and below, as shown, the blast is uniformly directed in the proper course.

O O are auxiliary sliding shutters of the usual kind, arranged to be regulated by hand.

In place of the sliding shutters M M, "register-valves" or slats turning on pivots may be used.

The shoe B is suspended in the usual manner, and the lower front extremity or toe is prolonged, to form a housing for the lower end of the screen C, as shown. It is agitated by a bell-crank and connecting-rod of novel construction, which I will now describe.

The rod P is jointed laterally at *p'*, and provided with a longitudinal adjustment at *p''*. To the bell-crank Q (see Figs. 1 and 13) is attached a swivel, *q'*, the pendent jaws of which embrace the end of the connecting-rod P. This construction permits the proper fitting of all of the joints and, at the same time, allows for all lateral play.

The elevating and bagging mechanism will be understood by reference to Figs. 8, 9, and 10.

R is an elevator-case, constructed so that all of the major parts are readily separable, being put together by the lock-groove joint. (Shown in Fig. 5.) R' is the base. S S are the elevator-pulleys, the upper one of which is provided with a driving-sheave, *s'*, on its prolonged journal geared by a belt with a corresponding sheave on the fan-shaft, as shown. T is the elevator-belt, and *t' t'* the cups. To reduce the friction in the upward travel of the belt on the loaded side, I provide a bearing-plate, *h'*, in which are mounted friction-rollers *u' u'*. The belt rides upon these in going up, and the friction is materially reduced. At the back of the elevator is an inlet for the grain from the mill, which is conveyed by means of a spout, *f'*.

The discharge-nozzle of the elevator is surrounded by a loose band, U, (shown in section in Fig. 8,) provided with hooks at intervals to support the bag, and loops *k' k'*, to which are attached cords that pass over pulleys or sheaves and support weights *v' v'*, to counterbalance the weight of the bag, and keep it properly suspended.

V is a drawer, which slides in grooves in the frame beneath the mill, and is designed to hold the extra sieves and seed-screens.

The operations of cleaning, separating, and bagging are carried on simultaneously.

One very important feature of my machine is its portability, which arises from the novel construction and method of putting together by what I denominate "lock-groove" joints and by buttons, as illustrated in the Figs. 5 and 6. This joint is made by forming an L-shaped groove in one piece, or in cleats attached to the piece, and forming an L on the attached piece to fit the said groove. The bottom plate of the shoe, the slide J, and the entire casing of the elevator are provided with these joints, and the base of the elevator is attached in a like manner. When the parts are provided with these joints they may be readily put together and taken apart, and when together they make a firm and solid structure.

The cylindrical fan-casing, the pitched bottom boards of the machine, and all of the cast bearings and provisions about the machine are held in place by buttons, substantially as shown in Fig. 6 and the several drawings. The hopper-boards E E, the rake H, screen C, sieve I, casings *m m*, and the bottoms and walls of the boxes *d' e'* rest in grooves in the main casing A, and are readily removed.

The object and advantages of this method of construction are that the whole, including the fan and bagging mechanism, can be taken to pieces and packed or boxed in a small compass, and thus avoid damage and expense

in transportation. It also enables the owner to readily replace any broken part without removing extraneous fastenings.

The extension K is simply put in place and secured by hooks, as shown in the several figures.

Having thus described my invention, I claim—

1. In a fanning-mill, the combination of the feed-rollers F F, the cone-pulleys *c* and *d*, and the fan D, all arranged in such manner that the speed of the rollers will be proportioned to the speed of the fan, and the number of revolutions of the rollers relatively to that of the fan be capable of adjustment, as herein set forth.

2. The slide forming the bottom of the shoe B, provided with a lock-groove joint, as shown in Fig. 5, by means of which it is secured in place, as set forth.

3. In a separator, the combination of the sieve I, having a central partition and gauze of two degrees of fineness of mesh, the screen C, and the slide J, arranged beneath the sieve I, with its upper edge in loose connection with the central partition of same, as and for the purposes set forth.

4. In a separator, the combination of the extension K, the sieve I, with central partition and gauze of two degrees of fineness, the slide J, arranged directly beneath said partition, and box *d'*, all arranged and constructed as set forth.

5. The combination of the shouldered shaft *h*, halved sockets *i i*, key *j*, arms *k k*, and fan-blades *l l*, substantially as set forth.

6. The combination of the shutters M M, or their equivalents, rods or bars *q q*, valves *o o'*, arms *p p*, branches *r r'*, rod *s*, and weights *t t*, constructed and arranged to operate substantially as set forth.

7. The elevator-case R, having its four walls formed with lock-groove joints, as shown in Fig. 5, whereby they are held firmly together, but capable of being readily taken apart for packing, as herein set forth.

8. In combination with the air-valves *o o'*, arranged in the interior so as to be operated by the fan-blast, the indicator N, branches *r r'*, rod *s*, cord *v*, and weights *t t w*, or their equivalents, to form an indicating device to govern the speed of the fan, as set forth.

9. The connecting-rod P, having a lateral joint at *p'*, and longitudinal adjustment at *p''*, in combination with the bell-crank Q, swivel *q'*, fan D, and shoe B, all as herein set forth.

In witness whereof I have hereunto signed my name in the presence of two subscribing witnesses.

GEORGE LEACH.

Witnesses:

JOHN B. CLUTE,
C. E. KINGSBURY.