

W. JENKINS.

HAT BOX-BOARD CUTTING-MACHINE.

No. 183,172.

Patented Oct. 10, 1876.

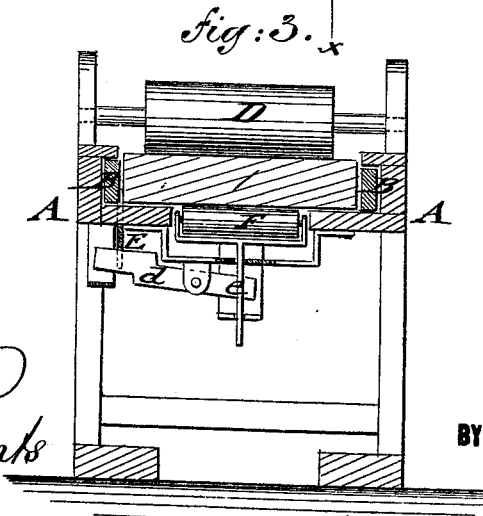
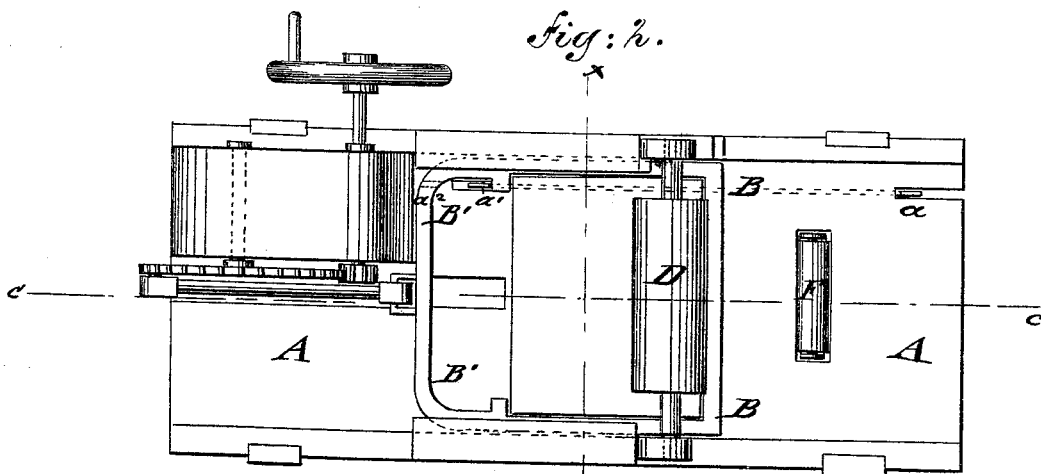
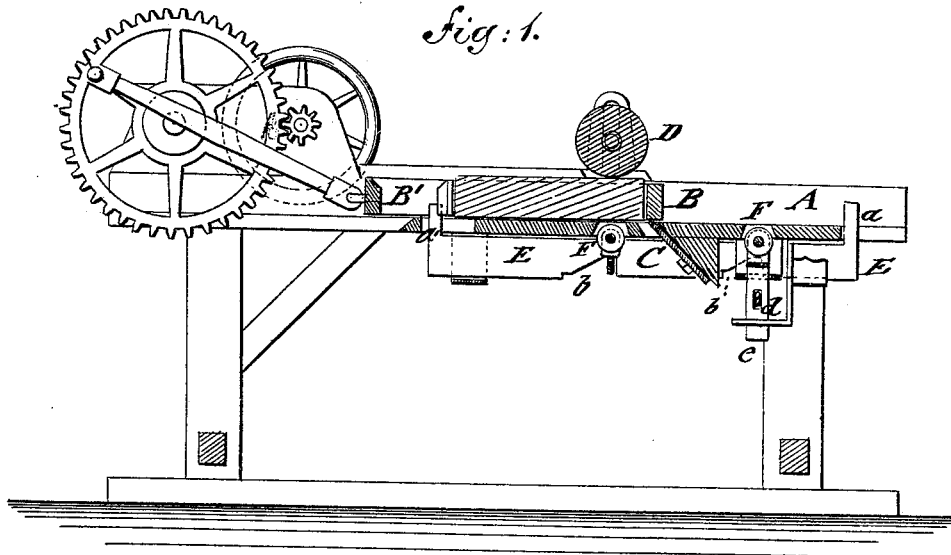

WITNESSES:

*Chas. Nida*  
*Alex. F. Roberts*

INVENTOR:

*Wm. Jenkins*

BY

*Muntz*

ATTORNEYS.

# UNITED STATES PATENT OFFICE

WILLIAM JENKINS, OF NEWARK, NEW JERSEY.

## IMPROVEMENT IN HAT-BOX-BOARD-CUTTING MACHINES.

Specification forming part of Letters Patent No. 183,172, dated October 10, 1876; application filed August 5, 1876.

*To all whom it may concern:*

Be it known that I, WILLIAM JENKINS, of Newark, in the county of Essex and State of New Jersey, have invented a new and Improved Hat-Box-Board-Cutting Machine, of which the following is a specification:

In the accompanying drawing, Figure 1 represents a vertical longitudinal section on line *c c*, Fig. 2, of my improved hat-box-board-cutting machine; Fig. 2, a top view, and Fig. 3 a vertical transverse section of the same on line *x x*, Fig. 2.

Similar letters of reference indicate corresponding parts.

My invention relates to improvements in machines for cutting thin boards to be used in the manufacture of hat and other boxes in place of pasteboard, so that the same is worked with great rapidity and facility, and the block raised and passed over the knife during the return stroke without touching and dulling the same.

The invention consists of a reciprocating carrier that feeds the block against the adjustable cutting-knife to cut off the thin boards.

The board is pressed in one direction against the knife by a weighted roller, and lifted by vertically-movable rollers and actuating mechanism operated by the carrier when sliding in opposite directions to clear the knife.

In the drawing, A represents a bench of the usual construction, that guides in suitable ways the box-shaped carrier B, which is reciprocated by a crank-shaft and suitable gearing by hand or other power.

The block of wood from which the thin boards for making hat-boxes, &c., are cut is placed into the carrier and fed by the same against an inclined cutting-knife, C, that is secured in adjustable manner in a throat of bench A, so as to cut boards of greater or less thickness, as required. A weighted roller, D, bears on the top of the block and moves vertically up and down in slotted guide-standards of the bench. The pressure of the roller secures the uniform and reliable cutting of a thin board at each forward motion of the carrier. The carrier B is constructed at the side to which the crank-rod is applied with an extension, B', into which the weighted roller drops when the carrier arrives at the end of the forward stroke. Simultaneously therewith the carrier engages the projecting end *a*

of a longitudinal slide-rod, E, which bears by inclined recesses *b* on lateral fulcrumed levers *d*, which are set into slotted and guided stems *e* of vertically-sliding rollers F. The rollers F are placed near the cutting-knife, one at each side of the same, and raised by the sliding rod E, so as to lift the block above the knife during the return stroke, and admit the passage without forming contact therewith. When the carrier is at the end of the return stroke it engages the projecting opposite end *a*<sup>1</sup> of the slide-rod E, carrying the same back, so as to release the roller-actuating levers, and throw thereby the rollers below the level of the bench.

The extension-frame B' of the carrier is provided with a slotted recess, *a*<sup>2</sup>, to pass over the projecting lug of the slide-rod, as shown in Fig. 2. The lifting of the block above the knife and the lowering of the same to be fed against the knife is thus accomplished in perfectly reliable and automatic manner, and without being interfered with by the weight of the pressure-roller, as the same is supported in the extension-frame B' of the carrier clear of the block when the lifting-rollers are thrown into operation.

Having thus described my invention, I claim as new and desire to secure by Letters Patent—

1. A machine for cutting hat-box boards, consisting of a reciprocating block-carrier, weighted pressure-roller, adjustable cutting-knife, and vertically-movable lifting-rollers, the whole being constructed and operated substantially as and for the purpose set forth.

2. The combination of the reciprocating block-carrier with a notched slide-rod having projecting ends, and with block-lifting rollers at both sides of the cutting-knife, substantially as specified.

3. The box-shaped carrier B, having extension-frame B' for supporting the pressure-roller when the lifting-rollers are thrown up, substantially as set forth.

4. The extension-frame B' of carrier B, having slotted recess *a*<sup>2</sup> for passing over projecting lug or end of roller operating slide-rod, substantially as set forth.

WILLIAM JENKINS.

Witnesses:

THEODORE PIERSON,  
DANIEL BROWN.