

H. H. KINGSBURY.
MILK-PAILS.

No. 183,176.

Patented Oct. 10, 1876.

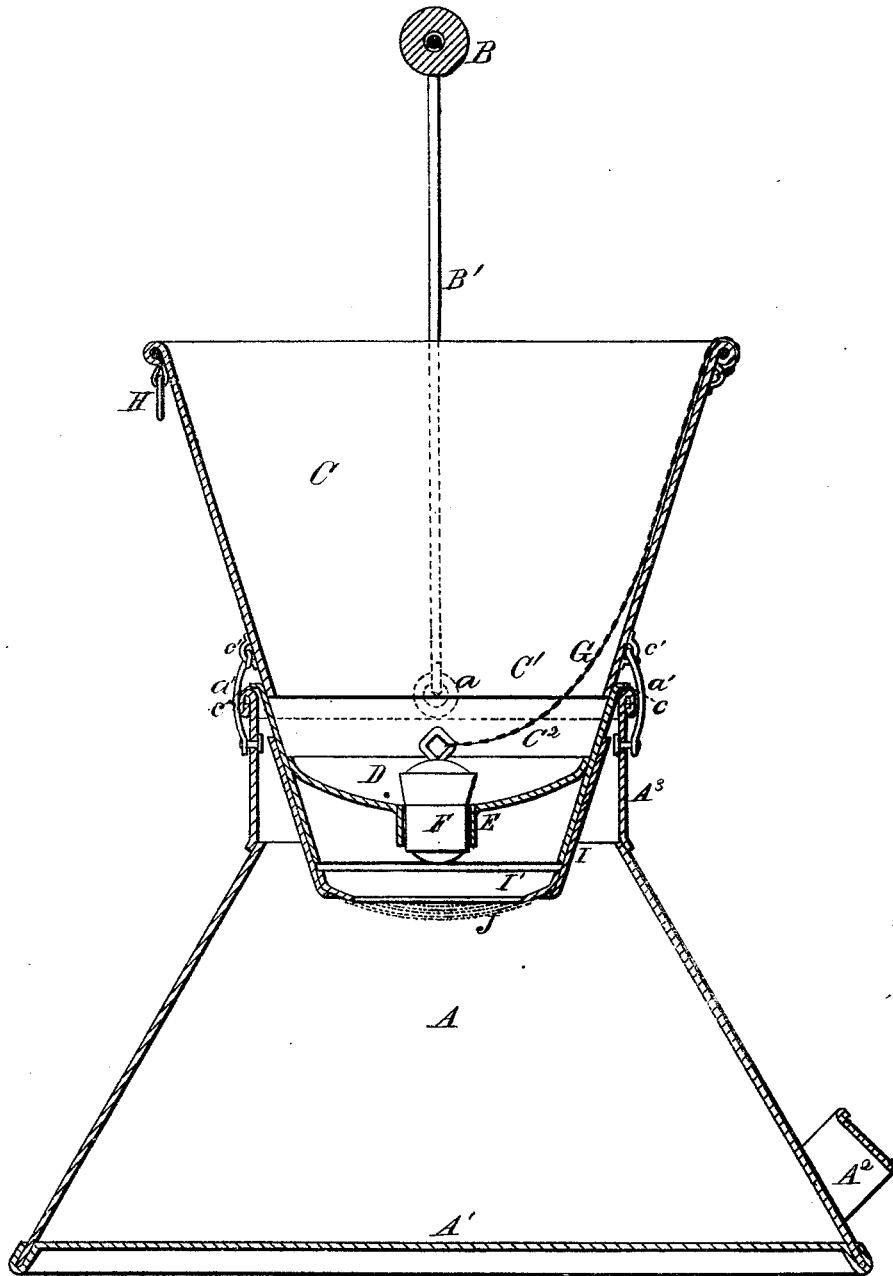

WITNESSES
Chas. R. Searle
John F. Ackers.

INVENTOR
Hiram H. Kingsbury.
Gilman & Smith Co.
ATTORNEYS

UNITED STATES PATENT OFFICE.

HIRAM H. KINGSBURY, OF OLNEY, ILLINOIS.

IMPROVEMENT IN MILK-PAILS.

Specification forming part of Letters Patent No. **183,176**, dated October 10, 1876; application filed September 2, 1876.

To all whom it may concern:

Be it known that I, HIRAM H. KINGSBURY, of Olney, in the county of Richland and State of Illinois, have invented a new and valuable Improvement in Milk-Buckets; and I do hereby declare that the following is a full, clear, and exact description of the construction and operation of the same, reference being had to the annexed drawings, making a part of this specification, and to the letters and figures of reference marked thereon.

The figure of the drawing is a representation of a central vertical section of my milk-bucket.

This invention relates to milk-buckets; and it consists, first, in providing said buckets with a flaring bottom, to prevent them from being tipped over. It also consists in so constructing said buckets that the milk obtains access to them only through a small tube, so that the milk will not readily run out even when overturned. It also consists in the combination, with said bucket and funnel, of a detachable strainer. It also consists in making said funnel sufficiently small in its upper diameter to materially lessen the amount of hairs and other impurities liable to fall therein.

In the annexed drawing, A designates a milk-bucket of conoidal shape, expanding downward to its bottom A¹, and provided with a side handle, A², near said bottom. The upper end of said bucket is provided with a vertical cylindrical extension, A³, rigidly secured thereto. At the upper end of said extension A³ are secured two opposite ears, *a a*, in which is hung the bail B' of an ordinary handle, B. Hooks *a' a'* are pivoted to said extension A³, midway between said ears *a a*, and opposite to one another. C designates a funnel or upper bucket, consisting of two rigidly-attached parts, C¹ C², and having, as a whole, the external shape of an inverted truncated cone. At the junction of said parts C¹ C² is an annular external horizontal supporting-flange, *c*, which rests upon the upper edge of extension A³ when the lower end of said funnel or upper bucket is set into said extension. On the sides of said lower part C² of said funnel are rigidly secured eyes, staples, loops, or perforated lugs *c' c'*, which are adapted to receive hooks *a' a'*, already described, and thereby to attach the

said funnel and bucket together. On the inside of said funnel C, near the lower end thereof, is rigidly secured a concave bottom, D, which terminates centrally in a downwardly-extending tube, E, which is adapted to receive a plug, F, secured to the top of said funnel by a short chain or cord, G. Said funnel is also provided at or near its upper end with a small pivoted loop-handle, H. I designates an inverted conoidal metal cap or cup, adapted to fit tightly upon the lower end of said funnel C, but detachable therefrom. The bottom of said cup is concave, and consists partly of an annular flange, I', and partly of a central strainer, J.

The operation and mode of application of the above devices are as follows: Cap I is first fitted upon the lower end of funnel C. Said lower end of said funnel, covered by said cap, is then set into upward extension A³ of bucket A, so that flange *c* rests upon the upper end of said extension A³. Said bucket A and funnel C are then locked together by means of hooks *a' a'* and eyes, or their equivalent, *c' c'*. Said funnel is then placed so as to receive the milk from the cow, plug F having been withdrawn from tube E. The said funnel is constructed of much smaller diameter than that of an ordinary milk-bucket, or than the greatest diameter of bucket A, and therefore will receive a less amount of hairs and impurities, and very little of such impurities as are received in said funnel will pass through narrow tube E to the milk below. The downwardly and outwardly flaring shape of bucket A tends to prevent it from being overturned during the process of milking or after the milking is concluded; and the narrowness of the upper inlet-tube E, together with the interposition of strainer J, prevents the milk from being immediately lost in case of such an overturning. By giving the operator time to right said bucket before much of the milk is lost, it is productive of a very great saving. Said strainer is also extremely useful in preventing impurities from passing down with the milk. When the strippings are reached plug F is inserted in tube E, and said strippings are drawn into funnel or upper bucket C, which is then used as a bucket and not as a funnel. This construction and mode of operation en-

ables me to keep the milk and strippings from mingling, and at the same time obviates the need for two separate vessels, as said funnel and bucket, when fastened as described, are carried by the same handle. The said parts may, however, be detached and used separately.

I do not confine myself to the precise form and construction shown. Bucket A may be pyramidal instead of conoidal; cup I may be permanently secured to funnel C; extension A³ may be dispensed with, and various other changes may be made without departing from the spirit of my invention.

Any suitable material may be used, though for most of the parts named ordinary sheet-iron is preferred.

The said devices may be applied to hold any other liquid as well as milk.

What I claim as new, and desire to secure by Letters Patent, is—

1. A bucket, A, having an expanded bottom and a narrow inlet-tube, A³, substantially as set forth.

2. The combination of a bucket, A, with an upper vessel, C, adapted to be used substantially as set forth.

3. In combination with bucket A and funnel C, a detachable cap, I, and strainer J, substantially as set forth.

In testimony that I claim the above I have hereunto subscribed my name in the presence of two witnesses.

HIRAM H. KINGSBURY.

Witnesses:

HIRAM SHARP,
E. Y. DOAN.