

B. G. MARTIN.  
GRINDING-MILL.

No. 183,184.

Patented Oct. 10, 1876.

Fig. 2.

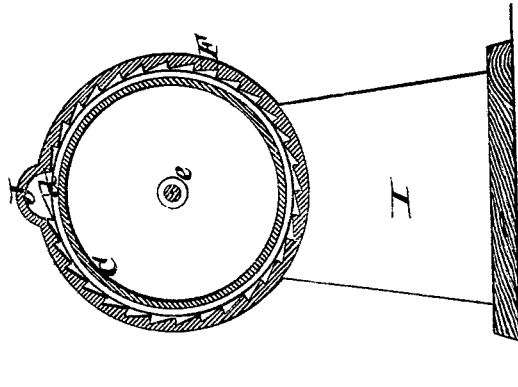
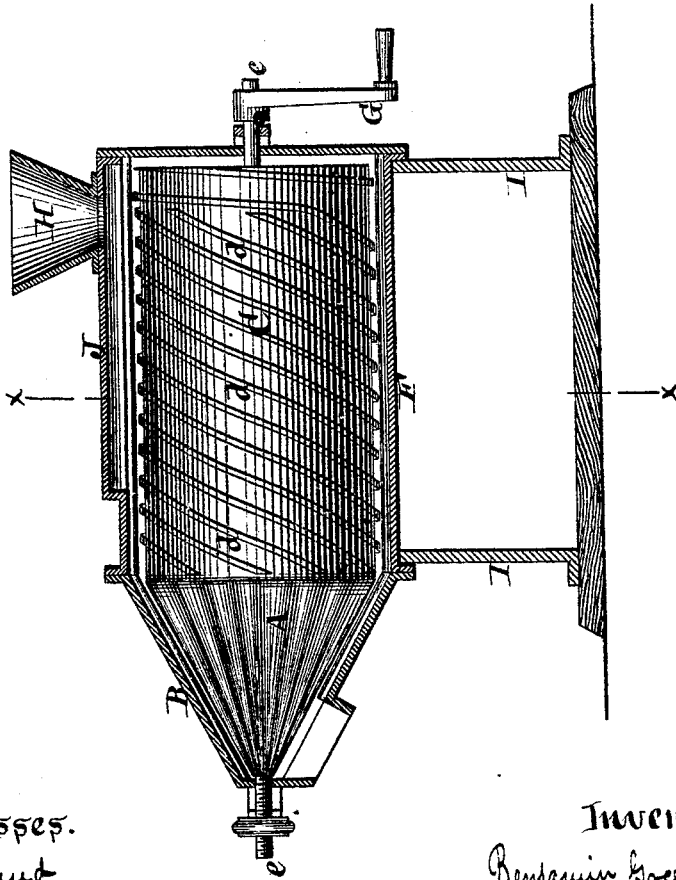

Fig. 1.



Witnesses.  
Otto Aufeland  
Coat. E. Miller.

Inventor.  
Benjamin Green Martin  
Van Santvoord & Hauff  
his attorneys

# UNITED STATES PATENT OFFICE.

BENJAMIN G. MARTIN, OF NEW YORK, N. Y.

## IMPROVEMENT IN GRINDING-MILLS.

Specification forming part of Letters Patent No. 183,184, dated October 10, 1876; application filed September 2, 1876.

*To all whom it may concern:*

Be it known that I, BENJAMIN G. MARTIN, of the city, county, and State of New York, have invented a new and useful Improvement in Grinding-Mills, which improvement is fully set forth in the following specification, reference being had to the accompanying drawing, in which—

Figure 1 represents a longitudinal vertical section of my improvement. Fig. 2 is a vertical cross-section thereof, taken in the plane *x x*, Fig. 1.

Similar letters indicate corresponding parts.

My improvement is especially adapted to that class of mills in which the grinding parts consist of a metallic cone, revolving within a correspondingly-shaped shell or concave; and it consists in combining a crushing-cylinder, which is provided with one or more spiral blades on its outer surface, and a crushing-shell with said grinding-cone and grinding-shell, the whole being so arranged that when corn or other grain is fed to the crushing-shell, and a revolving motion is imparted to the crushing-cylinder, the material is crushed by the action of the said cylinder and shell, while at the same time it is conveyed in a crushed state to the grinding-cone, and by this means the operation of grinding the material is greatly facilitated. It consists, also, in forming a chamber on the upper part of the crushing-shell to receive the material to be ground, and by which such material is fed uniformly to the shell, as hereinafter fully set forth.

In the drawing, the letter A designates the grinding-cone, and B is the grinding-shell or concave of my mill, which parts are made of the usual shape. C is the crushing-cylinder, on the outer surface of which are arranged a series of spiral blades, *d*. This cylinder C is mounted on a shaft, *e*, having its bearings at one end in the head of the crushing-shell, marked F, and at the other end in the end of the grinding-shell B; and to this shaft *e* is secured a winch, G, for giving motion thereto and to the crushing-cylinder. The inner sur-

face of the crushing-shell F is roughened, as shown in Fig. 2, in any suitable way, and on the upper part of said shell is placed a hopper, H. Said shell F, moreover, is supported on standards I I. The grinding-cone A and crushing-cylinder C are cast or otherwise formed in one piece, so that one forms a continuation of the other. The material to be ground is placed in the hopper H, and is thereby fed to the crushing-shell F, the crushing-cylinder C being at the same time revolved, so that the material is caught or taken up between the spiral blades *d* of said cylinder, and is thereby carried forward to the grinding-cone A. As the material is carried forward by the spiral blades *d*, it is rubbed against the inner surface of the shell F, and by this means it becomes broken or crushed previous to being ground. The letter J designates a chamber formed on the upper part of the crushing-shell, F. This chamber J is situated adjacent to the hopper H, and extends nearly the entire length of the shell F, so that the material placed in the hopper H fills up the chamber, and is thereby fed uniformly to the crushing-shell.

What I claim as new, and desire to secure by Letters Patent, is—

1. The combination, with the crushing-cylinder C, provided with a grinding-cone at one end, and with spiral blades around the cylindrical portion, of the casing F, provided with a longitudinal feed-chamber, J, on top, and a concave grinding-chamber at one end, substantially as herein set forth.

2. In combination with the crushing-cylinder C and casing F, the longitudinal semi-cylindrical feed-chamber J, with plain inner surface, located above the crushing-cylinder, substantially as herein set forth.

In testimony that I claim the foregoing I have hereunto set my hand and seal this 30th day of August, 1876.

B. G. MARTIN. [L. S.]

Witnesses:

J. VAN SANTVOORD,  
E. F. KASTENHUBER.