

H. MILLWARD.

REVOLVING DOORS FOR BURGLAR-PROOF SAFES.

No. 183,192.

Patented Oct. 10, 1876.

Fig. 1

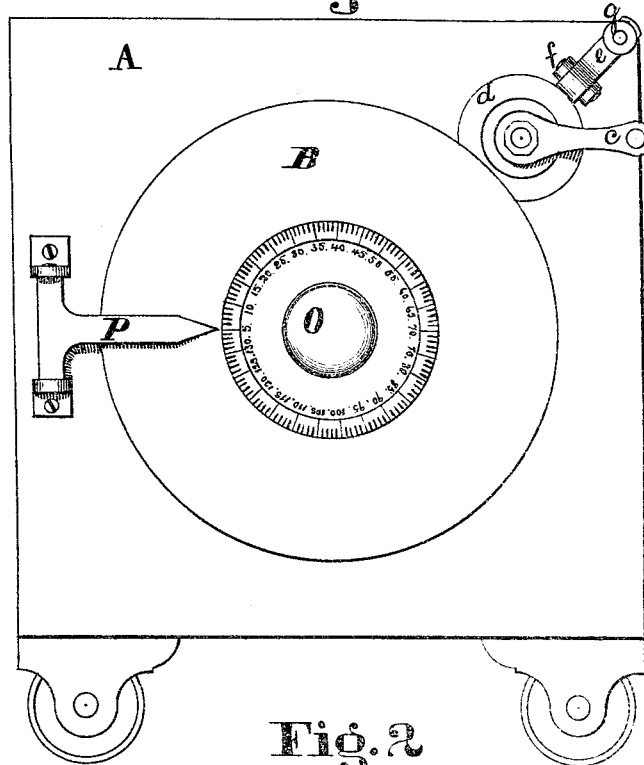
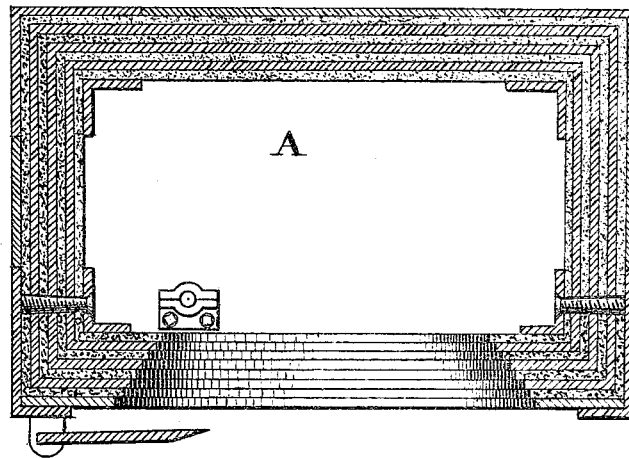

Fig. 2



Attest
Chas. Gessert
Chas. Serapsey

Inventor
H. Millward
3

H. MILLWARD.
REVOLVING DOORS FOR BURGLAR-PROOF SAFES.
No. 183,192. Patented Oct. 10, 1876.

Fig. 3

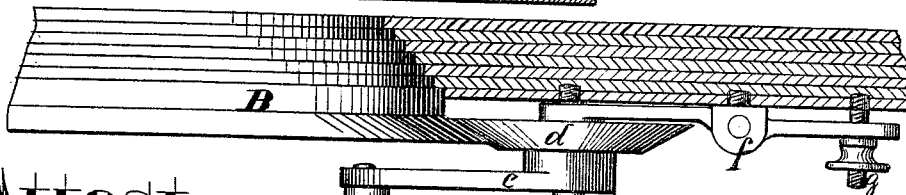
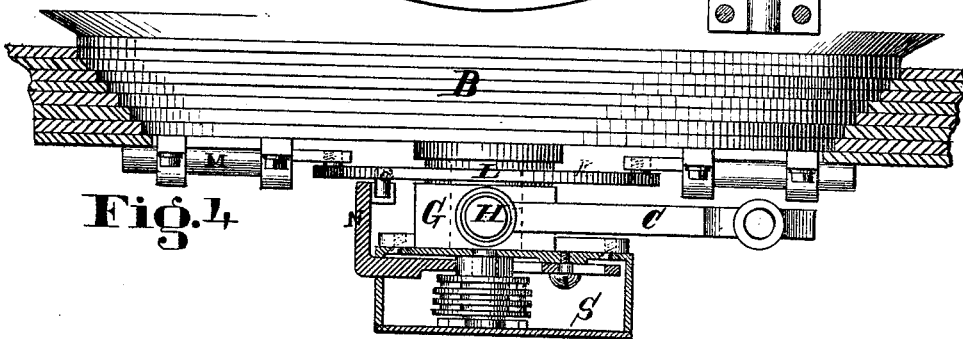
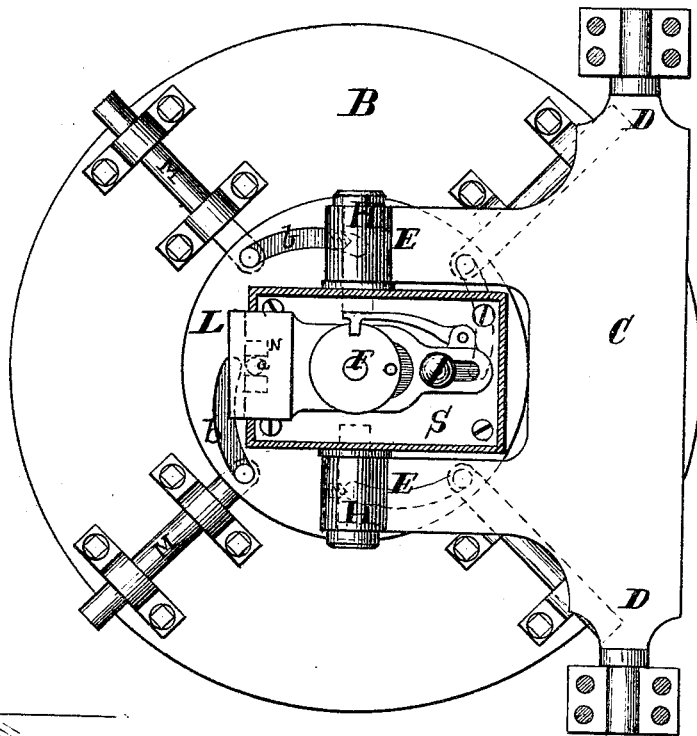

Attest
Chas. Gessert
Chas. Corapay

Fig. 5

Inventor
Henry Millward
3

H. MILLWARD.
REVOLVING DOORS FOR BURGLAR-PROOF SAFES.
No. 183,192. Patented Oct. 10, 1876.

Fig. 6

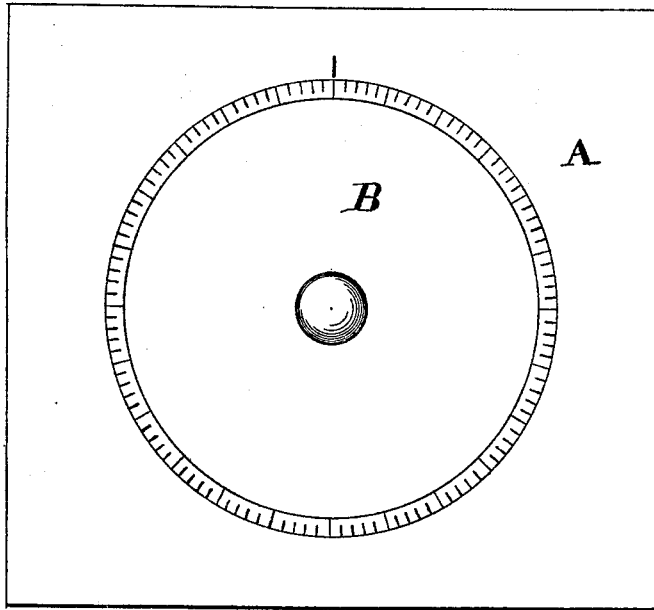
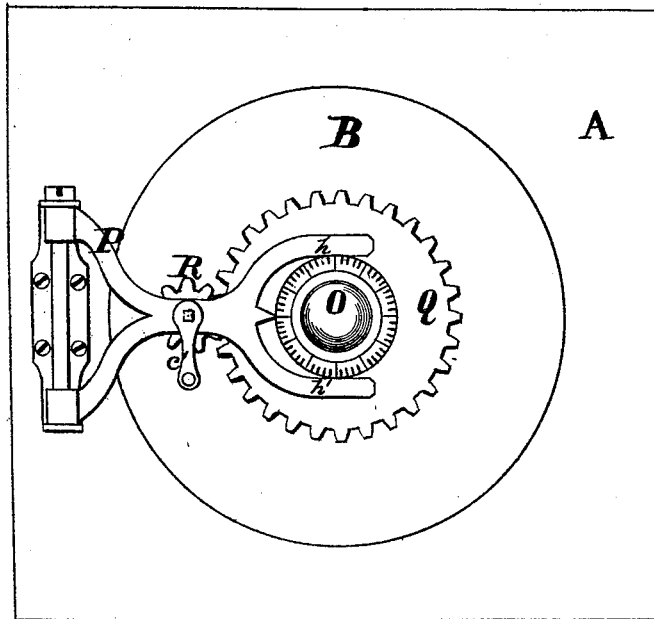

Fig. 7



Attest
Chas. Gessert
Jos. L. Marty

Inventor
Henry Millward

H. MILLWARD.
REVOLVING DOORS FOR BURGLAR-PROOF SAFES.
No. 183,192. Patented Oct. 10, 1876.

Fig. 8

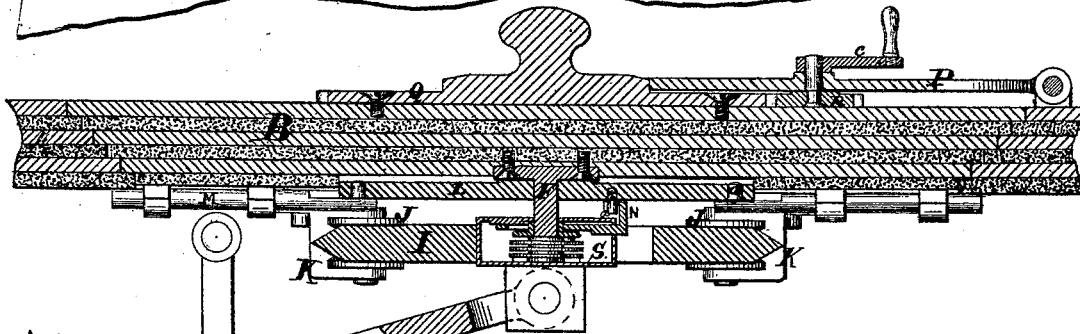
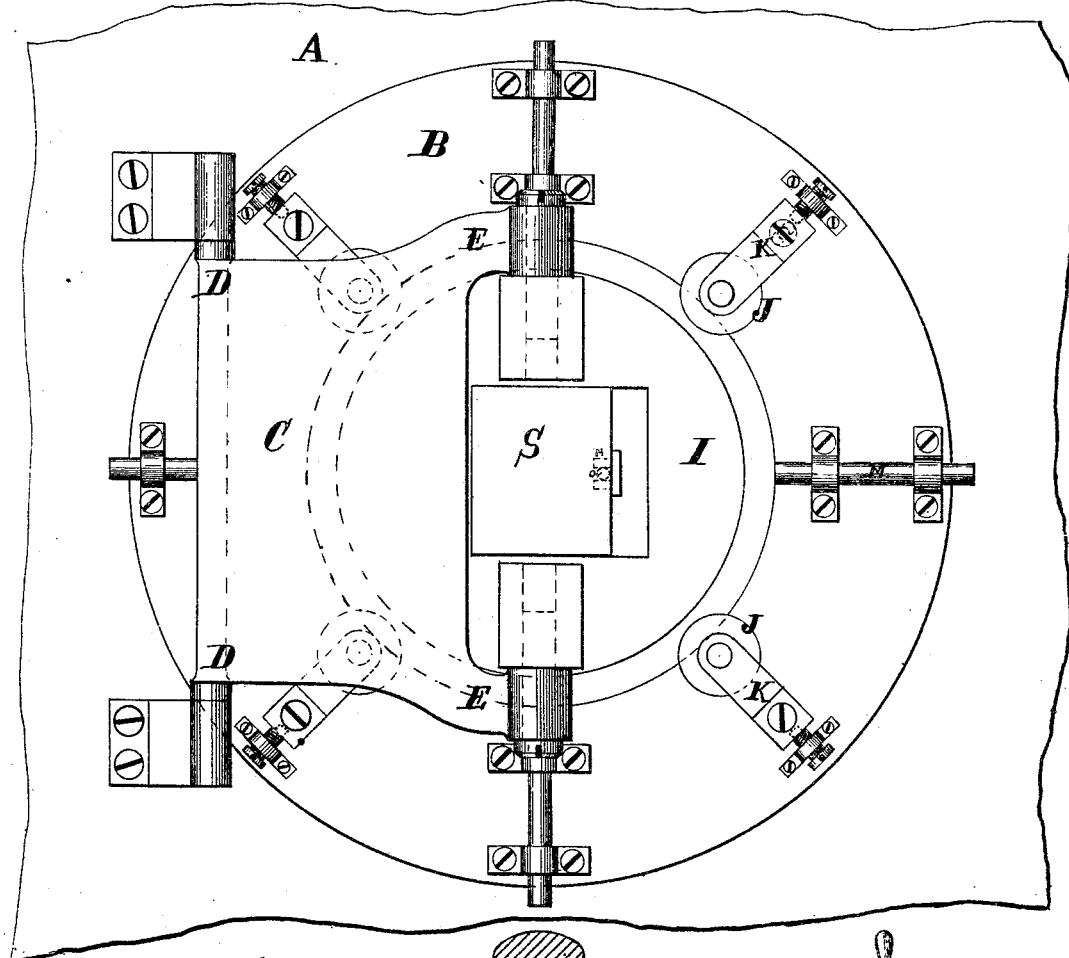

Attest
Chas. Gessert
Chas. Crapey

Fig. 9

Inventor
H. G. Millward

UNITED STATES PATENT OFFICE,

HENRY MILLWARD, OF CINCINNATI, OHIO.

IMPROVEMENT IN REVOLVING DOORS FOR BURGLAR-PROOF SAFES.

Specification forming part of Letters Patent No. 183,192, dated October 10, 1876; application filed December 28, 1875.

To all whom it may concern:

Be it known that I, HENRY MILLWARD, of Cincinnati, in the county of Hamilton and State of Ohio, have invented certain new and useful Improvements in Burglar-Proof Safes, of which the following is a specification:

My invention relates to certain improvements in the construction of fire-proof safes; and it consists in providing the safe with a circular door and lock secured to a common hinge, the said door being arranged to revolve upon the hinge in such manner as to operate the permutation-lock and bolts of the same; also, in the combination, with the revolving door of a dial and hinged pointer, for representing the position of the tumbler-slots, as more fully hereinafter set forth; and, further, in the combination, with the revolving door and the bolts thereof, of a slotted disk-bolt and permutation-lock, operated by the rotation of the door, as more fully hereinafter specified.

In the accompanying drawings, Figure 1 is a vertical front elevation of a safe of my invention. Fig. 2 is a sectional plan of the front part of the same with the door removed. Fig. 3 is a vertical elevation of the door, looking from the inside of the safe; and Fig. 4 is a sectional plan of same. Fig. 5 is a partial sectional plan view, representing the attachment of friction-gear to the door. Fig. 6 is a vertical elevation of a safe of my invention, showing another method of indicating the position of the tumbler-slots. Fig. 7 is a vertical elevation of a safe, showing another method of revolving the door by spur-wheels. Fig. 8 is a vertical elevation of a safe, looking from the inside, and represents a method of attaching one end of the hinges to a ring, and revolving the door upon it by means of friction-rollers attached to the door by adjustable brackets, and so arranged as to cause the door to move around the said ring and with it, while the door is swinging upon its hinges; and Fig. 9 is a partial sectional plan of the same, and representing the hinges shaped in such a manner as to allow the door to swing clear around the side of the safe.

A is the body of a safe, of which B is the door, swinging upon a crane-hinge, C, located on the interior of a safe, the hinge C being

firmly secured at the end D to the body of the safe, and the end E to the door, in such a manner as to allow the door to revolve freely, or to oscillate in a horizontal direction. In Figs. 3 and 4 the door is represented as revolving upon a pintle, F, which is firmly secured to the door and fitted to rotate in the journal-block G, to which the hinge C is pivoted at H. In Figs. 8 and 9 the door is represented as being attached to the hinge C by means of a disk, I, upon which the door is made to revolve by means of friction-rollers J, firmly secured to the door by the adjustable brackets K. In Figs. 3 and 4 the lock S is represented as attached to the journal-block G, and in Figs. 8 and 9 to the disk I.

On the pintle F is mounted a slotted disk, L, through means of which the bolts M are operated. A jaw on the lock-bolt N is arranged to engage with a pin, *a*, on the disk L, when the bolt N is drawn in or unlocked, and cause the disk L to remain stationary while the door and the bolts M are moved around, causing the bolts M, one part of which moves in the slots *b*, to be drawn in or out, according as the door is moved to the right or left. When the lock-bolt N is out or locked, the jaw of the same is removed from the pin *a*, and the disk L moves with the door without changing its position in relation to the door.

In Fig. 1 the door is represented as being revolved by friction-gear operated by a crank, *c*. The exterior plate of the safe-door is made to project past the body of the safe a sufficient distance to allow of the friction-roller *d* acting upon the inclined or grooved periphery of the same, the amount of friction applied being regulated by a lever, *e*, which has its fulcrum at *f*, and moves the roller *d* against the friction-surface on the outer door-plate by a screw and nut, *g*.

In Fig. 1 the positions of the tumbler-slots are represented as being indicated by placing a dial, O, in the center of the door, and a hinged pointer, P, extending from the body of the safe to the dial O. In Fig. 6 the dial and pointer are represented as being dispensed with by placing the figures around the outer rim of the exterior door-plate, and a fixed mark made on the body of the safe. In Fig.

7 the hinged pointer P is represented as being forked, with the ends *h h'* resting upon the periphery of the dial O, and a cog-wheel, Q, firmly attached to the door on the exterior plate, is operated by a spur-wheel, R, which is journaled in the pointer P, turned by crank *c'*.

What I claim as new, and desire to secure by Letters Patent, is—

1. A circular door, B, and lock S, secured to a common hinge, C, the said door being arranged to revolve upon the hinge in such manner as to operate the permutation-lock S and the bolts M, substantially as described.

2. In combination with the revolving door, the dial O and hinged pointer P, secured to the front of the safe, substantially as described.

3. On a revolving door, the combination of the bolts M, slotted disk L, and bolts N of the permutation-lock S, operated by the rotation of the door, substantially as described.

In testimony whereof I have hereunto set my hand this 22d day of November, 1875.

HENRY MILLWARD.

Witnesses:

JNO. P. MURPHY,
CHAS. CRAPSEY.