

W. T. MOFFATT.

MACHINE FOR PLACING CAPSULES ON BOTTLES.

No. 183,193.

Patented Oct. 10, 1876.

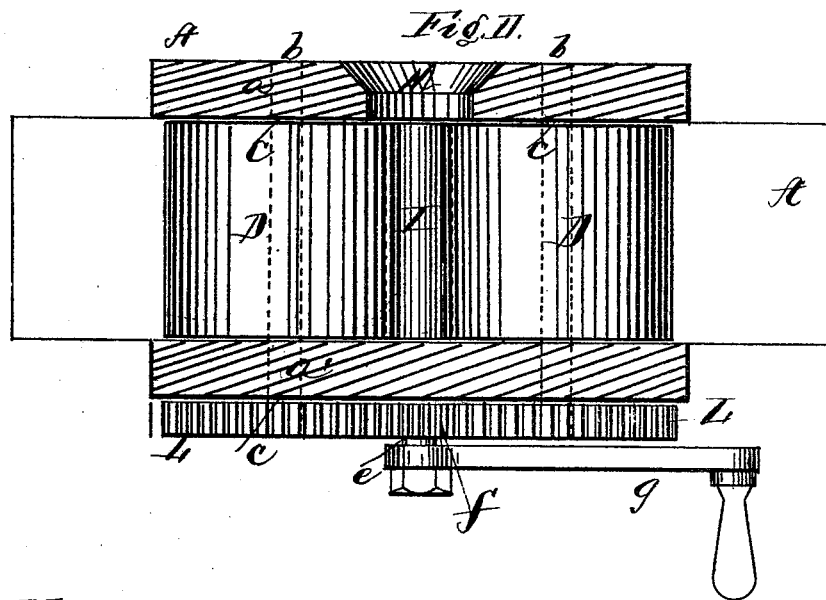
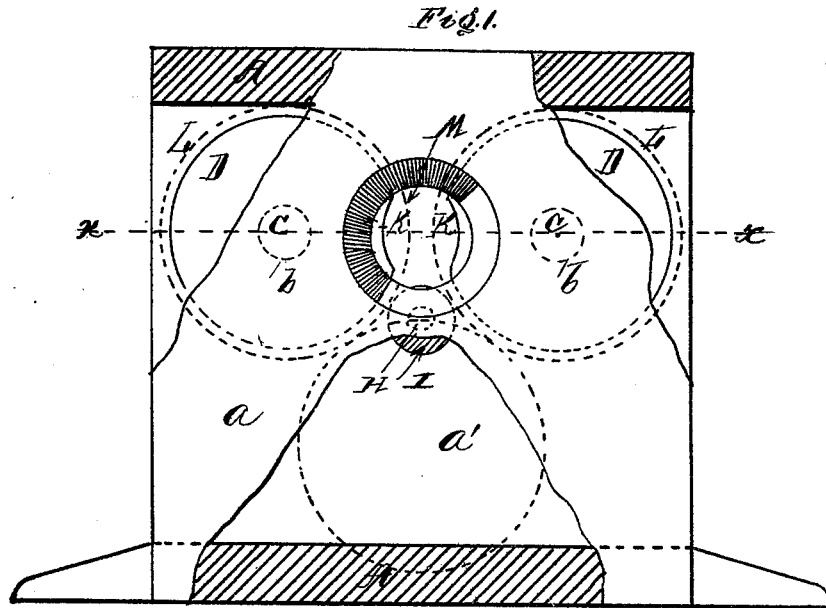

Witnesses:
Franklin Barnett
Richard Germer.

Inventor:
William T. Moffatt.
Per: Henry Germer.
Atty.

UNITED STATES PATENT OFFICE.

WILLIAM T. MOFFATT, OF NEW YORK, N. Y., ASSIGNOR TO CHARLES E. BARNETT, OF SAME PLACE.

IMPROVEMENT IN MACHINES FOR PLACING CAPSULES ON BOTTLES.

Specification forming part of Letters Patent No. **183,193**, dated October 10, 1876; application filed March 27, 1876.

To all whom it may concern:

Be it known that I, WILLIAM T. MOFFATT, of New York city, county and State of New York, have invented certain Improvements in Machines for Placing Capsules on Bottles, of which the following is a specification:

The object of my invention is to provide for a cheaply and readily constructed machine, by aid of which the commonly-used capsules or caps of tin may be placed over the top and neck of any kind of bottles more quickly, cheaper, and better than can be done by the heretofore-known methods.

My invention consists of constructing a suitable frame, having two vertical parallel sides, between which are placed, at suitable distance apart, two axles, revolving horizontally in journals in the vertical sides of the frame. The axles form the center of india-rubber rollers, which are securely fastened to the same. The rollers, which may also, if so desired, be made of any other suitable flexible substance than india-rubber, are each provided with a longitudinal groove of suitable size to allow the neck of a bottle to be pushed in between the opening thus formed by the groove and rollers.

In order to give the neck of the bottle a place to rest on when operated upon, a third and smaller roller is placed also on an axle in the same manner as the two other rollers immediately under and between the same. The two larger rollers are revolved by gear-wheels fastened to the ends of the axles, outside of one of the vertical sides, said gear-wheels meshing into a third gear-wheel placed below the others, and fastened to an axle running through both sides of the frame, and revolving in suitable journals therein. A crank placed on the end of this axle, on the same side as the gear-wheels, serves to give rotation to the axles and the grooved rollers.

In order to operate the machine, it is only required to turn the crank until the two fore-mentioned grooves in the upper rollers come opposite each other. The bottle to be capped, after the capsule-cap is put on loosely over the top of the neck, is then grasped by the hand at the side and bottom, and the capped neck is then pushed into the space formed between the walls of the grooves in the two rollers and the top of the small roller beneath them.

An opening of sufficient size is provided for in the side of the frame, in order to readily place the bottle in the space between the rollers. The crank, being turned, revolves the two upper rollers, the sides of which are pressing on the capsule on the neck of the bottle all around, and causes also the bottle to revolve, while the third smaller roller revolves on account of the revolving motion given to the neck of the bottle when pressing against the top of the roller.

The capsule or cap is also made to be smoothed evenly down on the top of the cork placed in the opening of the neck, by pushing the bottle so far in between the rollers that the end of the capsule or cap comes against the inner side of the vertical wall, opposite the opening through which the bottle-neck is introduced into the forementioned space between the rollers.

In order to describe my invention more fully, I refer to the accompanying drawing, forming a part of this specification.

Figure I represents a side view of a machine embodying my invention, with part of the outer casing removed. Fig. II is a plan sectional view of the same through line *x x*, Fig. I.

A is the frame, with the two vertical sides *a* and *a'*, in which are inserted the journals *b* *b* for the axles *c c* of the grooved rollers D D, and for the axle *e* of the gear-wheel *f* and the crank *g*, and also for the axle *h* of the small roller I. K K are the grooves in the rollers D D. L L are the gear-wheels, fastened to the axles *c c*, and meshing into the gear-wheel *f*. M is the hole or opening in the vertical side *a*, through which the neck of the bottle is inserted in the space between the walls of the grooves K K and the small roller I.

Having thus described my invention, I desire to claim—

A machine for capping bottles, consisting of the grooved rollers D D and the roller I, all operated as described, in combination with the frame A, substantially as set forth.

This specification signed this 14th day of August, 1875.

WILLIAM T. MOFFATT,

Witnesses:

RICHARD GERNER,
W. RÜBSAMEN.