

A. L. & J. S. WAGGONER.  
STATION-INDICATOR.

No. 183,434.

Patented Oct. 17, 1876.

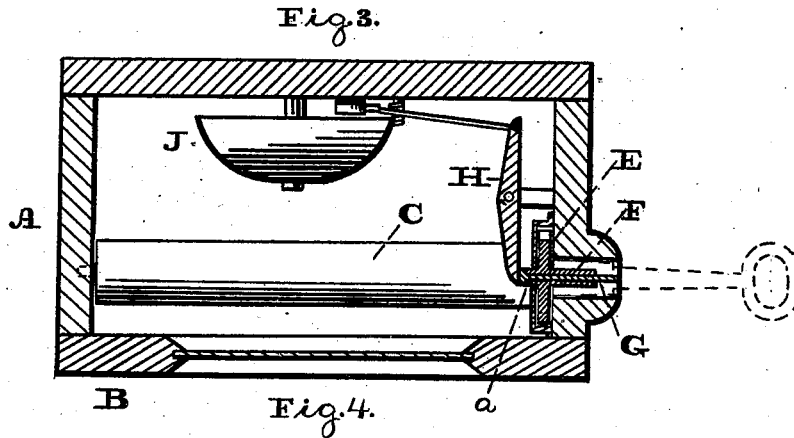
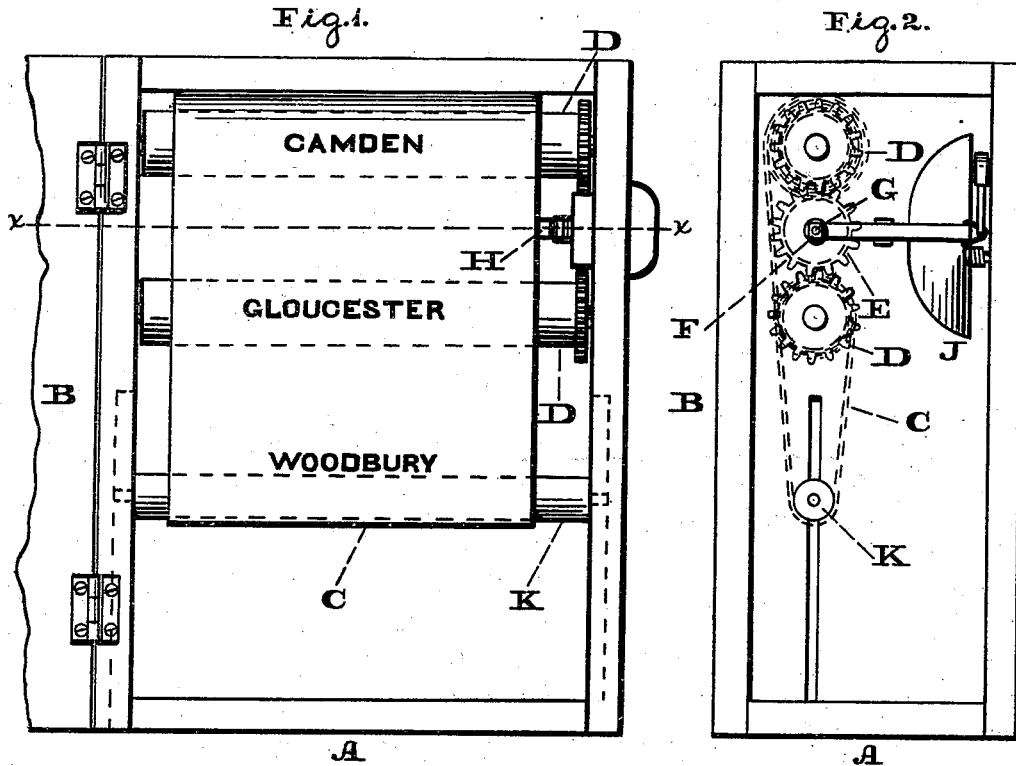

Witnesses:  
Lewis F. Brown  
A. P. Grant.

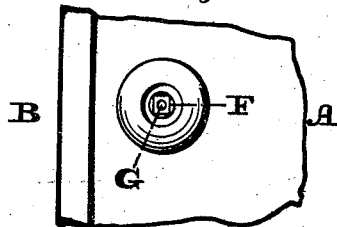

Inventors:  
Amasa L. Waggoner  
John S. Waggoner.  
by John Diederichsen  
Attorney.

# UNITED STATES PATENT OFFICE.

AMANDA L. WAGGONER AND JOHN S. WAGGONER, OF BRIDGEPORT, N. J.

## IMPROVEMENT IN STATION-INDICATORS.

Specification forming part of Letters Patent No. **183,434**, dated October 17, 1876; application filed September 1, 1876.

### *To all whom it may concern:*

Be it known that we, AMANDA L. WAGGONER and JOHN S. WAGGONER, of Bridgeport, in the county of Gloucester and State of New Jersey, have invented a new and useful Improvement in Station-Indicators; and we do hereby declare the following to be a clear and exact description of the nature thereof, sufficient to enable others skilled in the art to which our invention appertains to fully understand, make, and use the same, reference being had to the accompanying drawings, making part of this specification, in which—

Figure 1 is a front view of the interior of the device embodying our invention. Fig. 2 is a side view of the interior thereof. Fig. 3 is a horizontal section in line *xx*, Fig. 1. Fig. 4 is a side view of a portion thereof.

Similar letters of reference indicate corresponding parts in the several figures.

Our invention consists of rollers on which will be wound and unwound a sheet or apron on which are marked names of stations to be presented to the view of passengers, and to which attention will be directed by a gong or alarm, in combination with means for simultaneously shifting the sheet and operating the alarm.

Referring to the drawings, A represents a box or casing, having a door, B, which has a transparent face, through which the names of stations may be viewed, said names being printed or otherwise marked on a sheet or belt, C, arranged within the box A, and winding and unwinding on two rollers, D, placed parallel, one above the other, and geared together, so that as the sheet is wound on one roller it will unwind from the other, and vice versa. Intermediate of the gear-wheels of the rollers D there is a gear-wheel, E, which is formed with a boss, F, squared or angular, for application of a key, and consequent rotation of the rollers. The hub *a*, by which the wheel is mounted, and the boss F are hollow, and through them is passed a spindle, G, whose inner end is adapted to come in contact with a hinged arm, H, mounted within the case, one end of said arm H being connected to the operating mechanism of a bell or gong, J, secured within the casing. The outer end of the spindle G projects beyond

the boss F of the gear-wheel E, so that the socket of the key during the act of applying the key to the boss will come in contact with the spindle; and as the latter has a sliding motion, it will be evident that, owing to its projection beyond the boss, the latter cannot be reached by the key without forcing in the spindle, the boss and spindle being accessible at the side of the box A.

When the sheet C is to be shifted so that the station at which the train next arrives will come opposite to the transparent face or opening in the door B, the key is applied to the spindle and boss, as shown in Fig. 3. Force in the key so that it may be fitted on the boss, and in this operation the spindle will be pressed, so as to impart motion to the arm H, and, consequently, operate the bell-hammer, whereby the bell or alarm will be sounded, thus directing attention to the indicator. At the same time turn the key in the proper direction, so that the rollers D will be operated, and the name of the next station or next stopping-place marked on the sheet C will arrive opposite the transparent face or opening of the door, whereby said name may be readily seen and the station indicated. On withdrawing the key the parts return to their first position, the spring of the bell or gong being preferably employed to press against the arm H, which is in contact with the spindle G.

The operating mechanism of the hammer of the gong or bell may be of the order so as to cause the gong or bell to be struck both when the spindle is forced in and restored to its normal position.

As the sheet winds on one roller and unwinds on the other, it is evident that one roll of the sheet will become thinner than the other, and the sheet will unwind from the thick roll more rapidly than it is wound on the thin roll, consequently a length of the sheet will hang. To hold the sheet taut and take up the slack, we employ a weighted roller, K, which is guided between the sides of the box A, and rests on the fold of the sheet occasioned at the lowermost portion of the sheet, due to the slack thereof, as more readily seen in Fig. 2, whereby the roller presses down the slack and holds the sheet taut. When the sheet

winds on the thick roll and unwinds from the thin roll, the sheet will wind rapidly; consequently the hanging slack will be lessened, and the weighted roller will rise as the sheet is taken up, thus also preserving the taut of the sheet.

Having thus described our invention, what we claim as new, and desire to secure by Letters Patent, is—

The gear-wheel E and sliding spindle G fitted

therein, in combination with the sheet winding and unwinding rollers, and alarm-operating mechanism, substantially as and for the purpose set forth.

AMANDA L. WAGGONER.  
JOHN S. WAGGONER.

Witnesses:

JOHN WIEDERSHEIM,  
H. E. HINDMARSH.