

L. CHAPMAN.
GANG-PLOW.

No. 183,794.

Patented Oct. 31, 1876.

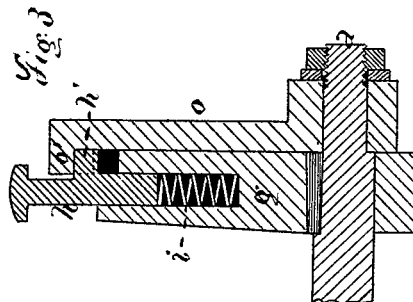
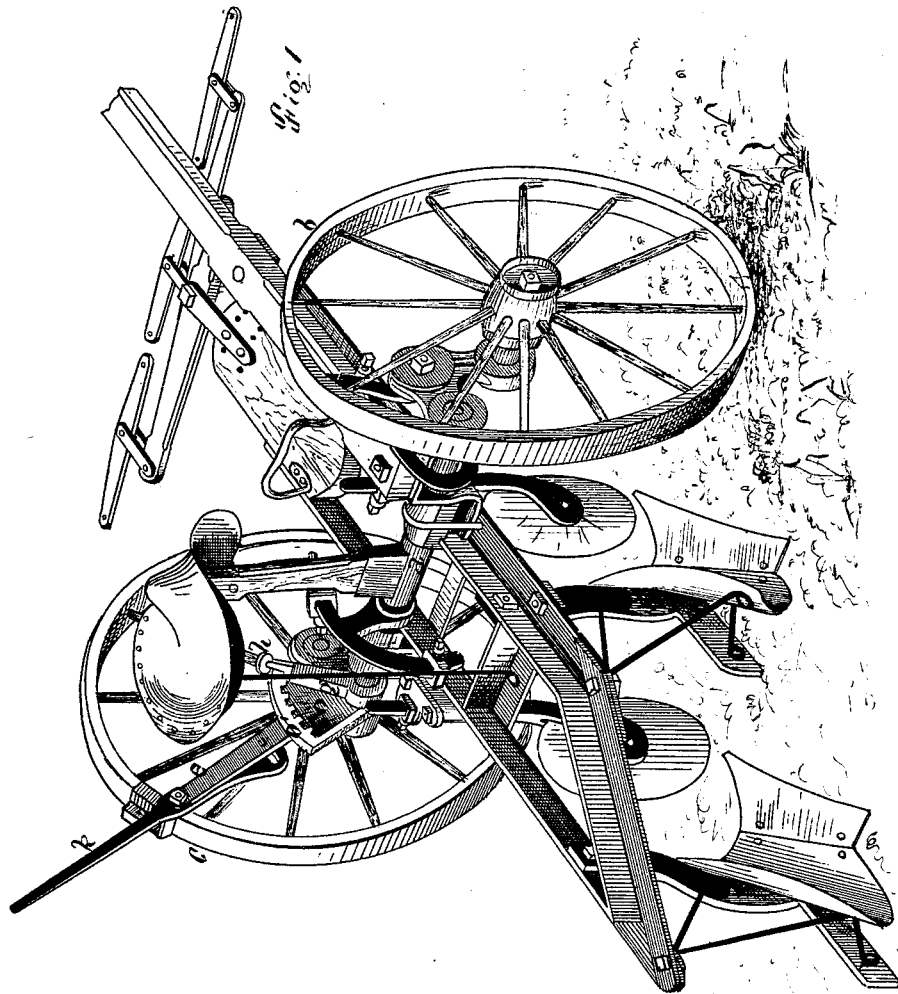

Witnesses
John Pollett
Robt. F. Gaylord

Inventor
Luke Chapman
By W. E. Simons
Atty

L. CHAPMAN.
GANG-PLOW.

No. 183,794.

Patented Oct. 31, 1876.

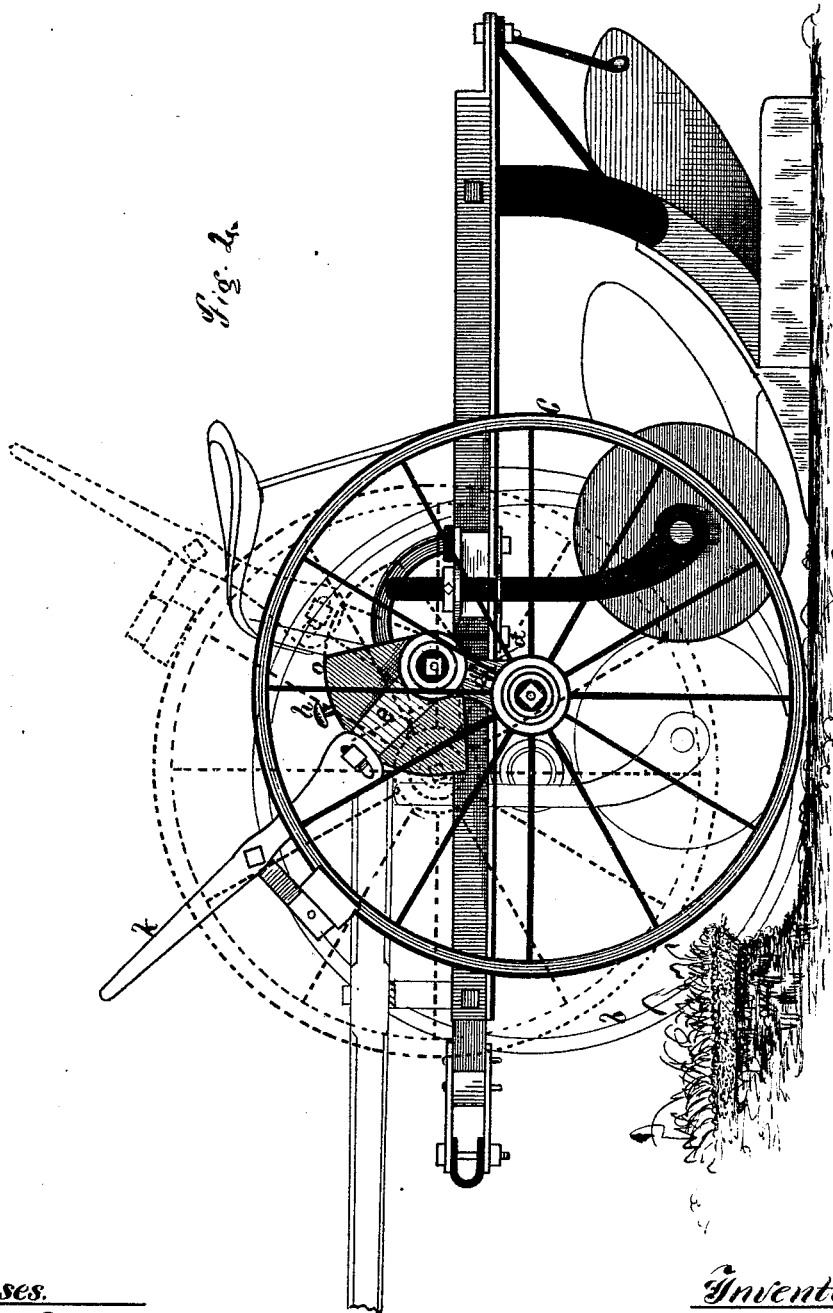

Witnesses.

John Pollitt
Robt. F. Gaylord

Inventor.

Luke Chapman
By W. C. Simonds
Att'y.

UNITED STATES PATENT OFFICE.

LUKE CHAPMAN, OF COLLINSVILLE, CONNECTICUT, ASSIGNOR TO THE
COLLINS COMPANY, OF SAME PLACE.

IMPROVEMENT IN GANG-PLOWS.

Specification forming part of Letters Patent No. 183,794, dated October 31, 1876; application filed
February 10, 1876.

To all whom it may concern:

Be it known that I, LUKE CHAPMAN, of Collinsville, in the county of Hartford and State of Connecticut, have invented certain new and useful Improvements pertaining to a Gang-Plow, of which the following is a specification, reference being had to the accompanying drawings, where—

Figure 1 is a perspective view from the rear, and, on the furrow-wheel side, in adjustment for regular work. Fig. 2 is a side elevation from the land-wheel side. Both land-wheel and furrow-wheel are on the same level, each supposed to be running in a furrow. The dotted lines show the land-wheel and other parts prepared to mount, or rather as just having mounted, the "land," through the action of the quadrant-arm, which forms the essential feature of this invention. Fig. 3 is a detail view of the quadrant-arm and adjacent parts in longitudinal central section.

The main features of the machine shown in these drawings have already been patented to me by prior patents; and it is not necessary to go into a description of all the parts and their operation in detail.

The letter *a* denotes the main shaft; *b*, the "furrow-wheel," (meaning the wheel which generally runs in the furrow,) and *c* the "land-wheel," (meaning the wheel which generally runs on the land.) This land-wheel is hung on the arm *d*, which is pivoted on the main shaft. From the arm *d*, and rigid with it, rises the lever *e*. Pivoted on the main shaft, and rigid with the arm *d*, (and, consequently, rigid with lever *e*,) is the quadrant-arm *o*, bearing the interior gear segment or ratchet *o'*. Fast on the main shaft rises the arm *g*, in which plays the reciprocating pawl *h*, pressed outward by spring *i*, pressing the tooth *h'* (borne upon the pawl *h*) into contact and mesh

with the ratchet *o'*. To illustrate the office and action of this quadrant-arm, suppose the whole machine to be adjusted for regular work, as shown in Fig. 1, with the furrow-wheel running in a furrow, and the land-wheel raised, and running on the land, and that, as happens when near the close of a piece of work, the land-wheel is about to drop into a furrow, (a thing which, uprovided for, would probably unseat the rider.) In such case the rider, putting his foot on the top of pawl *h*, presses the tooth *h'* from its mesh with ratchet *o'*, leaving arm *d* and land-wheel *c* to swing free on the main shaft; and, when thus permitted, the land-wheel drops to position shown in Fig. 2, thus keeping the seat erect.

When the land-wheel needs to rise from the furrow to land, (a position of affairs shown in Fig. 2,) the rider with his foot unlocks the quadrant-arm from the main shaft, and, with his hand on lever *k*, (which acts in conjunction with lever *e*,) draws this lever back, as shown in dotted lines in Fig. 2, and thereby raises the land-wheel to the level of the land.

I disclaim, in this application, all that I have shown in my application for patent for gang-plovs filed April 14, 1875, in so far as it resembles the invention herein described.

I claim as my invention—

The wheel *c*, hung on the arm *d*, the lever *e*, and toothed quadrant-arm *o*, all rigidly secured together, in combination with the rigid arm *g*, pawl *h*, and shaft *a*, all constructed and arranged for operation substantially as described.

In witness whereof I hereto set my hand.

LUKE CHAPMAN.

Witnesses:

WM. E. SIMONDS,
R. F. GAYLORD.