

E. EMMERT.
HARVESTER.

No. 183,801.

Patented Oct. 31, 1876.

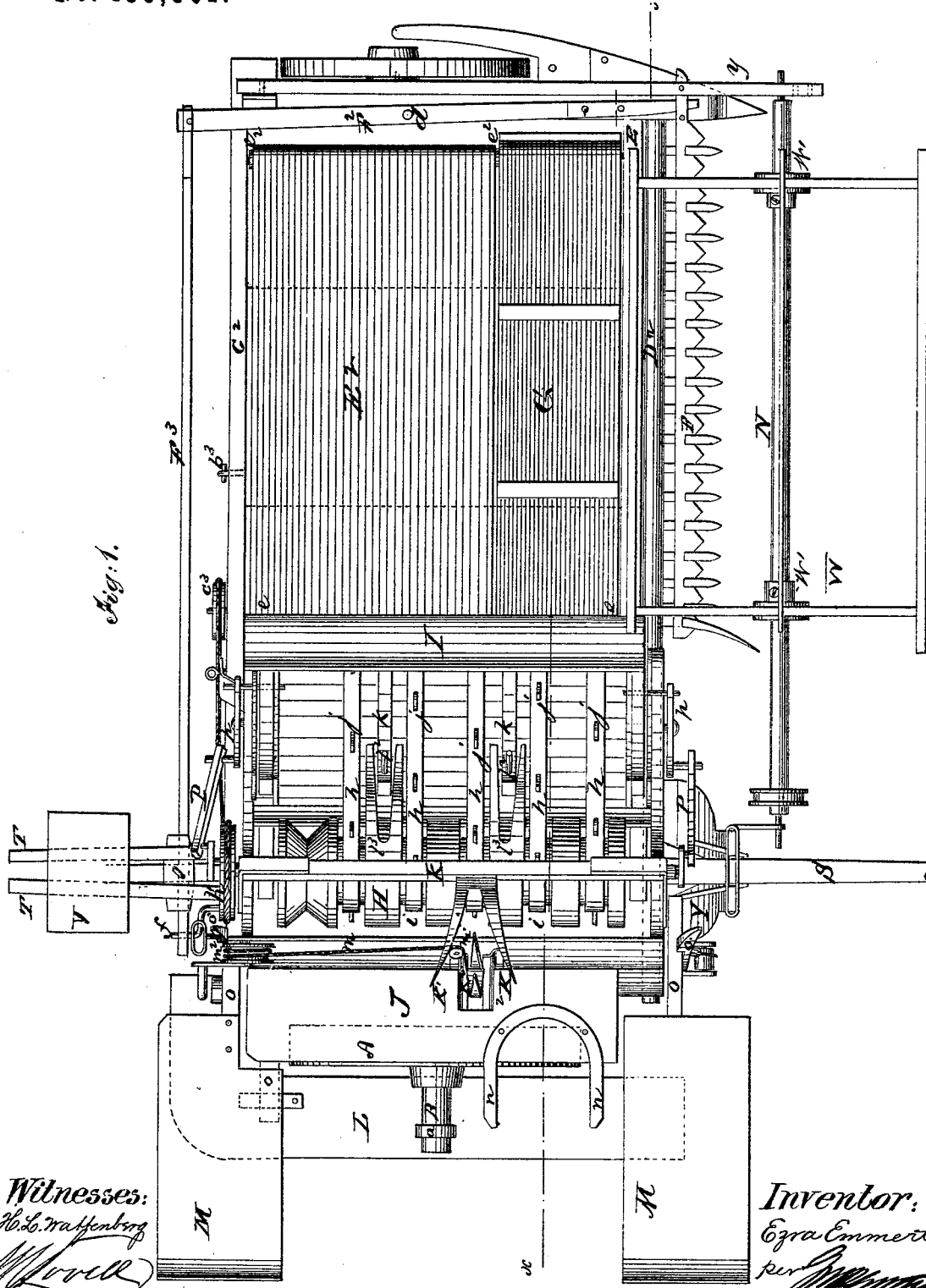

Aug. 1.

Witnesses:
H. S. Waffenberg
[Signature]

Inventor:
 Ezra Emmert
 per *[Signature]*
 Atty

E. EMMERT.
HARVESTER.

No. 183,801.

Patented Oct. 31, 1876.

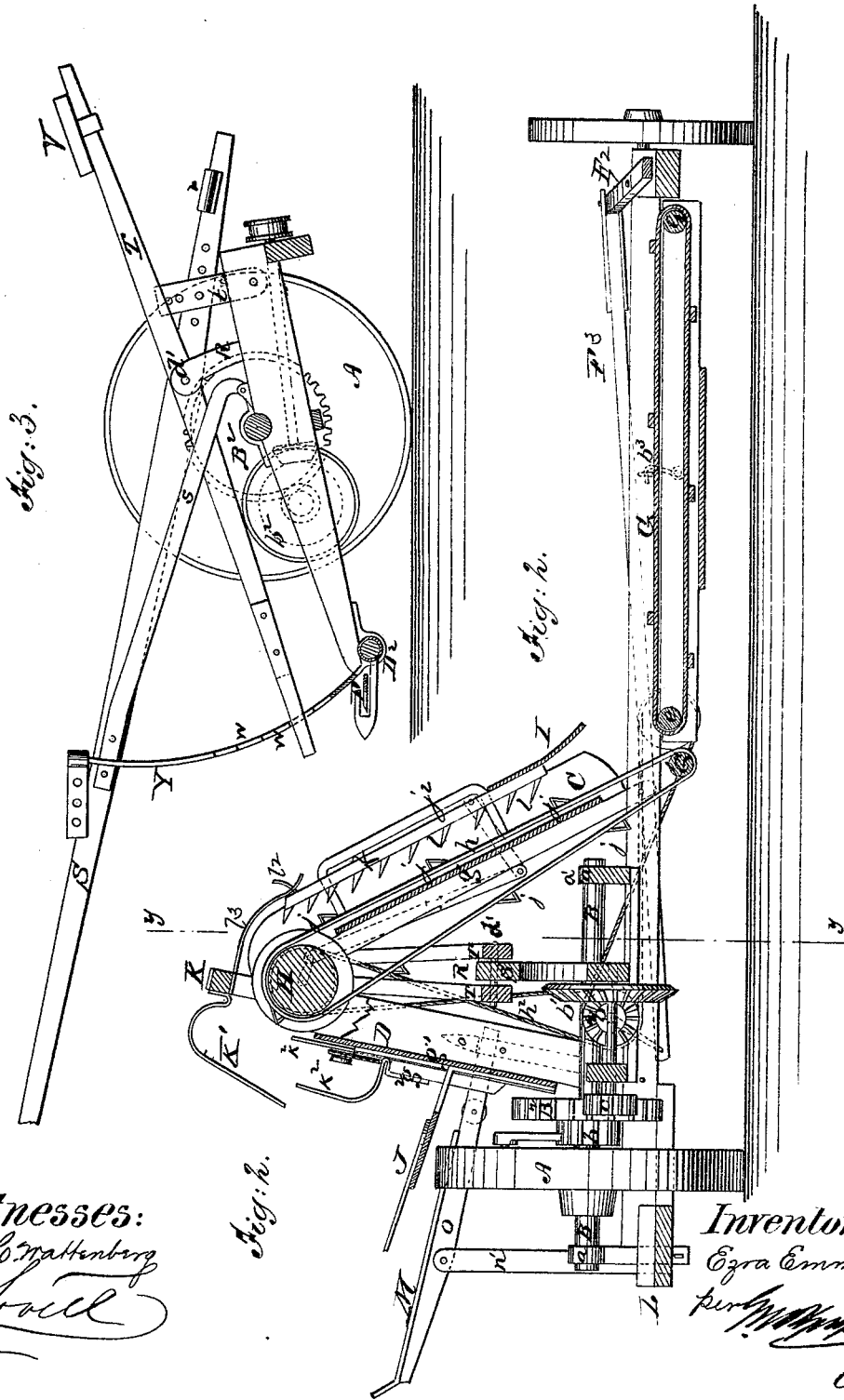

Witnesses:
H. L. Mattenberg
W. J. Hall

Inventor:
Ezra Emmert
Per [Signature]
Atty

E. EMMERT.
HARVESTER.

No. 183,801.

Patented Oct. 31, 1876.

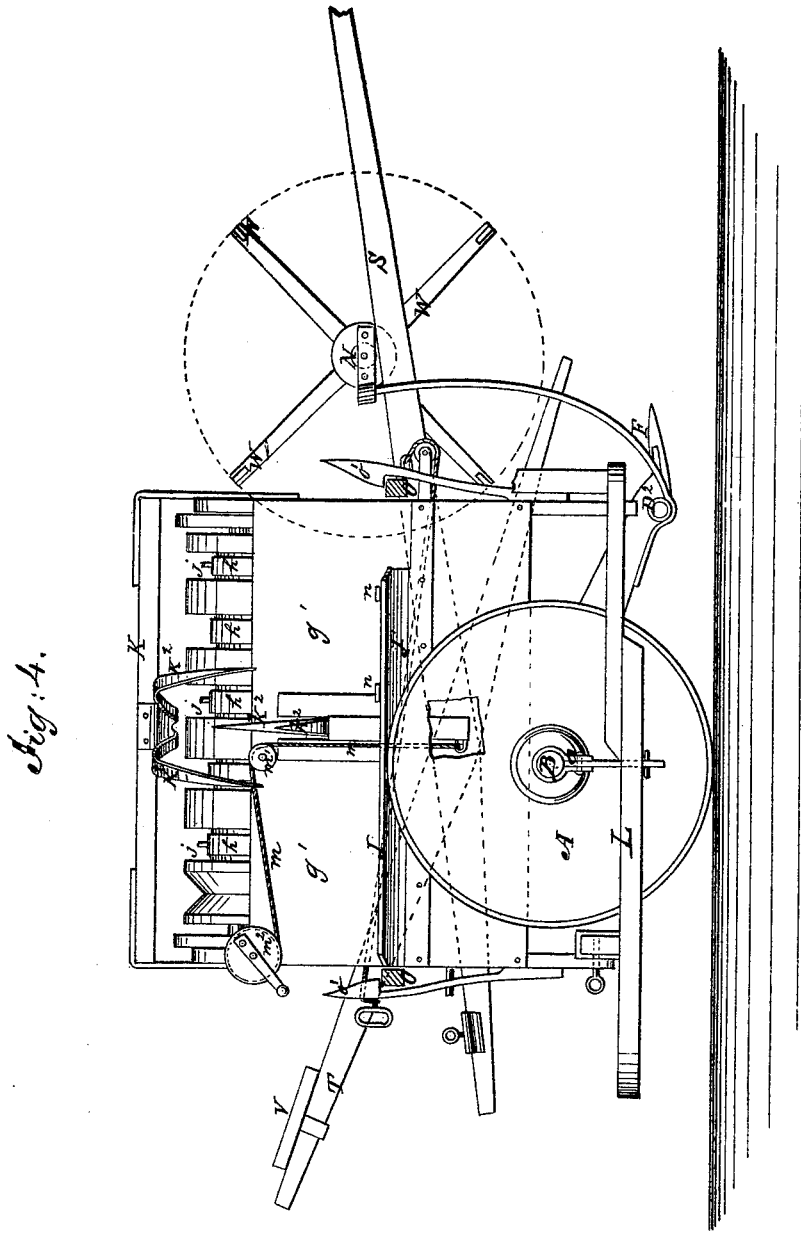

Fig. 4.

Witnesses:
H. C. Patterson
A. J. Wood

Fig. 6.

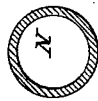

Fig. 5.



Inventor:
 Ezra Emmert
E. J. [Signature]

Atty

UNITED STATES PATENT OFFICE.

EZRA EMMERT, OF HARMON, ILLINOIS.

IMPROVEMENT IN HARVESTERS.

Specification forming part of Letters Patent No. 133,301, dated October 31, 1876; application filed March 4, 1875.

To all whom it may concern:

Be it known that I, EZRA EMMERT, of Harmon, in the county of Lee and State of Illinois, have invented a new and useful Improvement in Combined Harvesters and Mowers; and that the following is a full, clear, and exact description of the same, reference being had to the accompanying drawings, and to the letters of reference marked thereon, making a part of this specification.

This invention is in the nature of an improvement in a combined harvester and mower; and this invention consists in a harvesting-machine provided with mechanism for elevating the grain to a binding device, the several parts co-operating and being adjustable relatively to each other, in the manner hereinafter specifically set forth.

In the accompanying sheets of drawings, Figure 1 is a plan or top view of my machine. Fig. 2 is a side view of the same, partly in section; Fig. 3, a detailed view, showing arrangement of pole, levers, cutter-bar, and driver's seat; Fig. 4, an end view; Fig. 5, a cross-section of finger-bar, and Fig. 6 a cross-section of reel-shaft.

Similar letters of reference indicate like parts in the several figures.

A is the driving-wheel of my combined harvester and mower, supported on a suitable axle, B. This axle rests in suitable bearings *a a'*, secured to the frame of the machine. Onto this axle are affixed a gear-wheel, B², and a ratchet-wheel, *b*, and secured to the frame-work of the machine, and resting in suitable bearings, are beveled gear-wheels *b*¹ *b*², so arranged that motion shall be imparted to them by a gear-wheel, *c*, which meshes into the gear-wheel B². Bolted or otherwise secured to the frame of the machine are supports C and D, these supports constituting the frame-work of the elevating and binding devices of the machine.

Secured within the framing-timber C² and the finger-bar D², by a hook and staple, *b*³, is a frame, E, which supports rollers *e e*². Around these rollers pass two separate and distinct endless belts, E² and G, each set of rollers having its separate belt. The innermost of the rollers *e* has affixed to the outer end of its shaft a pulley-wheel, *e*³, from which passes an

endless belt or chain to and around a pulley-wheel secured to the outer end of the shaft of the bevel-wheel *b*².

To the outer edge of the finger-bar D² is affixed a cutter-bar, F, in any ordinary manner. This cutter-bar has the ordinary reciprocating motion imparted to it by a lever, F², one end of which is pivoted to the outer end of the cutter-bar, and its other end secured to a connecting-rod, F³, the lever F² oscillating on a fixed pivot or fulcrum, *d*. The other end of the connecting-rod F³ is secured to a crank-pin, *f*, which is attached to the face of the pulley-wheel of gear-wheel *b*².

To the supports C and D of the elevating-belts are affixed plates *g g'*, the plate *g* being secured to the under side of the frame C, and the plate *g'* to the upper side or edge of the frame D. The lower end of the frame C has secured to it a roller, G', and the upper end of the frame-work C D has secured to it a roller, H, with a series of channels, *i*, formed in the surface thereof.

Passing around the roller G' and the roller H are a series of endless bands, *h*. These bands pass around the channels *i* in the roller H, and they are provided with a series of projections or cleats, *j*.

Secured to each side of the frame *c* are guides *j*². These guides support and retain in position the frame-work of a clamping device, I. This device is constructed with a curved plate on its lower side, with two arms, *k*, at right angles to the same, extending upward. These arms are provided with ratchet or saw teeth *l*, and their upper ends have affixed to them guide-pins *l*², which work into slots formed in spring guide-plates *l*³. To the face of the plate *g*¹, which is secured to the framing D, is affixed a platform or binders' table, J, at right angles to the same.

Secured to the face of the plate *g*¹, in suitable guides, is a sliding beam, *g*², to the upper end of which are affixed tines *k*². Immediately over these tines, and secured to a beam, K, are two other tines, K¹ K². From the lower end of the beam K passes a cord or chain, *m*. This cord passes around a pulley, *m*¹, and around a larger pulley, *m*², with a crank thereto attached. To the platform J are fastened projecting tines *n*. Affixed to the



if no provision were made, it would be carried upward and presented to the binders with the ends foremost, interfering materially with the binding process.

To obviate this, I divide the main carriers into two parts, as before stated, and as shown in Fig. 1, and marked E² and G. The carrier G passes with a greater degree of speed than does the carrier E², so that the butt-ends of the cut grain, which rest upon it, will be advanced faster than the heads of the grain, and will be carried to the binders evenly and parallel, in which position they can be the more readily bound. The additional speed to be given to one of these carriers may be imparted to it in any desirable way.

As the grain passes up to the elevating-bands *h* it passes beneath the clamping device I, which follows it to some extent as it passes upward, (since this device has a reciprocating motion, as before stated,) and the grain is prevented from working its way back onto the main carriers by reason of the ratchet-teeth *l*, secured to the uprights *k k* of the clamping device, and the cleats *j* of the carriers. These ratchet-teeth and cleats not only prevent the grain from falling back but facilitate its advance.

To prevent the shrinking and stretching of the canvas from which the carriers are made, and also to preserve them from decay, I charge the canvas with oil, paint, shellac, or other waterproof and preserving substance, which adds not only to the preservation of the carrying-cloth, but results in a great saving of time, since the annoyance and loss from the shrinking and loosening of the carriers are well known to users of harvesting devices, and besides it avoids the necessity of cutting and tightening the bands.

As the grain is carried upward by the elevating-bands *h* the springs *B*, (which also act as guides for the uprights *k k* of the clamping device I,) hold the grain in position, when the discharge is cut off by the binders. The channels *i* in the roller H are made of sufficient depth to cause the grain to be disengaged from the cleats or teeth *j* on the elevating-bands *h*, since the collars formed between each groove project sufficiently to lift the grain from the cleats as it passes over the roller. As the grain passes over the roller H it is compressed between the tines K¹ K² and the tines *k*² by the driver or attendant standing on the platform L, who, by means of the wheel *m*², forces up the tines *k*², which hold the grain in position until it is bound.

The driver's seat V may be removed, when one lever may be used for holding the machine in position, while the front end of the other lever can be adjusted higher or lower in the ratchet *w* of the guard Y, and the fulcrum-pin *d*¹, which holds the tongue in position, may be withdrawn, and the cutter-bar be in this way held to any position desired by placing a pin through the holes in the guide *t*, or,

when the machine is to be used simply for mowing, this confining-pin may be removed entirely, when the pole may move freely up and down, thereby permitting the cutter-bar to adjust itself automatically to the inequalities of the surface of the ground over which it passes. The driver's seat V may also be moved to or from the ends of the levers T which support it, so that the weight of the driver will balance the cutter-bar, or rather so that the bar may be a little heavier than the driver. The weight of the driver in this way, or rather a slight change in his position, will facilitate the raising or lowering of the cutter-bar to pass an obstruction, as before stated.

The carriers E² and G and the frame to which they are secured are confined to the frame of the machine by means of a hook-and-eye bolt, *b*³, so that they may be detached without loss of time from the machine whenever it is desired to do so, and without the necessity of using a wrench, so that the machine may be converted into a mower at once by removing these carriers and the elevating-bands *h* and the frames thereof.

If it is desired that the machine be used for cutting barley or flax, it may be transformed into a machine for such purpose by simply removing the elevating-bands and their supporting-frames, which is done by withdrawing the holding-bolts, which confine the frames thereof to the frames of the machine, and as the machine proceeds to cut the barley the barley will run off in rows at the side of the machine, or it may fall onto the carriers, which will deliver the cut grain at the end thereof.

The advantages of operating the cutter-bar from the outer or grain end of the same are that the operating parts may be readily repaired in case of accident, they may be simplified in their construction, and a more positive action of the sickle-bar is insured.

The arms of the reel I design to secure to the reel-shaft by cast-iron centers W, held in place by set-screws on the shaft, the arms to be adjusted to the centers by bolts, and this angle can be changed at pleasure, according to the way the grain leans.

It may be found advisable at times not to use the clamping device for compressing the bundle. In that case the device may be removed from the machine and the binding performed as in ordinary harvesters.

The uneven speed of the carriers will, when harvesting barley or flax, cause the grain or flax to be deposited in straight rows, the stems and heads lying parallel.

The carriers may have their positions reversed so as to bring the slowest one in front, which will cause the grain to be given off in a continuous swath.

Having thus described the construction and operation of my combined harvester and mower, what I claim as new, and desire to secure by Letters Patent, is—

1. The frame-work supporting the elevating

belts and roller detachably connected to the main frame of the machine, substantially as and for the purpose described.

2. The combination of the pole, provided at its rear extension with the foot-rest, the seat-support and seat, guard Y, and cutting apparatus, constructed and arranged substantially as shown and described.

3. The reciprocating clamping device or float, provided with ratchet-teeth on its inner face, in combination with the elevating-belts,

substantially as and for the purpose described.

4. The fixed tines K^1 K^2 , and vertically-reciprocating tines k^2 k^2 , in combination with the operating cord m and drum m^2 , constructed and arranged substantially as described.

EZRA EMMERT.

Witnesses:

HARVEY MORGAN,
JAS. M. SWAN.