

D. W. KELLOGG.

PUMP CYLINDER AND VALVE.

No. 183,806.

Patented Oct. 31, 1876.

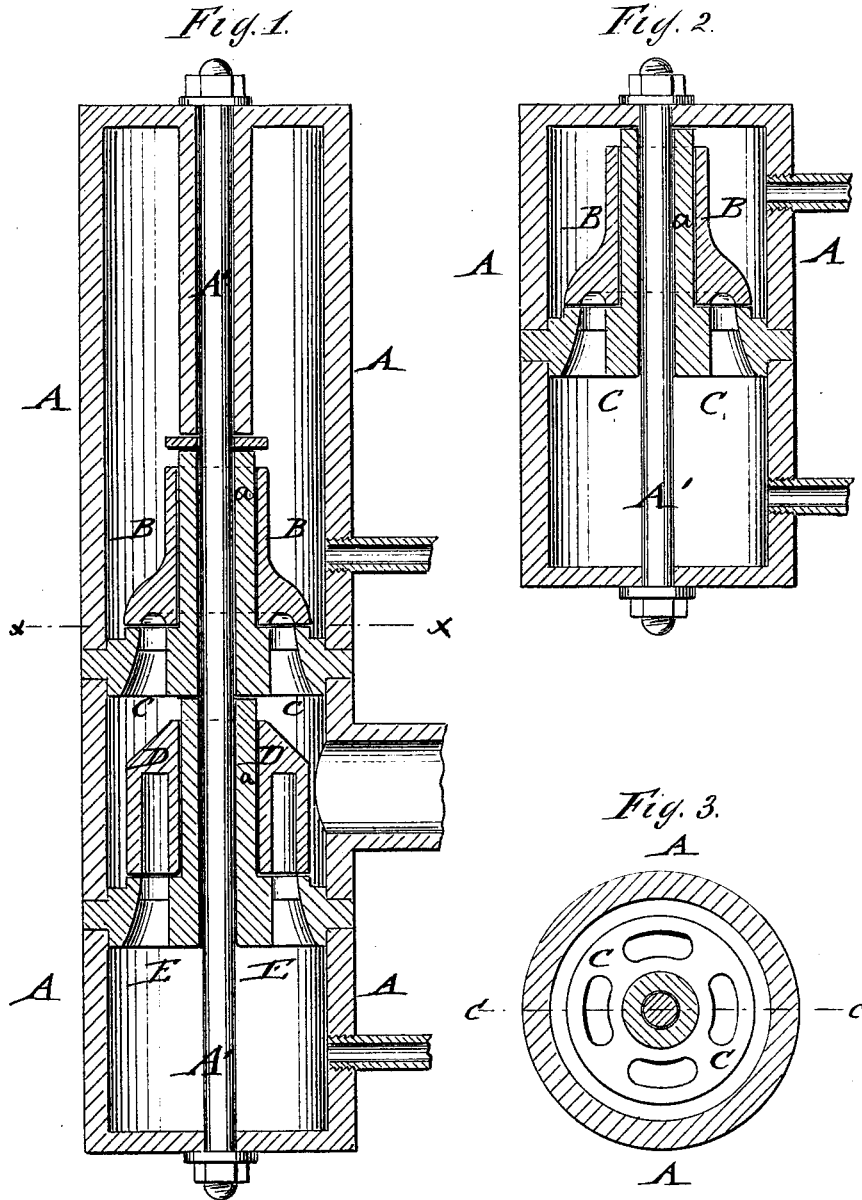

WITNESSES:

E. Wolff
John Goethals

INVENTOR:

D. W. Kellogg
BY *Munn & Co.*
ATTORNEYS.

UNITED STATES PATENT OFFICE.

DAN W. KELLOGG, OF BATTLE CREEK, MICHIGAN.

IMPROVEMENT IN PUMP CYLINDERS AND VALVES.

Specification forming part of Letters Patent No. **183,806**, dated October 31, 1876; application filed June 6, 1876.

To all whom it may concern :

Be it known that I, DAN W. KELLOGG, of Battle Creek, in the county of Calhoun and State of Michigan, have invented a new and Improved Pump, of which the following is a specification:

In the accompanying drawing, Figure 1 represents a vertical central section of my improved pump on line *c c*, Fig. 3; Fig. 2, a vertical central section of a check-valve of similar construction; and Fig. 3, a horizontal section of the pump or valve on line *x x*, Fig. 1.

Similar letters of reference indicate corresponding parts.

The invention has reference to an improved construction of valves and pumps for steam-engines, and especially locomotives, that may be readily taken to pieces to be cleaned and put together at a great saving of time, and without stopping the engine; and the invention consists of a pump or valve made of detachable sections, connected by a single center bolt passing through center of valve-seats. The valves are guided along the stems of the valve-seats, and the faces of valve-seats and sections ground together to make true and square joints.

In the drawing, A represents the casing or cylinder of the pump or valve, which is made of sections that are separated by the valve-seats C, the meeting edges or faces of the sections and valve-seats being ground up to form perfectly true and tight joints. The sections forming the pump or valve—namely, the usual air-chamber, pump-chamber, and lower valve-chamber—are connected by one single bolt, A', that passes through the center of the valve-seats B, being tightly held by end washers and screw-nuts. This one connection admits of ready detaching and replacing of the lower

valve-chamber, for cleaning without stopping the engine, which saves considerable time and delay, as compared to the present fastening with two or more bolts. The valves B and D slide on hollow stems *a* of the valve-seat C and E, being stopped either by contact with the next valve-seat, or by the head of pump or valve casing, or by collar, or sleeve, or bolt.

The valve and valve-seats are preferably made of brass, the pump or valve sections being made of iron.

The stem of lower valve-seat E comes in contact with under side of upper valve-seat C, and is ground to bear intimately thereon, to prevent leakage of water around bolt. The stem of upper valve comes in contact with a collar, or sleeve, or bolt, or the head of valve, to prevent leakage. The valves slide readily along the stems, following the suction and force action of the plunger, drawing in the water through an entrance-pipe of the lower chamber, and forcing it out through a discharge-pipe of the air-chamber.

The connection of the parts of the pump and the working of the valves are very reliable, and especially adapted for portable and locomotive engines.

Having thus described my invention, I claim as new and desire to secure by Letters Patent—

The combination of sectional cylinder A, with valve-seats at the junction of the sections, a valve for each seat, and a single bolt passing centrally through sections, seats, and valves, substantially as and for the purpose specified.

DAN W. KELLOGG.

Witnesses:

MOSES B. RUSSELL,
FRED. M. WADLEIGH.