

J. TINGLEY.

HEELS FOR BOOTS AND SHOES.

No. 183,826.

Patented Oct. 31, 1876.

Fig. 1.

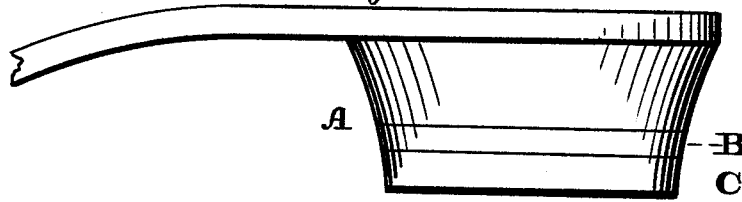

Fig. 2.

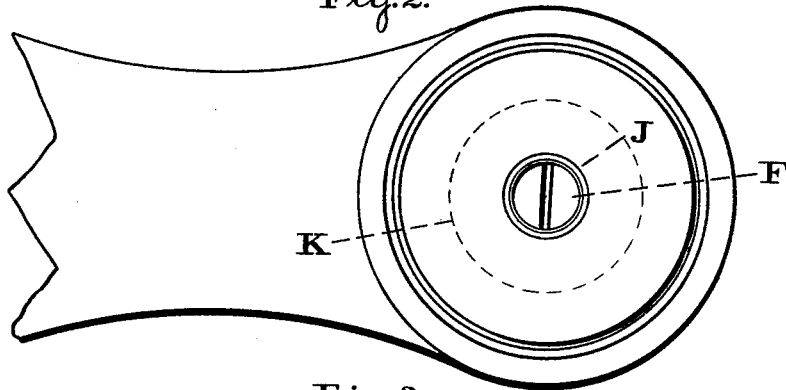

Fig. 3.

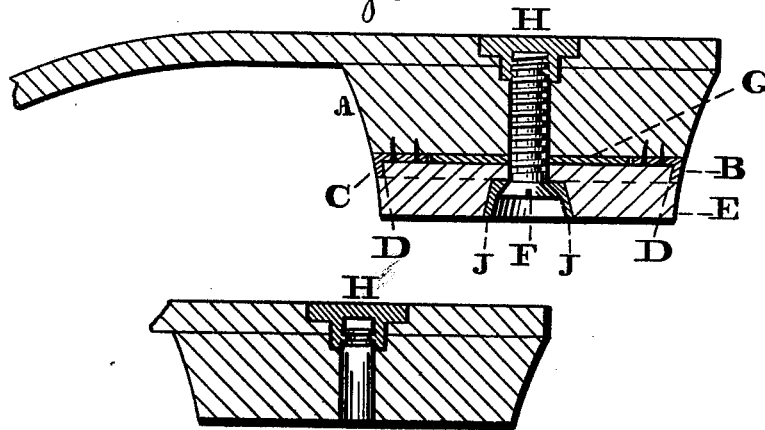
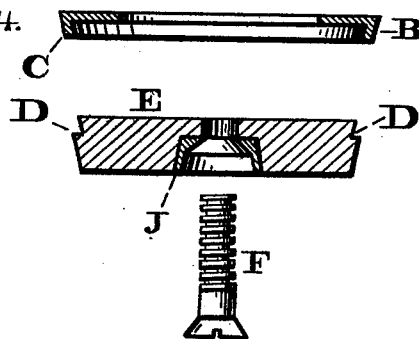

Fig. 4.



Witnesses:
John Diederheim
A. P. Grant.

Inventor:
John Tingley

UNITED STATES PATENT OFFICE.

JOHN TINGLEY, OF PHILADELPHIA, PENNSYLVANIA.

IMPROVEMENT IN HEELS FOR BOOTS AND SHOES.

Specification forming part of Letters Patent No. 183,826, dated October 31, 1876; application filed January 6, 1876.

To all whom it may concern:

Be it known that I, JOHN TINGLEY, of the city and county of Philadelphia, and State of Pennsylvania, have invented new and useful Improvements in Boot and Shoe Heels; and I do hereby declare the following to be a clear and exact description of the nature thereof, sufficient to enable others skilled in the art to which my invention appertains to fully understand, make, and use the same, reference being had to the accompanying drawings, making part of this specification, in which—

Figure 1 is a side view of a heel embodying my invention. Fig. 2 is a bottom view thereof. Fig. 3 is a longitudinal vertical section thereof. Fig. 4 is a similar view, the parts being separated.

Similar letters of reference indicate corresponding parts in the several figures.

My invention consists of an annulus formed with a downwardly projecting flange, and fixed to the upper part of the heel, in combination with a rotary and detachable tread or lift, and with a screw-nut embedded in the sole, and a recessed thimble for the head of the screw, whereby the said tread will be confined and guided in its motions and held steady in position, and lateral strain on the central screw is prevented.

Referring to the drawings, A represents the upper portion of the heel, which is fixed to the insole. B represents an annulus or ring, which is nailed or firmly secured to the part A, and from the under side of which there projects downwardly a flange, D. E represents the tread, on the upper edge of which is a recess, E, which forms a shoulder, against which is fitted the flange D of the annulus B. In the tread there is secured a recessed thimble, J, through which is passed a screw, F, which engages with a nut, H, fixed to the in-

sole or upper part of the heel, whereby the several parts of the heel will be firmly connected.

It will be seen that the tread has a rotary motion, and as it wears it may be turned, so as to shift the locality of the wearing-surface, whereby the heel may always be kept level, and when the tread is fully worn it may be readily removed and a new tread substituted therefor.

It will also be seen that the immovable flange of the fixed annulus circumscribes the upper edge of the rotary tread, and serves to confine the tread within the flange, and prevent lateral strain on the central screw F, when the boot or shoe is in service, and also to guide the tread while being rotated or shifted.

I am aware that a rotary and detachable tread is secured to the fixed portion of the heel by a central screw. I am also aware that a flanged plate is secured to, and moves with, the rotary tread; but in such construction the flange does not act as a guide for the tread, or prevent lateral strain on the central screw. Such features I do not claim; but,

Having described my invention, what I do claim, and desire to secure by Letters Patent, is—

The annulus B, formed with a downwardly-projecting flange, C, and immovably connected to the stationary part A of the heel, in combination with the rotary tread or lift E, having a recess, D, on its upper edge, and with the screw F, fixed upper nut H, embedded in the sole, and recessed thimble J, substantially as and for the purpose set forth.

JOHN TINGLEY.

Witnesses:

JOHN A. WIEDERSHEIM,
H. E. HINDMARSH.