

VAN H. HIGGINS.

WATER-METER.

No. 183,850.

Patented Oct. 31, 1876.

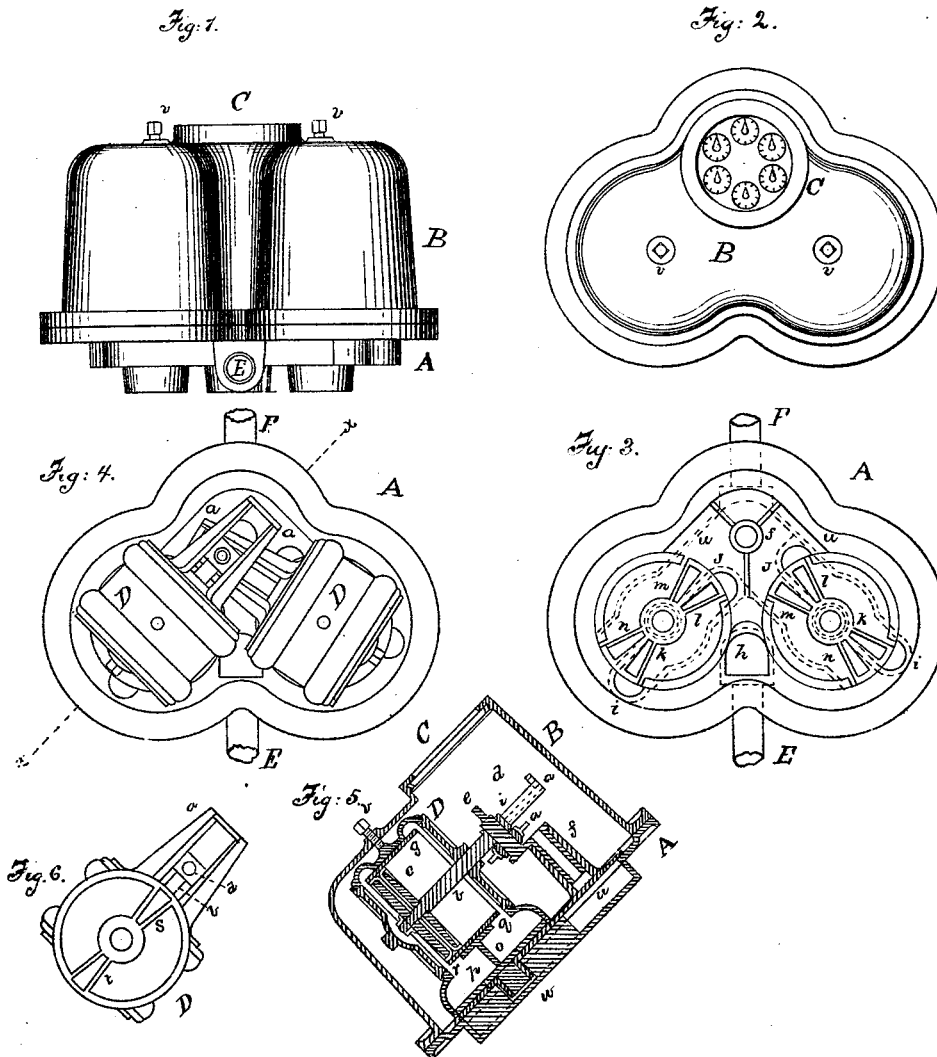

WITNESSES:

C. W. Marsh
O. V. Bond -

INVENTOR:

Van H. Higgins.
By West & Bond.
Atty.

UNITED STATES PATENT OFFICE.

VAN H. HIGGINS, OF CHICAGO, ILLINOIS.

IMPROVEMENT IN WATER-METERS.

Specification forming part of Letters Patent No. **183,850**, dated October 31, 1876; application filed December 13, 1875.

To all whom it may concern:

Be it known that I, VAN H. HIGGINS, of the city of Chicago, Cook county, State of Illinois, have invented new and useful Improvements in Water-Meters, of which the following is a full description, reference being had to the accompanying drawings, in which—

Figure 1 is an elevation; Fig. 2, a top or plan view; Fig. 4, a plan view with the case removed; Fig. 3, a plan view of the base-plate; Fig. 5, a section on line *xx* of Fig. 4; Fig. 6, a bottom view of the cylinder-case.

The nature of my invention consists in providing a water-meter with two oscillating cylinders arranged to operate with a single crank-shaft; in arranging the cylinders within a case or shell which may be filled with water; in the arrangement of the inlet and exhaust openings or ports; and in the construction and operation of the several parts, and combination of parts, hereinafter described and claimed as new.

In the drawings, A represents the base-plate; B, the cap or cover; C, the register; D, the cylinders or cylinder-case; E, the inlet, and F the outlet, pipes or openings; *a*, the guiding and supporting arms for the piston-rod; *b*, the piston-rod; *c*, the piston-head; *d*, the collar or opening at the end of the piston-rod, through which the crank passes; *e*, the crank; *f*, the crank-shaft and support; *g*, the cylinder; *h*, the inlet-opening into the case B; *i j*, the inlet-openings; *k l*, the inlet-ports into cylinders D; *m n*, the outlet-ports from cylinders D; *o p*, the openings or chambers in the base of the cylinder-case D; *q r*, the cylinder-ports; *s t*, the opening or ports through the lower base-plate of the case D; *u*, the outlet or exhaust chamber; *v*, the screws for keeping the cylinder-case D in position while the meter is being handled or set; *w*, the shaft or pinion upon which the case D oscillates.

The base-plate A is made as shown at Fig. 3, and is provided with the inlet and outlet pipes E F, and also with the lower inlet and exhaust ports, and for the purpose of giving the wearing-parts a proper finish, they are brought to a level with the top of said plate. If desired, however, one side or section of the ports may be made lower than the other, in

order to give the piston a proper connection with the crank; but I prefer to make them on a level, and to arrange for making the proper connection with the crank, by making one of the cylinder-cases, D, a little higher, by giving it a higher base, which works equally well, and makes less labor in fitting. Each case D is made with a base having two openings or chambers, *o p*, and for convenience a separate cylinder, *g*, is inserted. This, however, may be made a part of the case, and be turned or bored out in the usual or well-known manner. The heads of the cylinder are screwed in, or otherwise inserted, as may be found most convenient, but so as to leave a space for the inflow and exhaustion of the water, as shown at Fig. 5. This space, however, need not extend entirely around; but I prefer that it should extend about one-third around, so as to permit of a free escape of any dirt or sediment that may find its way into the cylinder.

The piston-rod *b* is provided at its inner end with a head, *c*, made in two sections or parts, as shown, between which parts strips of leather or other suitable packing material are inserted; and, to guard against leakage, it will be advisable, when leather is used, to put in two pieces, which turn outward in opposite directions at the periphery, so as to form a sort of double packing, and prevent leakage without undue friction. The outer end of the piston-rod is provided with a head, *d*, which slides in suitable grooves in the guide-frame *a*, which not only steadies the piston, but also relieves it from friction or wear on the cylinder-head when oscillated, by reason of its attachment to the crank *e*. This gives an easy and durable movement to the piston. The piston-rods *b* are both attached to the crank *e*, as shown at Fig. 4.

In order to give the best movement the two cylinders should be placed at right angles with each other, but a greater or less angle of a few degrees will not prevent its operation.

The crank *e* is set in a suitable bearing, *f*, and its upper end is made sufficiently long to connect or engage with an arm which moves the gearing of the registering device, which is not shown, as I propose using any of the

ordinary registering devices now in the market, no special one being required.

When the parts are in the position shown in Fig. 4, the case or cover B is placed over and bolted, or otherwise suitably connected with the base A. The joint will be packed so as to make it water-tight.

In operation, the water flows in at the pipe E, and enters into the case B through the opening *h*, and fills the entire case. The openings or ports *k l* communicate with the water in the case B, as shown at Fig. 3, and receive the water therefrom. From thence the water passes into the chambers or openings *o p* in the base of the case D, and from them into the cylinder D, and from the cylinder out through the ports *m n* to the outlet or pipe F.

The openings in the base-plate A, as will be seen, are double, while they are single in the case D. It will, therefore, be seen that in each oscillation of the case D the openings *s t*, with the base, will alternately act as inlet-ports and exhaust-ports, according to the movement. By this arrangement a continuous stream or flow of water is maintained, without any beating or intermittent flow.

By arranging the two cylinder-cases to operate upon the same crank *e*, there are no dead-points in the movement, and the one is so timed with the other that there is no interruption in the flow of the water.

By allowing the water to entirely fill the case B, I avoid all stuffing-boxes and packing, except as to the piston-head, and the pressure of the water in the case keeps the cylinders D down upon the base-plate A, so that I am enabled to dispense with attachments or devices for that purpose. A simple pinion or stem, W, to keep them in position laterally, is all that is required, and as the wearing-surfaces fit each other, the meter will run for a very long time without any fitting or repairs.

Where the pressure of the water is heavy or strong, it will be desirable to cut away a portion of the metal of the base-plate A, or bottom of the cylinder-case D, so as to let the water in between them, and by cutting out, more or less, the pressure of the cylinders D upon their bases may be adjusted to any required degree.

By placing strong plate-glass over the dials, the water may be also let into them, so as to obviate the necessity of any stuffing-boxes or

packing between the case B and the dial-movements. This makes a complete and efficient meter, as I have found from the actual use of such meter.

By discharging the water downward the cylinders are at all times kept free from sand, grit, or other sediment.

By attaching or connecting all of the moving parts shown with the base A, the case or cover B can be removed without disturbing any of the attachments, or in any way interfering with them.

The screws *v*, after the meter is set, may be left bearing on the cylinder, or they may be unscrewed, as desired.

What I claim as new, and desire to secure by Letters Patent, is as follows:

1. The combination of the base A and case B with the horizontal cylinders or cylinder-cases D, seated upon the base for bringing the water-pressure to act with the weight of the cylinders to avoid packing, and to compensate for the wearing of the parts, substantially as specified.

2. The combination of the two cylinders D, at, or nearly at, right angles with each other, and having their pistons connected together at their outer ends, for preventing dead-points, assisting each other in their oscillations, and equalizing the flow of water, substantially as set forth.

3. The combination of the openings *i j*, and ports or openings *k, l, m, n* of the base A, with the ports or openings *s t*, and cylinders D, substantially as specified.

4. The combination of the chambers or opening *o p*, with the openings *q r* of the cylinder, and the discharging-chamber *u* for discharging the water downward, substantially as set forth.

5. The combination of the base A, cap or case B, with the cylinders D, constructed and operating as specified, with the single crank *e*, substantially as and for the purposes specified.

6. The guides *a*, in combination with the cylinders D, piston-rods *b*, and heads *d*, substantially as and for the purpose specified.

VAN H. HIGGINS.

Witnesses:

L. L. BOND,
O. W. BOND.