

M. M. RHODES.

MACHINE FOR FINISHING BUTTONS.

No. 183,866.

Patented Oct. 31, 1876.

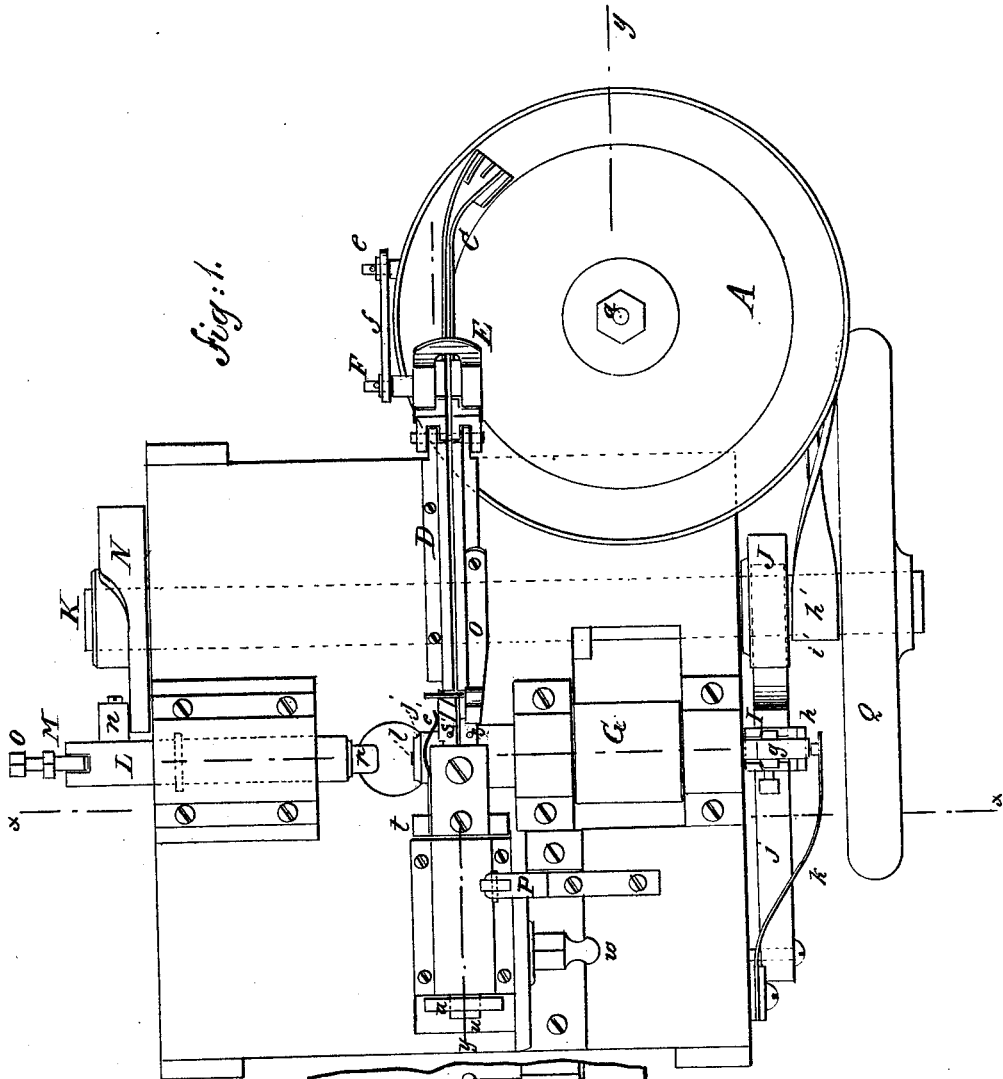

Fig. 1.

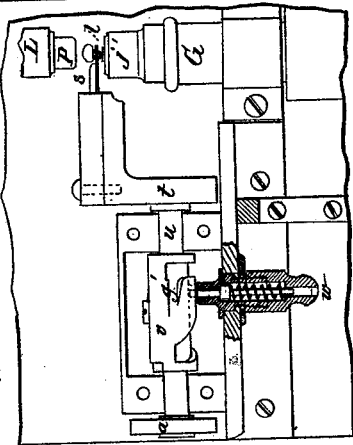

Fig. 2.

WITNESSES:

Chas. F. Fida
John Goodrich

INVENTOR:

M. M. Rhodes

BY

[Signature]

ATTORNEYS.

M. M. RHODES.

MACHINE FOR FINISHING BUTTONS.

No. 183,866.

Patented Oct. 31, 1876.

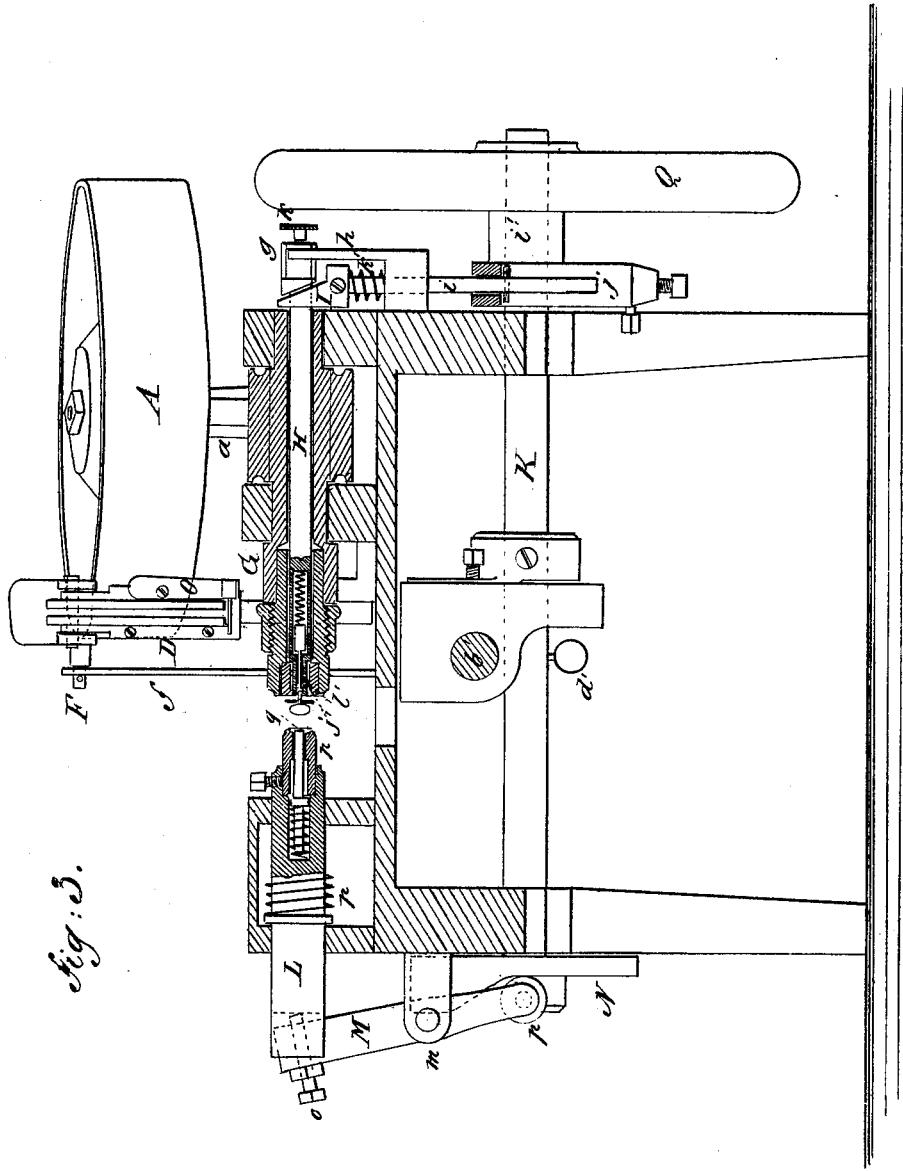

Fig. 3.

WITNESSES:

Chas. Kida
John Goethals

INVENTOR:

M. M. Rhodes

BY

Munnell

ATTORNEYS.

M. M. RHODES.

MACHINE FOR FINISHING BUTTONS.

No. 183,866.

Patented Oct. 31, 1876.

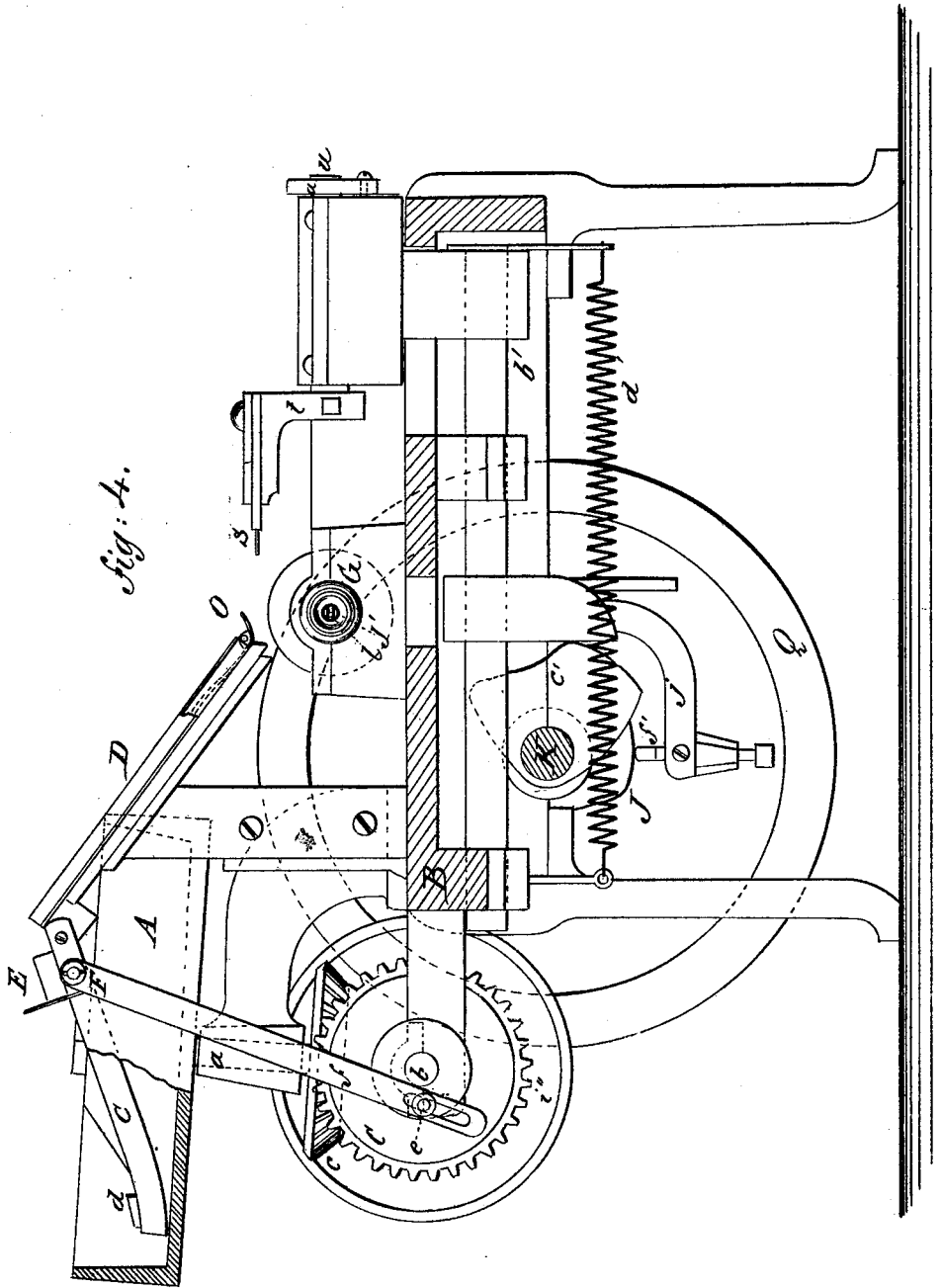

WITNESSES:

Chas. Nida
John Goetz

INVENTOR:

M. M. Rhodes

BY

Munnell

ATTORNEYS.

UNITED STATES PATENT OFFICE.

MARCUS M. RHODES, OF TAUNTON, MASSACHUSETTS, ASSIGNOR TO M. M. RHODES & SONS, OF SAME PLACE.

IMPROVEMENT IN MACHINES FOR FINISHING BUTTONS.

Specification forming part of Letters Patent No. 183,866, dated October 31, 1876; application filed August 7, 1876.

To all whom it may concern:

Be it known that I, MARCUS M. RHODES, of Taunton, in the county of Bristol and State of Massachusetts, have invented a new and Improved Button-Finishing Machine, of which the following is a specification:

Figure 1 is a plan view. Fig. 2 is a detail view of the nipper-actuating mechanism. Fig. 3 is a side elevation, in section, on line *x x* in Fig. 1. Fig. 4 is a section on line *y y* in Fig. 1.

My invention relates to machinery for finishing buttons; and it consists of a combination of a feeding and holding device with a revolving mandrel carrying a cutter or finisher. The whole is arranged so that buttons that are placed in bulk in a receptacle in the machine are automatically placed in a holding device to be operated on by the rotating cutter or finishing-tool.

The object of my invention is to rapidly finish the edges of buttons. The machine is more particularly adapted to finishing *papier-maché* shoe-buttons.

A is a receptacle for buttons, that is slightly inclined toward the body of the machine. It has a raised or conical bottom, and is supported on the shaft *a*, which takes its motion from the shaft *b* through the miter-wheels *c c*. The shafts *a* and *b* are placed in suitable supports, attached to the main frame B of the machine. C is a movable chute, hinged to a stationary chute, D, and provided with a fan-shaped end, having several short channels that terminate in the main channel of the chute. It is also provided with a fender, *d*, for guiding the buttons into the channels. E is a gate, placed over the chute C, that will allow only such buttons to pass it as are of the proper size. F is a wrist-pin, attached to the chute C, that is connected to the crank *e* on the shaft *b* by the rod *f*. The stationary chute D is attached by a standard to the main frame of the machine. G is a hollow mandrel, that is supported in suitable boxes on the main frame B, and receives its motion from any convenient power. It is provided with either a plain die of the required form, or with a cutting-head, *j'*. A holding-spindle, H, runs through the mandrel G, and is prevented from turning by a square head, *g*, which moves in

a guide, *h*. I is a forked wedge that embraces the spindle H, and, when forced upward by the spring *k'*, it engages with the head *g*. This wedge is connected by a rod, *i*, to a lever, *j*, that is moved by a cam, J, on the main shaft K. The lever *j* is provided with an adjustable follower, *j'*, that regulates the motion of the wedge I. A spring, *k'*, is attached to the frame B, and presses on the end of the spindle H. The end of the spindle that is opposite the head *g* is slotted, and provided with a spring-follower, *l*. L is the head-spindle, which moves in a guide attached to the main frame of the machine. M is a lever, resting in a slot in the end of the spindle L, and is pivoted at *m*, and carries the roller *n* that engages with the cam N on the end of the main shaft. An adjusting-screw, *o*, passes through the upper end of the lever M, and bears against the end of the spindle L. A die, *p*, having a concave end, and a spring-center, *q*, is placed in the end of the spindle L. A coil-spring, *r*, surrounds the spindle L, and throws it back against the lever M. S S' are carrying-nippers, that are supported on a rocking arm, *t*, that is carried by a shaft, *u*, upon which a spiral cam, *v*, is placed, throwing the arm *t* over as it is drawn from the slide D, but allowing a spring, *a'*, to throw the arm *t* into a vertical position as the cam passes the bolt *w*. The supports for shaft *u* are attached to a sliding rod, *b'*, which is moved by a cam, *c'*, on the main shaft, which engages with tappet on the sliding rod. A coil-spring, *d'*, having one end attached to the sliding rod and the other attached to the main frame, keeps the tappet against the cam. O is a spring stop-pin, which retains the buttons in the chute D, except when it is raised by the nippers S S'.

One jaw, S, of the nippers is fixed. The other, S', is capable of lateral motion, so that a beveled elongation of jaws, engaging with a beveled end of the chute D, opens the jaws to receive the buttons. A spring, *e'*, bears against the movable jaw.

P is a buffer, against which the arm *t* strikes as the spring *a* throws it into a vertical position. As the nippers are moved toward the chute D, the spring-bolt slips over the inclined part *g'* of the cam *v*, and does not en-

gage with the cam until the nippers are on the return stroke. The shaft *b* receives its motion from the shaft *K*, through the belt *h'*, which runs on the pulleys *i' i''*. The shaft *K* is provided with a balance-wheel, *Q*, and takes its motion from any convenient power.

The operation of my machine may be described as follows: The buttons, with unfinished edges, are put into the receptacle *A*, and picked up by the fan-shaped end of the hinged chute *C*, as the receptacle *A* slowly revolves, the eyes being forced into the slot in the slide. At intervals the chute *C* is raised by the crank *e* working in a slot in the lower end of the connecting-rod *f*, and such buttons as will pass the gate *E* are delivered into the fixed chute *D*. The said slide is furnished at its lower end with a spring stop-pin, *O* which prevents the buttons from passing-out until the stop-pin is raised by the carrier-nippers *S S'*. The raising of the stop-pin by the carrier-nippers allows the first or lowest button to slide into them. As the carrier-nippers start away from the slide the stop-pin springs down, preventing another button from passing out of the slide. The jaws of the nippers also close down on the eye of the button. As the nippers are drawn away from the slide *D* by the cam *c'*, the spring-bolt *w*, by engaging with the cam *v*, brings the arm *t* over into the proper position to bring the eye of the button into the slotted end of the holding-spindle *H*. The nippers stop in this position long enough to allow the spindle *L* and the holding-spindle *H* to come together, taking the button by its eye and top, holding it securely.

The carrier-nippers are brought still farther forward, and disengaged from the button. At the end of the stroke the cam *v* passes the spring-bolt *w*, and regains its vertical position, ready to return to the slide and repeat the operation. The holding-spindle *H* is held in position by a stiff spring, *k*. The wedge *I* holds it back until the button is in the right position, when it is slipped down by the action of the cam *J*, allowing the spring *k* to force the spindle *H* forward upon the eye of the button. At the same time the cam *N* forces

the head-spindle *L* forward, engaging the top of the button. The button, being thus held between the spindles *L* and *H*, is carried, by the action of the cam *N*, into the shaving or polishing die *j'*, when the edge is finished to the desired shape. The cam operating the spindle *L* then releases it, and it is forced back by the spring *r*. The spindle *H* is also released, and is thrown forward by the spring *k*, and the button is thrown out finished.

Having thus described my invention, what I claim as new, and desire to secure by Letters Patent, is—

1. In a button-finish machine, a fan-shaped picking-up device, having the slots and fender, substantially as shown and described.
2. The combination of the hinged chute *c*, having a fan-shaped and slotted end, the gate *E*, connecting-rod *f*, crank *e*, and receptacle *A*, substantially as specified.
3. The combination of the chute *C* and *D*, and spring stop-pin *O*, substantially as specified.
4. The combination of the spring-nippers *s s'*, arm *t*, rocking shaft *u*, cam *v*, and spring-bolt *w*, substantially as shown and described.
5. The combination of the nippers *s s'*, and the beveled end of the slide *D*, substantially as specified.
6. The cam *c'*, constructed as specified, so that it will permit the carrying-nippers *s s* to pause while the button is being taken from them, in combination with the shaft *u*, arm *t*, and nippers *s s*, substantially as shown and described.
7. The combination of the mandrel *G*, spindle *H*, sliding wedge *I*, and spring *k*, substantially as specified.
8. The combination of the spindle *H*, wedge *I*, spring *k'*, rod *i*, lever *j*, and cam *J*, substantially as shown and described.
9. The combination of the buffer *P*, and arm *t*, as shown and described.

MARCUS M. RHODES.

Witnesses:

T. ALFRED MESSINGER,
FERDINAND S. READ.