

S. S. HULL.
 ROTARY-ENGINE.

No. 183,932.

Patented Oct. 31, 1876.

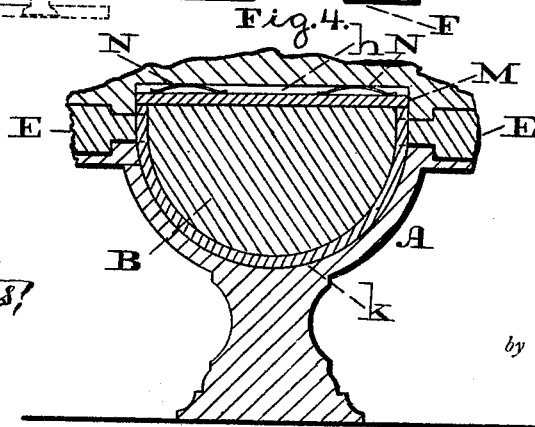
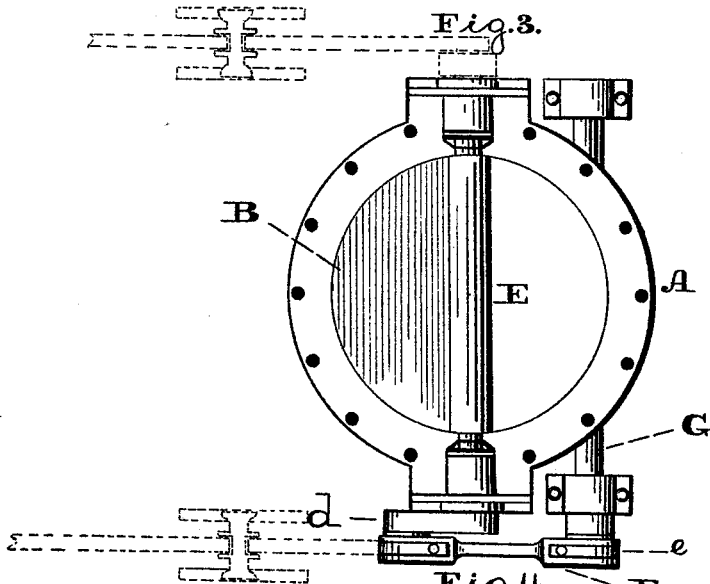
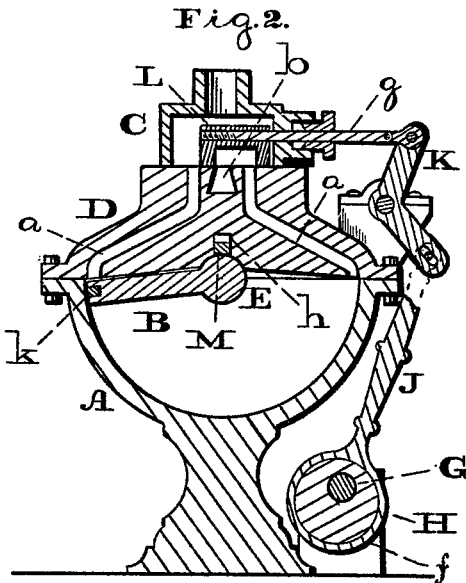
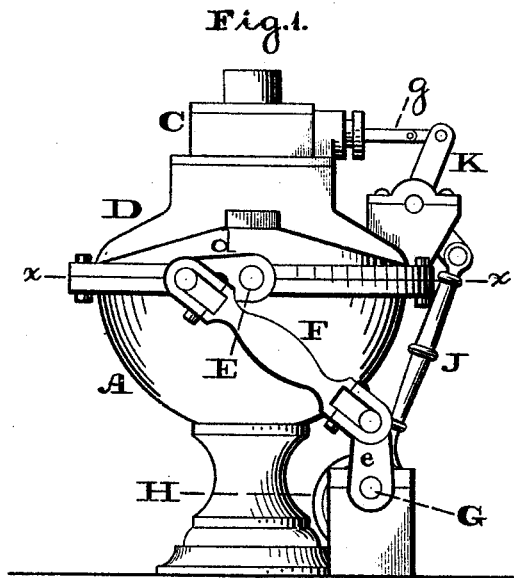

Witnesses:
 Lewis F. Brous,
 No. P. Grant.

Inventor:
 Saul S. Hull
 by
 John Diederheim
 Attorney.

UNITED STATES PATENT OFFICE.

SAMUEL S. HULL, OF PHILADELPHIA, PENNSYLVANIA, ASSIGNOR OF
ONE-HALF HIS RIGHT TO E. V. MACHETTE, OF SAME PLACE.

IMPROVEMENT IN ROTARY ENGINES.

Specification forming part of Letters Patent No. **183,932**, dated October 31, 1876; application filed
August 22, 1876.

To all whom it may concern:

Be it known that I, SAMUEL S. HULL, of the city and county of Philadelphia, and State of Pennsylvania, have invented a new and useful Improvement in Steam-Engines; and I do hereby declare the following to be a clear and exact description of the nature thereof, sufficient to enable others skilled in the art to which my invention appertains to fully understand, make, and use the same, reference being had to the accompanying drawings, making part of this specification, in which—

Figure 1 is a side elevation of the engine embodying my invention. Fig. 2 is a central vertical section thereof. Fig. 3 is a top or plan view of the portion below the line *x x*, Fig. 1. Fig. 4 is a central section of the lower portion of the engine, diametrically opposite to that shown in Fig. 2.

Similar letters of reference indicate corresponding parts in the several figures.

My invention consists of a reciprocating piston of semicircular form, which plays in a chamber of semi-spherical form, and imparts rotary reciprocating motion to the axis of the piston, which motion may be utilized for various purposes, said piston presenting its broad side for the impact of steam, whereby the engine will have great power, the piston having its axis on the semi-spherical chamber, and projecting at one or both ends from the sides of said chamber, for connection of a crank-arm or other attachment, whereby the motion of the piston may be utilized.

It further consists of a combination of parts to form an improvement in steam-engines.

Referring to the drawings, A represents a semi-spherical body or steam-chamber, within which is mounted the piston B, which is of semicircular shape, so that the broad face thereof will be presented for impact of steam, as most clearly seen in Fig. 3. Above the chamber A is mounted the valve-chamber C, and between the two chambers in the port-plate D, having live-steam ports *a* and exhaust-port *b*, which ports communicate with the chamber C and chamber A, the port-plate being supported on and firmly bolted to the

body A. E represents the axis of the piston B, and one end projects from the side of the steam-chamber A, and carries a crank-arm, *d*, to which is connected one end of a pitman, F, whose other end is connected to the crank-arm *e* of a rotary shaft, G, which is properly mounted adjacent to the steam-chamber. On the shaft G is keyed, or otherwise fitted, an eccentric, H, on which is fitted a strap, *f*, connected to an arm, J, which is pivoted to an elbow-lever, K, whose bearings are on standard rising from the chamber A or port D, or otherwise located. To one limb of the elbow-lever K is jointed the stem *g* of the slide L of the valve.

The operation is as follows: Steam will be admitted to the chamber C, and, passing through the uncovered part of the plate D, is impacted against the piston B, and it imparts motion thereto to the opposite side of the chamber A. Rocking motion is thus imparted to the axis E, and oscillating motion to the pitman F, which is so adjusted that rotary motion to the extent of a half-revolution will be imparted to the shaft G. Owing to the eccentric H and arm J, the elbow-lever K will be moved so as to shift the slide L of the valves, whereby the steam will be cut off from the previously-open port, and communication be made with the exhaust-port. Live steam then passes through the other port, *a*, now open, and the piston will receive its return motion, thus completing its stroke, and, by means of the crank-arm and pitman, the shaft G will complete its revolution.

The operation of the piston and movable parts of the engine will be repeated, and thus the shaft G will be continuously rotated, its power being available for various purposes. In some cases it may be desirable to have reciprocating sliding motions. To accomplish this an attachment will be made with the rocking crank-arm *d*, or the opposite end of the axis E, instead of with the rotary shaft G.

At the center of the base of the port-plate D there is formed a channel, *h*, which extends parallel with the axis E of the piston B, and in said channel *h* is fitted a packing, M, which

will be pressed against the face of the axis E by means of springs N, suitably located in the channel *h*, whereby there will be provided a steam-tight joint centrally of said axis E, or between the axis and the center of the port-plate D. The piston B will have a circumferential packing, *k*, for forming a tight joint with the contiguous face of the steam-chamber A.

It will be seen that the semicircular piston presents its broad face for the impact of steam, and the engine will have great power.

Having thus described my invention, what I claim as new, and desire to secure by Letters Patent, is—

1. The semi-spherical steam-chamber A, semicircular reciprocating piston B, and the projecting axis E, combined and operating substantially as and for the purpose set forth.

2. The semi-spherical steam-chamber A, semicircular reciprocating piston B, projecting axis E, and port-plate D, combined and operating substantially as and for the purpose set forth.

3. The semi-spherical steam-chamber A and semicircular piston B, in combination with the port-plate D and valve-chamber C, and with the pitman F, rotary shaft G, elbow-lever K, and slide-valve L, forming an improvement in steam-engines, substantially as set forth, and for the purpose described.

SAML. S. HULL.

Witnesses:

JOHN A. WIEDERSHEIM,
H. E. HINDMARSH.