

T. S. HUNTINGTON.

TAKE-UP MECHANISM FOR SEWING-MACHINES.

No. 183,933.

Patented Oct. 31, 1876.

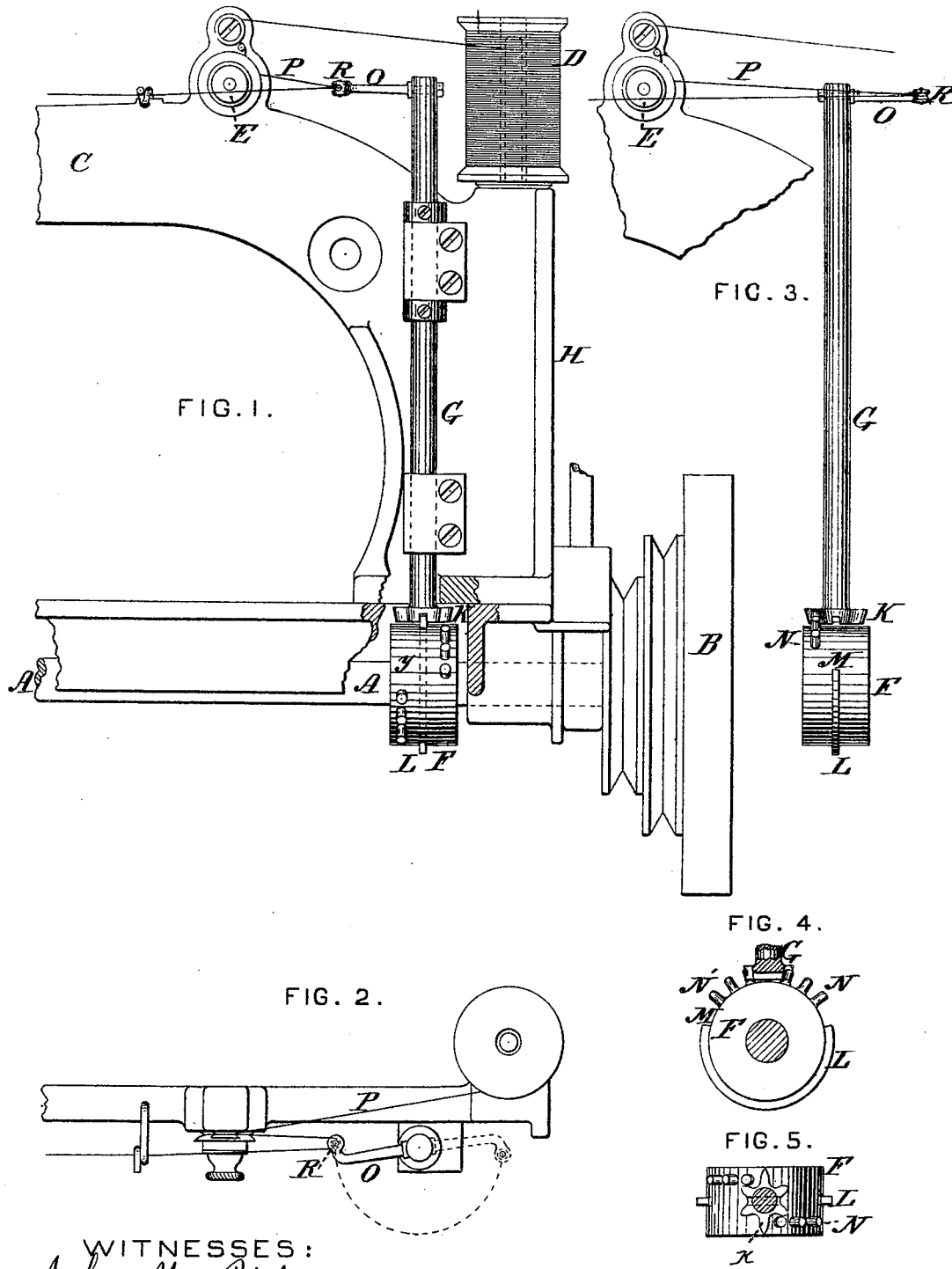

WITNESSES:
John M. Ripley
Boyd Elist

Thomas S. Huntington
INVENTOR.

UNITED STATES PATENT OFFICE.

THOMAS S. HUNTINGTON, OF NEW YORK, N. Y.

IMPROVEMENT IN TAKE-UP MECHANISMS FOR SEWING-MACHINES.

Specification forming part of Letters Patent No. **183,933**, dated October 31, 1876; application filed August 18, 1876.

To all whom it may concern:

Be it known that I, THOMAS S. HUNTINGTON, of the city, county, and State of New York, have invented a new and useful Improvement in Take-Up Motions for Sewing-Machines, which improvement is fully set forth in the following specification, reference being had to the accompanying drawings.

This invention pertains to that class of devices in connection with sewing-machines that is used for taking up the thread required for surrounding the spool or bobbin after the loop is formed, through which the spool or shuttle passes; and the invention consists in combining the take-up arm with a reciprocating device or mechanisms, whereby an oscillatory motion is imparted to the upper thread and in the arc of a semicircle, and so that the take-up will be varied in the proportion of the degree of oscillation of the take-up arm.

Figure 1 is a partial section and elevation of the devices as attached to sewing-machines. Fig. 2 is a plan as seen from above; and Fig. 3 shows the peculiar mechanism for accomplishing the operation of a take-up mechanism. Fig. 4 is an end view of the main shaft and an elevation of the pinion; and Fig. 5 is a top view of the same with a reciprocating pinion, shown in plan.

It has long been the desire of sewing-machine makers to obtain some method of taking up or controlling the slack portion of the thread required to surround the bobbin or shuttle without an extra quantity of thread, or causing any degree of what is termed "over throw," or more than the quantity actually required to perform perfect work. If a spring or a spring-arm is caused to vibrate to take up the slack of the thread, it is found that the extent of the vibration will overthrow an amount of the thread at each vibration to a degree that will be in proportion to the throw of the lever, and in proportion to the vibration of the lever; in other words, a thread at the other end of a vibrating arm in a sewing-machine take-up will be caused to travel farther at a high rate of speed than if permitted or caused to travel in the arc of a circle when the degree of throw is exactly equal to the radius of the arm or the diameter of the circle traversed by the take-up lever.

To understand the operation of this invention, A represents the main shaft of a sewing-machine, and B is the driving-wheel thereon. At C is shown a portion of the sewing-machine frame, and at D is represented the spool of thread, and at E is shown the tension devices for feeding and guiding the thread to the sewing mechanism. Upon the main shaft, as at F, there is mounted a cylinder to give motion to the take-up axis G, which is mounted in this case in bearings upon the rear of the yoke H of the machine. A peculiarity of the axis G is that upon its lower end there is mounted a pinion, as at K, (see Figs. 4 and 5,) which has a groove upon its lower side or face to fit upon a rib, as at L, on the cylinder F, and thereby holds the axis G in a proper working position during the rotation of the rib L. But the rib L is a segment of the circle surrounding the cylinder F, and is provided with recesses, as at M, by which the pinion L ceases to be guided by the said rib, and at that instant one of the teeth of the pinion engages with one of the teeth, as at N, on the cylinder F, and thereby causes the axis G to revolve in one direction, and thereby carries with it the take-up arm, as at O, mounted upon its upper end, and with it the thread, as at P, which passes through an eye in the extreme end of the arm or around a friction-roll, as at R, which may produce less friction than a plain eye. This movement of the take-up is shown by dotted line at Fig. 2, and the position of the pinion relatively to the cylinder F at the end of said motion is shown at Fig. 5, where it will be seen that a corresponding row of teeth, as at N', are mounted on the cylinder F in such position as to engage with the teeth of the pinion on the opposite side, and thereby cause a reverse movement of the take-up arm, which thereby instantly releases the thread, after having drawn up the stitch for another to be formed. But it is evident that, when such rapid vibrations are made as would be required in a practical sewing-machine, the take-up arm should be held accurately ready to perform its work at the proper time, and for this purpose the rib L is provided on the cylinder F to engage in the slot in the pinion K at the instant it leaves the last tooth, as at N', and thereby holds the take-up arm

in a fixed and proper position ready for action by a positive working mechanism, and which is operated directly from the main shaft of the machine.

The chief advantage of such a construction of the take-up devices in a sewing-machine is that if the thread is carried through a full semicircle, or nearly so, the action on the thread is gradual, beginning and ending slowly like the dead-points of a crank, and as it travels in the arc of a circle it is impossible to produce an overthrow after it passes the dead-points.

It is evident that, instead of a groove being formed in the pinion and a rib on the cylinder, the reverse may be done with equal advantage—that is, a rib may be formed on the pinion, and a groove in the cylinder—and it is also evident that the teeth may be those of a

bevel-gear, in place of pins and spur-teeth, as here shown.

I therefore claim—

1. In combination with the shaft G of the take-up arm, the pinion K and cylinder F, provided with a series of pins arranged to travel and gear with the pinion on opposite sides of the same for operating the take-up, substantially as described.

2. In combination with the shaft G and pinion K, the cylinder F, provided with a series of pins on opposite sides of the pinion arranged to gear with the same and the rib L, the whole arranged to operate substantially as described.

THOMAS S. HUNTINGTON.

Attest:

JOHN W. RIPLEY,
BOYD ELIOT.