

A. KAYSER.
PRESSURE VALVE.

No. 183,935.

Patented Oct. 31, 1876.

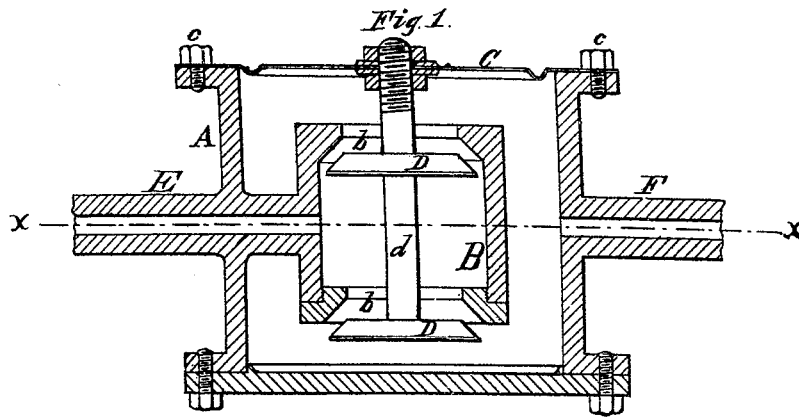

Fig. 1.

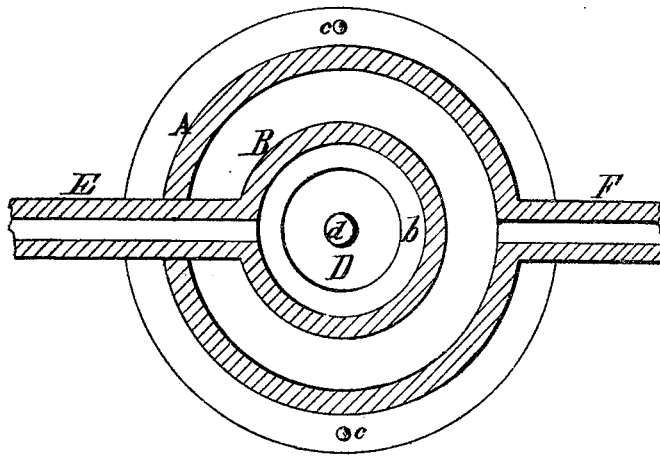

Fig. 2.

Chas. J. Buckheit...
George H. Sykes... } Witnesses

Adolph Kayser Inventor
By Edward Willison...
Attorney.

UNITED STATES PATENT OFFICE.

ADOLPH KAYSER, OF BUFFALO, NEW YORK, ASSIGNOR TO PASCAL P. PRATT, OF SAME PLACE.

IMPROVEMENT IN PRESSURE-VALVES.

Specification forming part of Letters Patent No. 183,935, dated October 31, 1876; application filed May 15, 1876.

To all whom it may concern:

Be it known that I, ADOLPH KAYSER, of the city of Buffalo, in the county of Erie and State of New York, have invented certain new and useful Improvements in Automatic Pressure-Valves, which improvements are fully set forth in the following specification, reference being had to the accompanying drawing.

My invention relates to that class of devices which are employed for regulating the outflow of gases under a uniform reduced pressure, and in which the valves controlling the flow of gas are opened and closed by an elastic diaphragm, exposed to the action of the gas under the reduced pressure.

My invention consists of the particular construction and arrangement of parts, as hereafter set forth.

In the accompanying drawing, Figure 1 is a vertical section of my improved valve. Fig. 2 is a horizontal section in line *x x*, Fig. 1.

Like letters of reference refer to like parts in each of the figures.

A represents the outer valve-chamber; B, a chamber of less size, arranged within the chamber A, and provided with two valve-seats, *b b*. C represents a flexible head, constructed of sheet metal, or other suitable material, and secured to the open end of the chamber A by screws *e*, or in any other suitable manner. D D represent two valves of equal size, arranged with the inner chamber B, so as to close against the seats *b b* thereof, and attached to a stem, *d*, which is secured to the flexible head C. E represents the tube through which the gas enters the device under the initial pressure. The influx pipe E leads directly to the inner chamber B between the valves D D, while the escape-pipe F connects with the outer chamber A. The chamber B, into which the gas is discharged from the influx-pipe E, permits the gas to expand before it

acts upon the valves, thereby avoiding any sudden and excessive pressure upon the valves and elastic diaphragm by the sudden generation of a large quantity of gas, and rendering the device more steady and uniform in its operation. The pressure upon the two valves being equal, and acting in opposite directions, a perfect equilibrium is obtained, and the opening and closing of the valves controlled solely by the pressure upon the elastic diaphragm C. The tension of the latter is so regulated that the valves D D will be held in an open position, when the pressure desired to be carried in the outflow-pipe is attained, so that when the pressure therein increases from any cause the flexible diaphragm will be raised, and the valves D D correspondingly closed until the gas-tension in the outflow-pipe is reduced to the pressure desired to be maintained.

My improved automatic valve is very simple in construction, and reliable and steady in its operation, and can be produced at comparatively small expense.

I claim as my invention—

The combination, with the outer chamber A, influx-pipe E, and escape-pipe F, of the inner chamber B, with which the pipe E communicates, of enlarged size, the said chamber provided with valve-seats *b b*, and balanced valves D D, connected with an elastic diaphragm, C, all arranged together as described, so that the gas passing through the influx-pipe will have an opportunity to expand in the enlarged chamber B, before acting upon the valves, thereby avoiding any sudden and excessive pressure upon the valves and diaphragm, as hereinbefore set forth.

A. KAYSER.

Witnesses:

EDWARD WILHELM,
CHAS. J. BUCHHEIT.