

A. O. KITTRIDGE.
SHEET METAL DOORS.

No. 183,941.

Patented Oct. 31, 1876.

Fig 1.

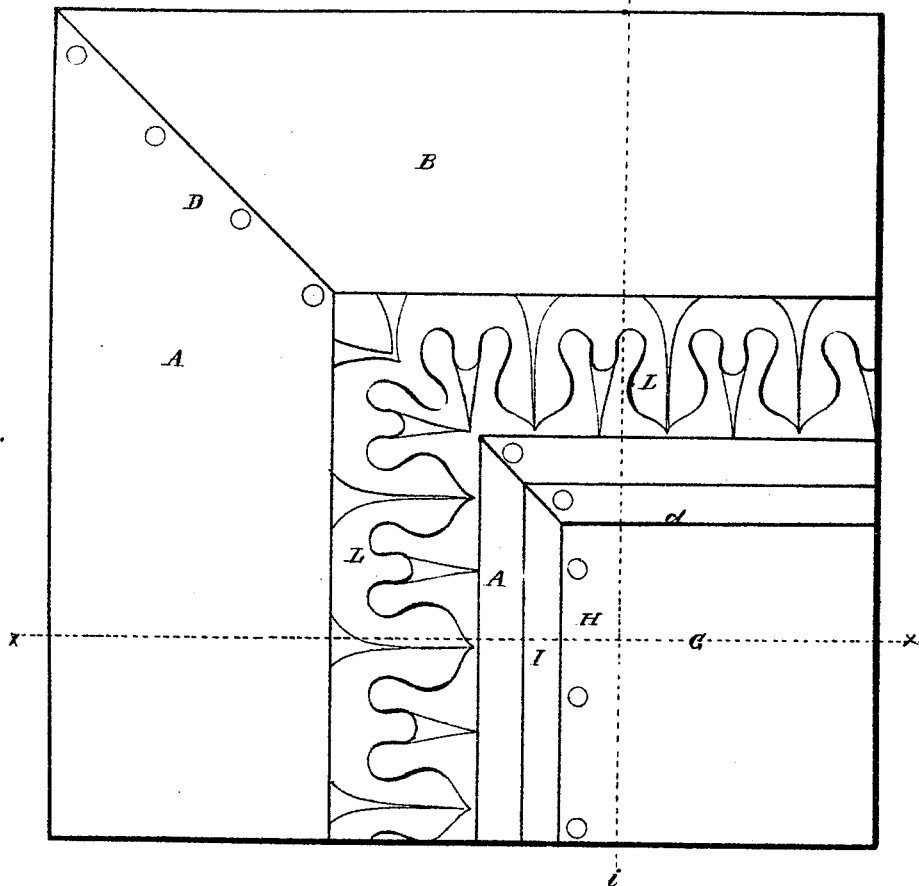
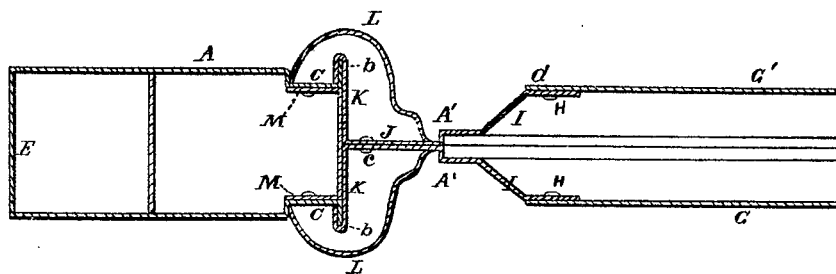

Fig. 2.



Witnesses.
J. S. Burrige
Wm. C. Mills

Inventor.
Anson O. Kittredge
Per Burrige & Co.
Attys.

A. O. KITTREDGE.
SHEET METAL DOORS.

No. 183,941.

Patented Oct. 31, 1876.

Fig. 3.

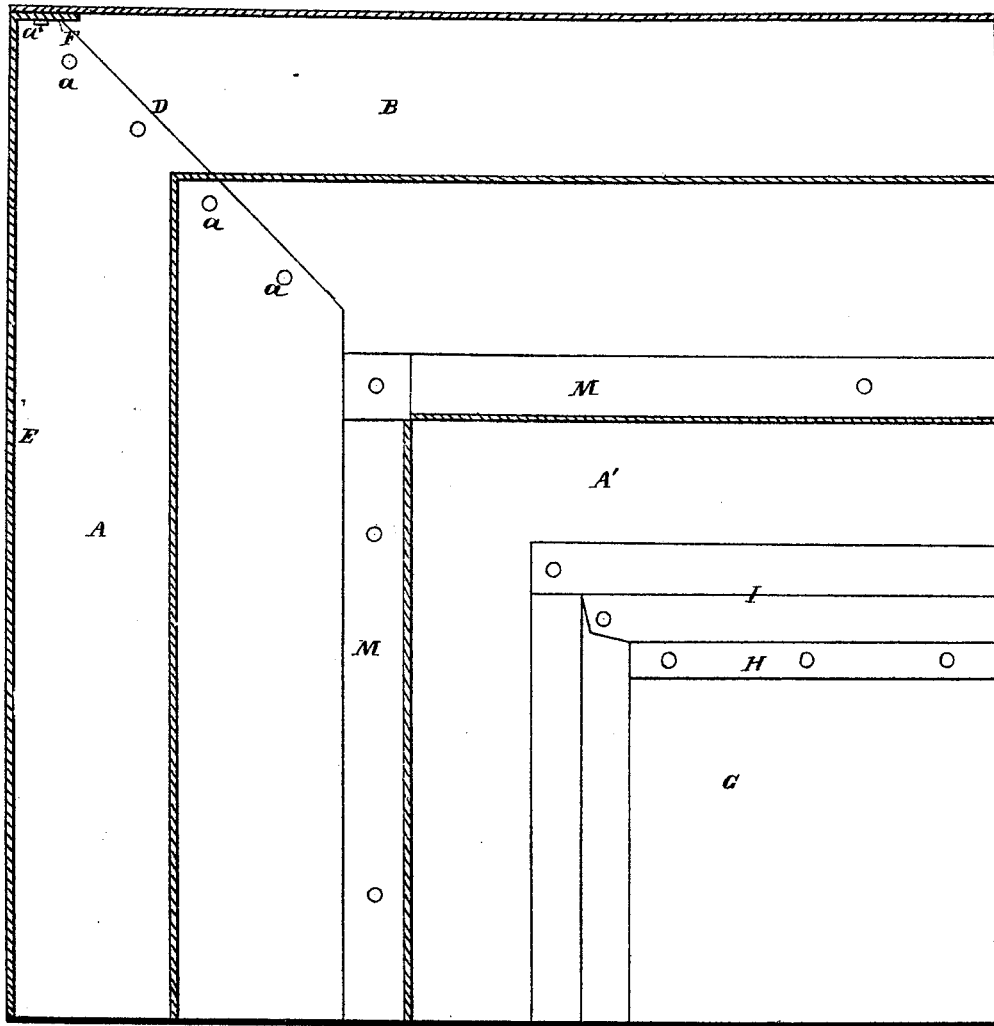
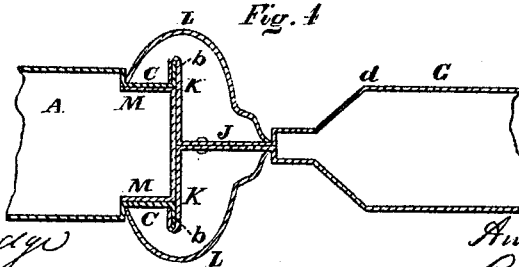

Fig. 4



Witnesses.

J. H. Burridge
Thomas E. Wells

Inventor.

Auson O. Kittredge
Per Burridge & Co.
Attys

UNITED STATES PATENT OFFICE

ANSON O. KITTREDGE, OF SALEM, OHIO, ASSIGNOR TO KITTREDGE CORNICE
AND ORNAMENT COMPANY, OF SAME PLACE.

IMPROVEMENT IN SHEET-METAL DOORS.

Specification forming part of Letters Patent No. 183,941, dated October 31, 1876; application filed
April 15, 1876.

To all whom it may concern:

Be it known that I, ANSON O. KITTREDGE, of Salem, in the county of Columbiana and State of Ohio, have invented a certain new and Improved Sheet-Metal Door; and I do hereby declare that the following is a full, clear, and complete description thereof, reference being had to the accompanying drawings, making part of the same.

Figure 1 is a corner section of a sheet-metal door. Fig. 2 is a transverse section. Fig. 3 is a vertical section. Fig. 4 is a section of Fig. 1 in direction of the line *i i*.

Like letters of reference refer to like parts in the several views.

This invention consists of a door made up of sheets of metal strengthened and supported by braces and plates, whereby is produced a strong, durable, and fire-proof door, that will neither warp nor shrink, and be much lighter than a wooden door of the same size.

The construction of the abovesaid door is as follows: The frame of the door consists of metal A B, Fig. 1, of which A represents the side or upright part of the frame, and B the ends or rails. A single sheet comprises one side of the frame, it being so bent as to form the edge and both sides or planes of the door-frame, as will be seen in Fig. 2, which represents the thickness and width of the side. Both sides and ends of the frame are made in the same way. It will be seen in said Fig. 2 that the inner edge of the side of the frame is narrowed in, forming a rabbet along each edge of the side, as will be seen at *c* in said Fig. 2. The edge of each rabbet is turned outward, forming a flange, *b*. The ends or rails are made in the same manner. The ends of the sides and rails of the frame are mitered together to form a corner of the door, as seen at D, Fig. 3, in which it will be seen that the end of the rail B laps over onto the end of the side A, and the two sections secured by rivets *a*. The edge E of the side A is continued beyond the sides, forming a tongue, F, which is bent at the angle of the corner, so as to fit under the edge of the rail, and thereto is secured by rivets *a'*. All the corners of the frame are made in like manner.

The panel or panels of the door consist of

two sheets of metal, G G', the edges of which are riveted at H, respectively, to fillets I, Fig. 2. Said fillets form on each side of the door a depression, A', along the top and bottom of the panels; or it may be along the sides of the panels in the event the fillets are used at the sides instead of at the top and bottom thereof. Either of the sides of the door-frame may be regarded as the top and bottom, so far as the union of the several sections of the door may be considered. The fillets alluded to are bent into the peculiar shape shown in the profile Fig. 2, in which it will be seen that they come together at J, and are secured by rivets *c*, forming at that place a double thickness of metal. Near the rivets *c* the fillets are deflected at right angles, forming a flange, K, the extreme edges whereof are turned back and over upon itself, making a return bend or lock, under which is received the flanges *b* of the sides of the door-frame. The return is rolled down hard upon the flanges, thereby clamping them tightly to the fillets, respectively, as will be seen in the profile view, Fig. 2—a transverse section of Fig. 1 in the direction of the line *x x*. Two opposite sides of the sheets composing the panel are in this way attached and secured to the door-frame, whereas the two other opposite sides are secured to the door-frame as follows: Instead of the fillets above described being used in making this connection of the panel to the door-frame, the material of the panel itself is extended so far as to make up the distance intervening between the raised part *d* of the panel and the frame. Said extended part of the panel is shaped exactly like the fillets, as will be seen in Fig. 4, which represents a profile view of the edge of the door, or a vertical section thereof, in direction of the line *i i*, Fig. 1.

In Fig. 4 it will be seen that the extended parts of the two panels come together at J, and which are also deflected at right angles, forming flanges K, the edges of which are turned back over upon itself, forming a lock wherein to receive the flanges *b* of the sides of the door-frame, substantially as described of the fillets, as will be seen in said Fig. 4. L is an ornamental trimming or molding covering the parts J, K, and C. One edge of the molding

is soldered to the frame A, and the other to the panel. Said molding not only ornaments the door, but it also serves as a brace to strengthen the union of the panel with the frame, thereby rendering the door stronger in its whole structure.

The connection of the panel with the frame is further strengthened with a channel-iron, M, made of sheet metal and riveted to the sides of the frame A, the relative position of which to the panel and frame will be readily seen in the drawings 3 and 4.

A door constructed as above described combines strength with lightness and durability, will not warp and shrink, as will doors made of wood, and may be painted and grained in

imitation of choice wood, making a superior and beautiful door.

What I claim as my invention, and desire to secure by Letters Patent, is—

As a new article of manufacture, a sheet-metal door herein described, consisting of the frame A, panels G G', fillets I, channel-iron M, and molding L, in the manner substantially as set forth, and for the purpose specified.

ANSON O. KITTREDGE.

Witnesses:

LUCIEN L. GILBERT,
JOHN T. WATERS.