

J. A. LAWSON.  
HEATING-STOVE.

No. 183,946.

Patented Oct. 31, 1876.

Fig. 1.

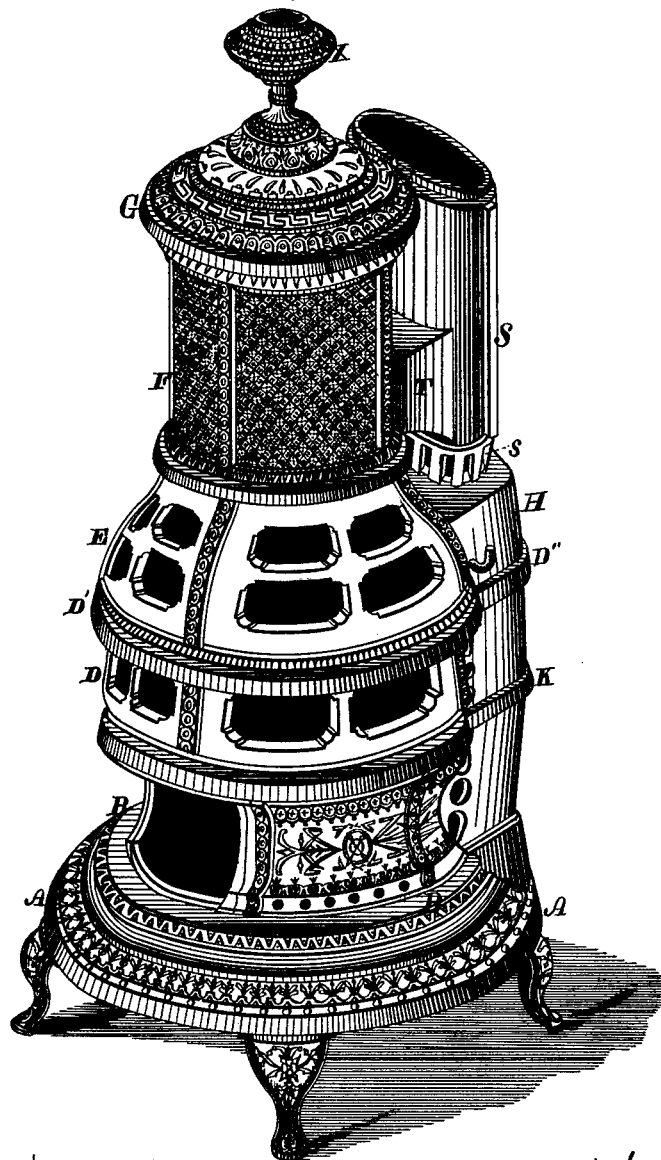

WITNESSES  
*Just C. Hutchinson*  
*John R. Young*

INVENTOR  
*J. A. Lawson, by*  
*Grindle and Co. his attys*

J. A. LAWSON.  
HEATING-STOVE.

No. 183,946.

Patented Oct. 31, 1876.

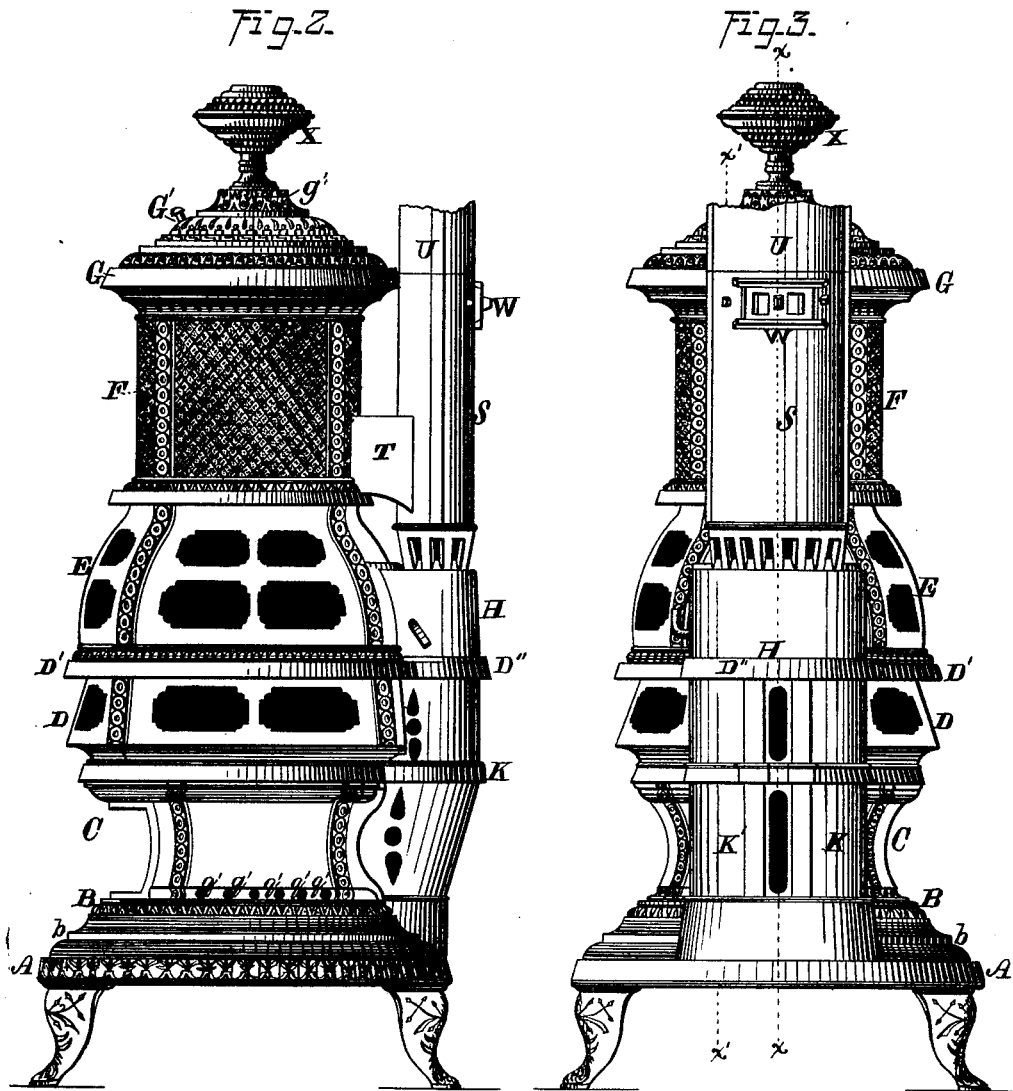

WITNESSES:  
 *Jas. L. Hutchinson*  
 *John R. Young*

INVENTOR:  
 *J. A. Lawson, by*  
 *Prindle and Co., his Attys*

J. A. LAWSON.  
HEATING-STOVE.

No. 183,946.

Patented Oct. 31, 1876.

Fig. 4.

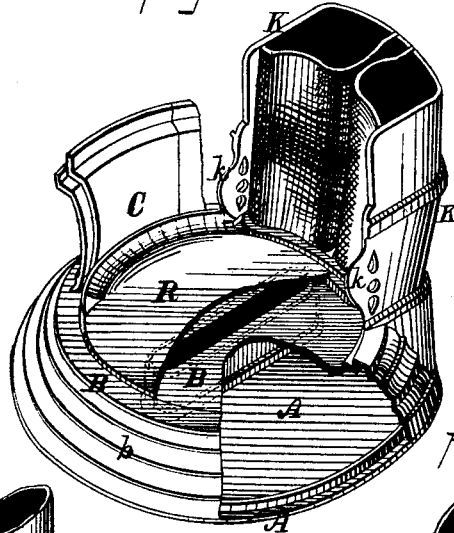

Fig. 5.

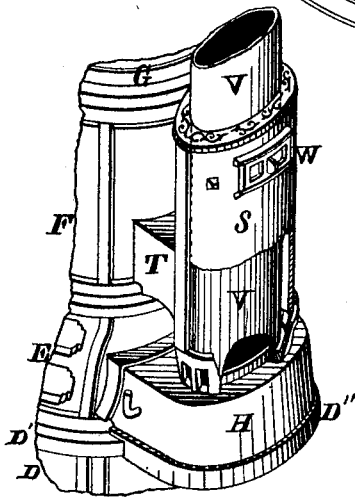
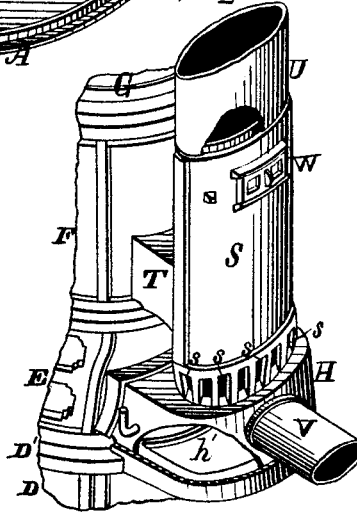

Fig. 6.



WITNESSES-  
 *Jas. C. Hutchinson.*  
 *John R. Young*

INVENTOR-  
 *J. A. Lawson, by*  
 *Prindle & Co., his attys.*

J. A. LAWSON.  
HEATING-STOVE.

No. 183,946.

Patented Oct. 31, 1876.

Fig. 7.

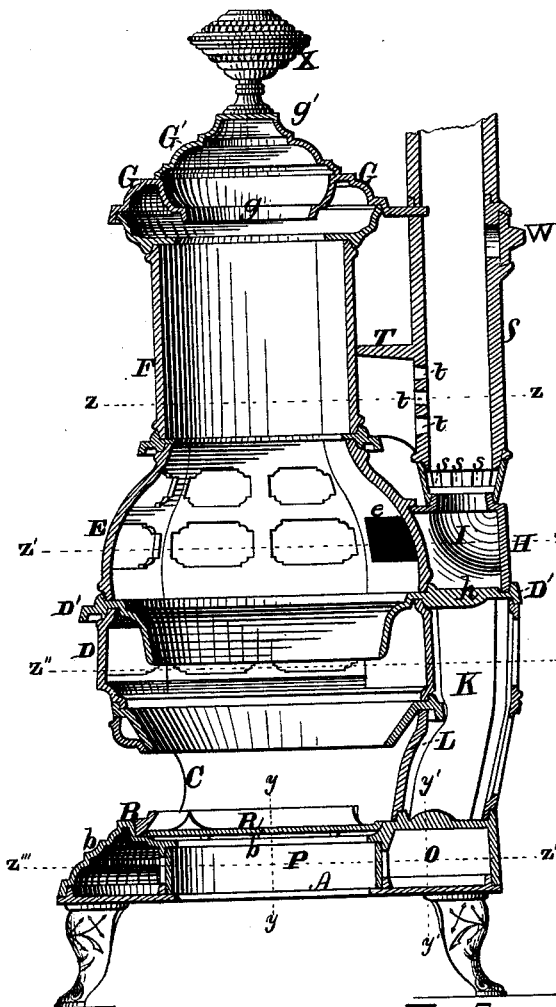

Fig. 8.

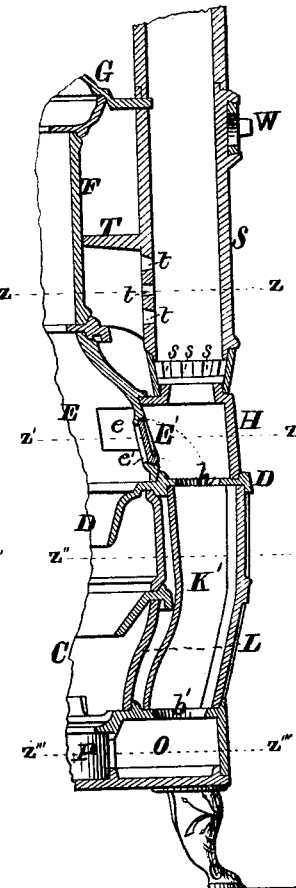

Fig. 9.

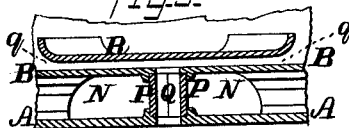
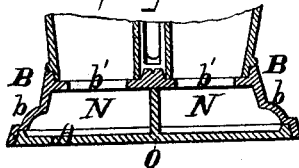

Fig. 10.



WITNESSES  
*Gas. E. Hutchinson.*  
*John R. Young*

INVENTOR.  
*J. A. Lawson, by*  
*Prindle & Co. his attys*

J. A. LAWSON.  
HEATING-STOVE.

No. 183,946.

Patented Oct. 31, 1876.

Fig. 13.

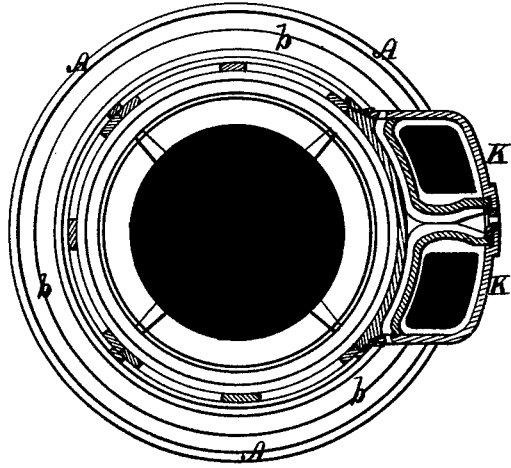

Fig. 12.

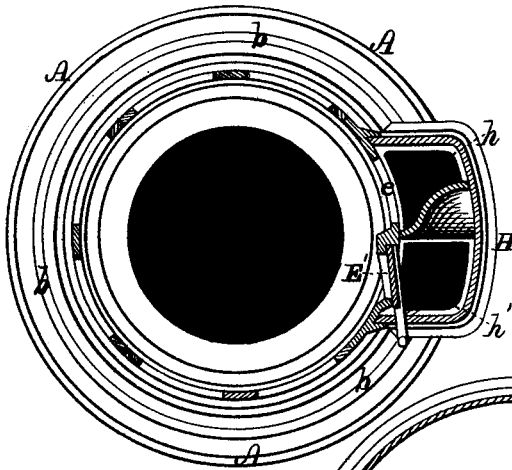

Fig. 11.

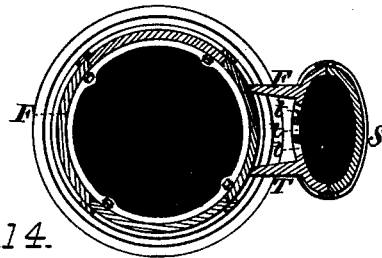
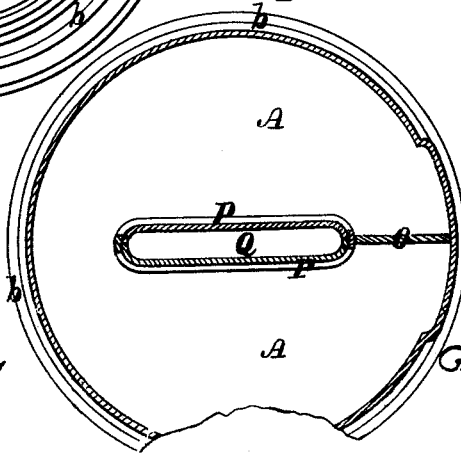

Fig. 14.



WITNESSES=

*Just. Hutchinson.*  
*John R. Young*

INVENTOR.

*J. A. Lawson, by*  
*Grindle & Co., his*  
*attorneys*

# UNITED STATES PATENT OFFICE.

JAMES A. LAWSON, OF TROY, NEW YORK.

## IMPROVEMENT IN HEATING-STOVES.

Specification forming part of Letters Patent No. 183,946, dated October 31, 1876; application filed June 7, 1876

*To all whom it may concern:*

Be it known that I, JAMES A. LAWSON, of Troy, in the county of Rensselaer and in the State of New York, have invented certain new and useful Improvements in Heating-Stoves; and do hereby declare that the following is a full, clear, and exact description thereof, reference being had to the accompanying drawings, making a part of this specification, in which—

Figure 1 is a perspective view of my improved stove. Figs. 2 and 3 are, respectively, a side and a rear elevation of the same. Fig. 4 is a perspective view of the base of said stove, a portion of the plates being removed so as to show the interior arrangement of flues. Figs. 5 and 6 are like views of the rear upper portion of the stove, and show different arrangements of the hot-air and smoke flues. Figs. 7 and 8 are vertical sections upon lines  $xx$  and  $x'x'$ , respectively, of Fig. 3. Figs. 9 and 10 are like views of the base upon lines  $yy$  and  $y'y'$ , respectively, of Fig. 7; and Figs. 11, 12, 13, and 14 are horizontal sections upon lines  $zz$ ,  $z'z'$ ,  $z''z''$ , and  $z'''z'''$ , respectively, of Figs. 7 and 8.

Letters of like name and kind refer to like parts in each of the figures.

The design of my invention is to increase the efficiency and capacity of stoves employed for heating rooms by radiation; and to this end it consists, principally, in a heating-stove provided with a base-flue, which communicates at its rear ends with the descending and ascending flues, and, encircling a hollow flue-strip that forms a passage for the external air, follows a continuous circular line, which has at all points one horizontal plane, substantially as and for the purpose hereinafter specified. It consists, further, in a heating-stove provided with an air-space, which is located between the base-flue and ash-pit, communicates laterally with the external air, and, by means of a central vertical flue, with the space beneath the stove, whereby air is permitted to pass upward against the bottom of said ash-pit, and thence directly outward and upward, substantially as and for the purpose hereinafter shown. It consists, further, in a descending and an ascending flue, constructed as shown, arranged side by side, and disconnected from each other, and from the stove, except where their ends are connected to or

with the base, and with the chamber from which the exit-flue passes upward, substantially as and for the purpose hereinafter shown and described. It consists, further, in the means employed for connecting the upper ends of the descending and ascending flues with the body of the stove, substantially as and for the purpose hereinafter specified. It consists, further, in the means employed for inclosing the space between the outer side of each rear flue and the body of the stove, substantially as hereinafter shown. It consists, further, in the combination of the descending and ascending flues with the circular suspended base-flue, substantially as and for the purpose hereinafter set forth. It consists, further, in a magazine-stove, in which the opening for supplying fuel to the magazine is inclosed by means of the front upper portion of the casing, which is pivoted upon and rotates around the base of the urn, substantially as and for the purpose hereinafter shown and described. It consists, further, in the combination of the fixed and movable portions of the upper end of the casing and the urn attached to the former, substantially as and for the purpose hereinafter specified. It consists, further, in the construction of the fixed and movable portions of the upper end of the casing of the stove, by means of which flanges and beads other than those employed in the general finish are avoided, substantially as and for the purpose hereinafter shown. It consists, further, in the peculiar construction of the detachable hot-air flue for the rear portion of the stove, substantially as and for the purpose hereinafter set forth. It consists, further, in the combination of the detachable hot-air flue with a box or chamber, which extends between the same and the rear side of the casing of the stove, and is open at its lower side, substantially as and for the purpose hereinafter shown and described.

In the annexed drawings, A represents the bottom plate, and B the top plate, of the base of my stove, which bottom plate has a general circular form in plan view, and horizontally has a flat shape, while said top plate B corresponds in size and shape in plan view, and is fitted at its edge to the edge of the latter, but has a molded edge,  $b$ , that raises its central portion considerably above the upper surface of said plate A, and leaves between

said plates a space, from which the bottom flues are formed, as is hereinafter described. From the central portion of the plate B the casing C of the ash-pit section extends upward and slightly outward. Above the latter is placed the fire-pot-section casing D, which has, preferably, vertical walls. Above said casing D is placed the upward and inward curving casing E of the combustion-chamber, from which the magazine-section F extends vertically upward, and at its upper end is surmounted by a top plate, G, said parts being constructed and mounted in the usual manner.

The casing of the ash-pit, fuel-chamber, and combustion-chamber are formed upon circular lines, and the two last-named parts are provided upon their sides and fronts with mica openings, but at their rear side said ash-pit section C and fire-pot section D are made close, while said combustion-chamber section E is at such point provided with two openings, *e* and *e'*, through which the heated escaping products of combustion pass to the rear flues. Secured upon the rear side of the combustion-chamber section E is a chamber, H, which has the exterior form shown in Figs. 5 and 6, is open at its lower side, and incloses the openings *e* and *e'*.

The lower side of the chamber H is divided by means of a cross-bar, *h*, into two openings, *h'* and *h''*, while a flue-strip, I, is mounted upon the upper side of said cross-bar, extends from front to rear between the rear walls of said chamber and the casing E, and vertically extends upward and to one side, so as to inclose the opening *e*, and prevent heated gases from the latter from passing in any other than a downward direction. From each opening *h'* and *h''* a pipe, K, extends downward to the rear portion of the base, and at its lower end opens into an opening, *b'*, that is provided within the plate B. The back pipes K and K' and chamber H are secured in place at their point of contact by means of a ring, D', which is interposed between the casing-sections D and E, and at its rear end has a projection, D'', which passes between said chamber and pipes, and is provided with recesses into which the edges of said parts are mounted. As seen in Figs. 4 and 9, the rear walls of the pipes K and K' are formed upon a line which is concentric with the axial center of the stove. The outer walls of said pipes are formed upon parallel lines, while their inner and front walls are separated from each other and from the rear side of the stove by an air-space, L. At each of its sides the space L is inclosed by means of a wing, *k*, which is formed upon the pipe K; extends forward against the casing of the stove, and is provided with openings through which air may enter said space, while the rear portion of the latter is inclosed by an open-work plate, M, that extends between the pipes K and K'. The space N, within the base, forms a flue, which at its central and rear portions is divided by the following-described means, so as

to cause said flue to furnish communication between the lower ends of the pipes or flues K and K': At the rear side, at the transverse center of the flues N, a flue-strip, O, extends vertically between the plates A and B, and from the rear side of flue forward about one-half the distance to the axial center of the base. From the front end of the flue-strip O two vertical flue-strips, P and P, extend forward in the same line to an equal distance in front of the axial center of the base, and vertically between the plates A and B. The strips P and P are separated, except at their ends, which are curved inward and united together, and inclose a space, Q, that, by means of corresponding openings *a* and *b'*, provided in the plates A and B, respectively, forms a flue which communicates at its lower end with the space beneath the stove, and at its upper end with the space above said plate B. This arrangement forms of the space within the base a flue that has a general U shape, and as its rear ends communicate with the flues K and K' it will be seen that the heated gases from the fuel-chamber passing down the former will pass forward within said flue N to and around the front ends of the flue-strips P and P; from thence rearward into and through the flue K', and from the latter into the exit-flue, as will be hereinafter described.

The opening *e'* is inclosed, when desired, by means of a damper, E', and when so inclosed the heated gases from the combustion-chamber are caused to pass rearward through the opening *e*, downward through the flue K, forward and then rearward through the suspended flue N, and from thence upward through the flue K' to the exit-flue.

The heat of the gases surrounding the flue Q will cause the air contained therein to become heated, and in order that such heated air may be utilized for the purpose of warming the room in which the stove is placed the following-described construction is employed: The central portion of the plate B is slightly depressed, and above such depressed portion is fitted a plate, R, which closely incloses the upper side of the same, and forms the bottom of the ash-pit. From each side of the space *q*, between the plates B and R, suitable openings *q'* and *q'* are provided for the escape of air, which openings extend laterally outward through the lower portion of the contiguous plates of the ash-pit casing C. This arrangement causes a rapid circulation of air through the flues or passages Q and *q*, which air, being brought into contact with the heated plates of the interior of the base, receives and transmits to the room a large percentage of heat which would otherwise be wasted.

The circulation of air through the space L, between the flues K and K' and the casing of the stove, also furnishes means for utilizing heat that would otherwise be lost, and serves to prevent said flues and casing from becoming unduly heated at such points.

Upon the rear side of the stove is placed a

pipe, S, which is supported at its lower end upon or by means of the chamber H, and from thence extending vertically upward, has its upper end at its forward side attached to or upon the rear edge of the top plate G, for the purpose of insuring its position. Upon the front side of said pipe is secured a box or hood, T, which extends between the same and the casing F of the magazine-section, is open at its front and lower sides, and incloses a space that communicates through a series of openings, *t* and *t*, with the interior of said pipe. The lower end of the pipe S is provided with a series of openings, *s*, *s*, and *s*, through which and through the openings *t* and *t* air from without may pass into its interior.

The object of the pipe S is to enable air to be heated and conveyed to an upper room, for which purpose a pipe, U, (shown in Fig. 6,) is placed upon its upper end, and extended upward through the floor, when it will be found that a strong current of air, heated by contact with the rear central portion of the stove, will pass through said pipe.

If desired, the exit-flue V may pass from the upper side of the chamber H upward through the center of the pipe S, as seen in Fig. 5, so as thereby to increase the heat within the latter; or said exit-flue may pass rearward from said chamber, as shown in Fig. 6.

When not needed for heating another room, the upper end of the pipe S may be inclosed by a cap, in which openings are provided for the outward passage of heated air. A register or damper, W, placed upon the rear side, near the upper end of the pipe S, enables a proportion of the air heated therein to be caused to pass outward when not required for use in the upper room.

The top plate G has a dome-shaped central portion directly over the magazine, one-half of which is removed, so as to leave an opening, *g*, (seen in Figs. 2 and 7,) through which fuel may be supplied to said magazine. To the opening *g* is fitted a cover, G', which exactly fills the same and completes the finish of the plate G, so that when said cover is closed said plate presents an appearance of solidity. At the center of the plate G is provided an urn, X, which is secured in place, and at its lower end or neck furnishes a bearing for a ring, *g'*, that encircles the same, and forms part of the cover G'.

As thus arranged the cover G' is pivoted to, and may be caused to rotate around, the urn-neck, so as to close or open the feed-opening *g*, said urn not only performing the office of a pivotal bearing for said cover, but also operating to prevent displacement of the latter.

To move the cover G' away from its opening it is only necessary that said cover should be raised vertically until its edge will pass laterally over the upper surface of the plate G, which latter receives and supports the weight of said cover.

By this construction no lateral space is re-

quired for the swinging of the cover, and, as no strain is thrown upon its pivotal bearing, nothing less than actual violence can cause it to become broken or displaced.

If desired, the cover G' may be hinged or pivoted at one corner, so as to swing to one side of the stove instead of revolving around the base of the urn.

Having thus fully set forth the nature and merits of my invention, what I claim as new is—

1. A heating-stove provided with a base-flue, which communicates at its rear ends with the descending and ascending flues, and, encircling a hollow flue-strip that forms a passage for the external air, follows a continuous circular line, which has at all points one horizontal plane, substantially as and for the purpose specified.

2. A heating-stove provided with an air-space, which is located between the base-flue and ash-pit, communicates laterally with the external air, and, by means of a central vertical flue, with the space beneath the stove, whereby air is permitted to pass upward against the bottom of said ash-pit, and thence directly outward and upward, substantially as and for the purpose shown.

3. The descending and ascending flues K and K', respectively constructed as shown, arranged side by side, and disconnected from each other and from the stove, except at their ends, substantially as and for the purpose set forth.

4. The means employed for connecting the upper ends of the descending and ascending flues with each other and with the stove, consisting of the ring D', fitted between the casing-sections D and E, and provided with a rearward offset, D'', that embraces the ends of said flues, substantially as shown and described.

5. The means employed for inclosing the space L between the flues K and K' and the casing of the stove, consisting of the wings *k* and *k'*, formed upon said flues, and the plate M, placed between their inner rear corners, said parts being provided with openings for the passage of air, substantially as and for the purpose specified.

6. The combination of the descending and ascending flues K and K', respectively, with the suspended base-flue N, substantially as and for the purpose shown.

7. A magazine-stove in which the opening for supplying fuel to the magazine is inclosed by means of the upper front portion of the casing, which is pivoted upon and rotates around the base of the urn, substantially as and for the purpose set forth.

8. The combination of the fixed portion of the top plate G, movable portion or cover G', and urn X, secured to the former and forming an axial bearing for the latter, substantially as and for the purpose shown and described.

9. The top plate G, having an opening, *g*, formed by the removal of a section of its front



upper side, the urn X, secured to the axial center of said plate, and the cover G', fitted to said opening, and provided with a ring, g', which encircles the base of said urn, said parts being combined to operate substantially as and for the purpose specified.

10. In combination with the top plate G, provided with the opening g, the cover G', fitted within said opening, and having its upper surface flush with the upper surface of said plate, and provided at its axial center with a ring, g', that forms the apex or center of the dome-shaped central portion of the same, substantially as and for the purpose shown.

11. In combination with the rear portion of the stove, the detachable pipe S, having its lower end secured upon the chamber H, and provided with openings s, s, and s, and its upper end arranged to receive a pipe, and se-

cured to or upon the casing of said stove, substantially as and for the purpose set forth.

12. In combination with the hot-air pipe S, constructed as shown, and secured to or upon the rear side of the stove, the box or hood T, attached to the front side of said pipe, extending between the same and the casing of the stove, and communicating with the interior of said pipe by means of the openings t and t, substantially as and for the purpose shown and described.

In testimony that I claim the foregoing I have hereunto set my hand this 26th day of April, 1876.

JAMES A. LAWSON.

Witnesses:

CHAS. H. ADAMS,  
FRANK B. MARX.