

G. VOLL.

FASTENERS FOR MEETING-RAILS OF SASHES.

No. 183,992.

Patented Oct. 31, 1876.

FIG. 1.

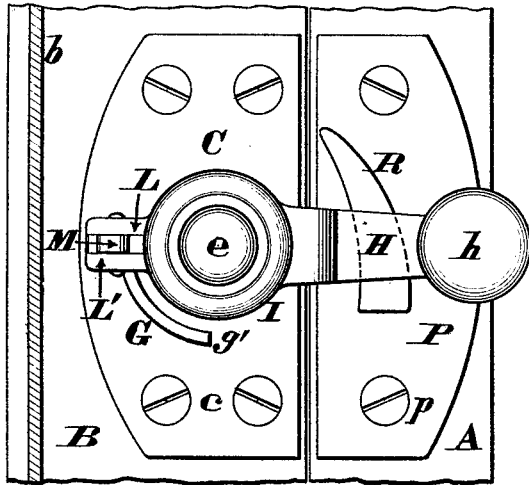

FIG. 3.

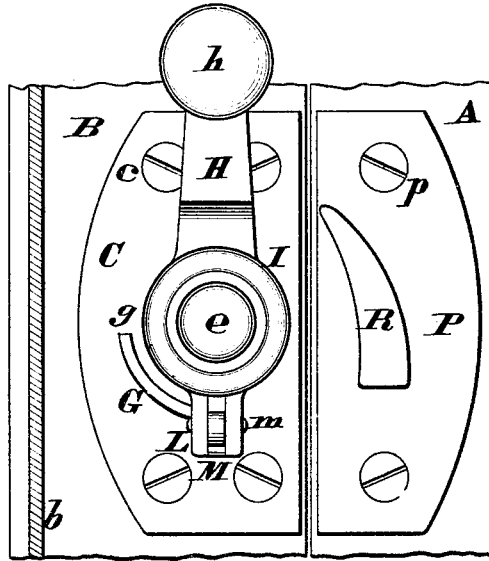

FIG. 2.

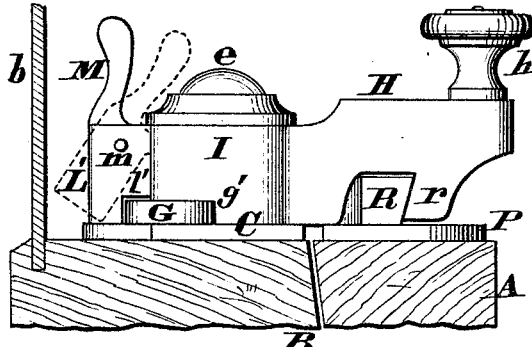

FIG. 4.

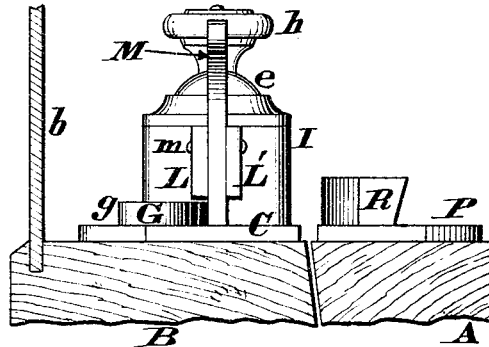

FIG. 5.

FIG. 9.

FIG. 7.

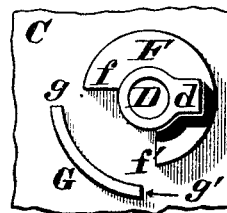
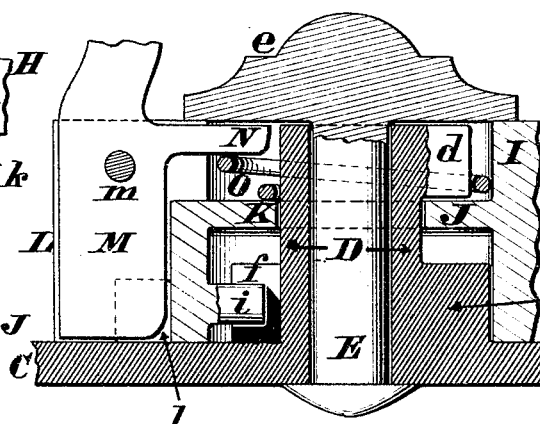
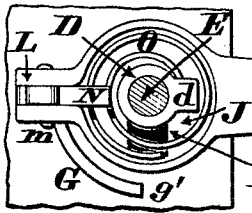
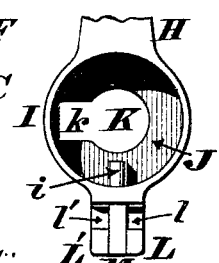
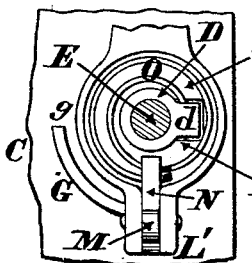

FIG. 6.

FIG. 8.



Attest.
Edward
S. de. White.

George Voll,
by Jas. H. Layman
his Attorney.

UNITED STATES PATENT OFFICE

GEORGE VOLL, OF CINCINNATI, OHIO.

IMPROVEMENT IN FASTENERS FOR MEETING-RAILS OF SASHES.

Specification forming part of Letters Patent No. **183,992**, dated October 31, 1876; application filed August 28, 1876.

To all whom it may concern :

Be it known that I, GEORGE VOLL, of Cincinnati, Hamilton county, Ohio, have invented certain new and useful Improvements in Fasteners for the Meeting-Rails of Window-Sashes, of which the following is a specification :

The object of this invention is to provide a cheap, simple, and durable device wherewith the meeting-rails of a pair of window-sashes may be so securely fastened together as to prevent them being unlocked from the outside, while at the same time the sashes can be readily disengaged by any person within the room; and my fastener consists, essentially, of a plate capable of being secured to the meeting-rail of the upper sash, said plate being provided with an upwardly-projecting tube, which serves as the pivot or center of vibration of a horizontally-oscillating lever, having a spur near its front end that engages with the customary under cut and eccentric flange or rib of the plate that is attached to the lower sash-rail. The rear end of this lever has pivoted to it a latch that is maintained in its normal or closed condition by a suitable spring, and when thus closed the lower portion of said latch bears against one end of a curved flange in such a manner as to effectually prevent the locking-lever being shifted up between the two meeting-rails. The aforesaid curved flange occupies about one-fourth of a circle, and is concentric with the tubular pivot of the lever, being cast with or otherwise rigidly secured to the same plate as is said tubular pivot. Now, by simply pressing one finger against the upwardly-projecting end of the spring-latch the lower end thereof springs outwardly, and is at once thrown out of contact with the extremity of the eccentric flange. This act leaves the lever free to be turned on its pivot, and as soon as said lever has described about one-fourth of a circle the stress of the spring forces the lower portion of the pivoted latch inwardly, so as to come in contact with the other extremity of the concentric flange, and thereby lock the lever in its new position.

The tubular pivot previously alluded to occupies a central or axial position within the

barrel or cylindrical portion of the locking-lever, and said cylinder is provided with a horizontal partition, upon which rests a volute spring. This spring serves the twofold purpose of maintaining the pivoted latch in its normal position, and also of keeping the operative parts snugly together so as to prevent rattling. Projecting laterally from the tube is a lug or pin that rests upon the upper surface of the horizontal partition of the cylinder, by which arrangement said lug coacts with the axial bolt or rivet in securing the lever to its appropriate plate. This laterally-projecting lug passes through a suitable slot in said partition when the fastener is first fitted together.

In the annexed drawings, making part of this specification, Figure 1 is a plan of my fastener in its normal or locked position, and Fig. 2 is an elevation of the same. Fig. 3 is a plan showing the fastener unlocked, and Fig. 4 is an elevation of the same. Fig. 5 is a plan showing the operative parts in the same position as represented in Fig. 1, the cap being removed, and the rivet sectioned. Fig. 6 is a similar view of the same devices, but showing the locking-lever in the position represented in Fig. 3. Fig. 7 is a plan of a portion of the plate which is secured to the upper sash-rail. Fig. 8 is a plan of a portion of the locking-lever; and Fig. 9 is an enlarged vertical section through the operative parts of the fastener.

A represents the meeting-rail of the lower sash, and B the corresponding rail of the upper sash, which latter rail is provided with a light, *b*. Secured to rail B with screws *c* is a horizontal plate, C, having a tube, D, cast with it, or otherwise attached thereto. This tube is traversed with a rivet, E, whose head *e* imparts a finished appearance to the lock, and at the same time said head acts as a cap to conceal a spiral or volute spring, which serves the twofold purpose of maintaining the latch in its normal position, and of holding the locking-lever snugly against plate C. Furthermore, said plate is furnished with a segmental hub or boss, F, whose terminations or shoulders *f f'* serve as stops to limit the motion of the locking-lever H in either direction

as will presently appear. Projecting from said plate is a flange or rib, G, concentric with rivet E, and occupying somewhat less than a quadrant. The terminations *g* and *g'* of this flange act as stops for the retaining-latch of the fastener.

The locking-lever previously alluded to consists of an arm, H, whose inner end is furnished with any convenient knob or handle, *h*. This lever is provided with a cylindrical portion or barrel, I, having a horizontal partition, J, which latter is pierced with an eye, K, and a slot, *k*. This eye fits snugly around the tube D, while the slot *k* permits a lug, *d*, being passed up through said partition J when the lock is fitted together. The aforesaid lug *d* projects laterally from tube D. The bore of the lower portion of barrel I is of such diameter as to allow the lever H rotating freely in a horizontal plane around the hub F. By this arrangement said hub coacts with tube D to constitute a pivot or fulcrum for locking-lever H *h*. Barrel I has an inwardly-projecting stump or other stop, *i*, which is adapted to strike against either of the shoulders *f* or *f'*, according as the lever H is swung either to the right or left. Projecting rearwardly from this barrel are two vertical and parallel cheeks, L L', between which is fitted a latch, M, capable of swinging on pivot, *m*. These cheeks are cut away at their lower ends, as shown at *l l'*, in Fig. 8, so as to clear the eccentric rib G when lever H is turned on its pivot. These cheeks, instead of extending down as far as plate C, may stop short of flange G, in which case the notches *l l'* will be omitted, as seen in Fig. 4. Projecting from latch M toward the tube D is a toe, N, that sustains the upward stress of a volute spring, O. This spring is coiled around tube D, and rests upon the partition J, as more clearly shown in Figs. 5 and 6. The stress of this spring holds the barrel I down on plate C, and also keeps the toe N in contact with the under side of cap *e*. (See Fig. 9.)

This arrangement enables said spring, acting as an anti-rattler, to prevent any clattering of the fastener when the sashes are shaken by the wind or otherwise. Secured to meeting-rail A, with screws *p*, is a plate, P, having the customary eccentric flange K, with whose front and undercut edge the spur *r* of lever H engages, as seen in Fig. 2.

To fit my fastener together, it is only necessary to dispose lever H longitudinally of plate C, and allow the lug *d* of tube D to pass through slot *k* of partition J, after which spring O is applied in its proper position. Pivot E is then inserted in tube D and headed up at its lower end, thereby causing the cap *e* to serve as a cover for barrel I. The two plates P and C are then applied to the respective rails A and B in the usual manner. To lock these rails A and B together, lever H *h* is swung to the left until stump *i* impinges against shoulder *f* of hub F, and thus arrests the far-

ther movement of the lever in that direction. As the lever turns on its pivot D F the lower end of latch M rides around against the outer periphery of rib G; but, as soon as said latch is brought opposite the end *g* of said rib, the stress of spring O on the toe N swings the free end of the latch toward the barrel I. In this position of lever H it is evident the fastener cannot be unlocked by inserting any implement between the rails A and B, for the simple reason that any attempt to turn said lever to the right will be effectually resisted by the latch M bearing against the end *g* of rib G. It will also be noticed that in this position of the fastener the lug *d* rests upon the partition J, and thereby overcomes any attempt to drive the lever H up bodily from off its supporting-plate C. (See Figs. 5 and 9.) It will thus be seen that said lug *d* coacts with rivet E *e* to secure the lever H to its plate C. While thus effectually preventing the window being opened from the outside, any person within the room can unlock the fastener in a moment by the performance of the following simple manipulations: One finger is engaged over the upwardly-projecting end of latch M, and said latch is turned until its handle rests against cap *e*, as indicated by dotted lines in Fig. 2, the spring O readily yielding to allow this movement of the latch. This act throws the lower end of said latch out far enough to clear the rib G, and leaves lever H at liberty to be swung to the right, and be thereby disengaged from the eccentric flange R. As soon as the lever has described one-fourth of a circle the stump *i* comes in contact with the shoulder *f'* of hub F, and at once arrests any further movement of said lever to the right. Latch M now flies down behind the end *g'* of rib G, and secures the lever H in its new position; and, when thus secured, said lever cannot be accidentally shifted by any shaking of the window or otherwise. When the lever is in this position lug *d* is vertically above slot *k*, as seen in Fig. 6; but, as no upward strain can now be brought to bear against lever H, such disposition of the slot with reference to the lug is not objectionable, especially as rivet E *e* acts as a secondary device to maintain the barrel I on plate C.

While preferring to use the concealed volute-spring O, as described, I reserve the right to operate latch M with a spring applied externally to barrel I, or with a spring or elastic cushion located between the cheeks L L'.

I claim as my invention—

1. The lever H, pivoted to plate C of a sash-fastener, and carrying at its rear end a vertically-pivoted spring-latch, M N, which latter is capable of impinging against either end of concentric rib G *g g'* of plate C, for the purpose of locking said lever, substantially as here-in described.

2. The combination of supporting-plate C, tube D, rivet E *e*, shouldered hub F *f f'*, concentric flange G *g g'*, lever H I *i*, operating-

spring O, and pivoted latch M N, substantially as herein described.

3. The combination of tube D, partitioned cylinder H I J, eye K, slot *k*, and laterally-projecting lug *d*, when said slot and lug are arranged with reference to each other, substantially as herein described.

In testimony of which invention I hereunto set my hand.

GEORGE VOLL.

Witnesses:

JAMES H. LAYMAN,
L. H. BOND.